

GREEN POWER 90 NEGRA Cristal negro | 110.0389.179

FAMILY : Campanas | SERIES : DISPLAY | MODEL : GREEN POWER 90 NEGRA | FINISH : Cristal negro | INSTALLATION TYPE : T invertida

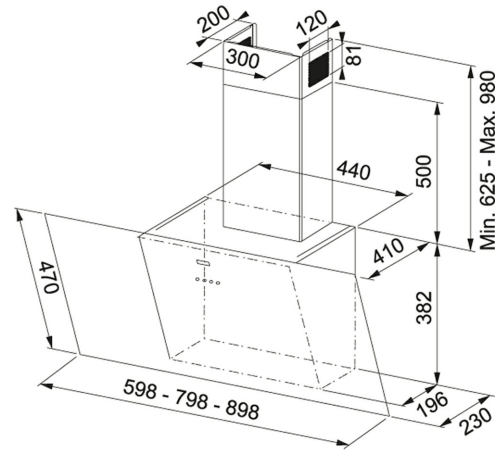

Campana decorativa de pared DISPLAY GREENPOWER en cristal negro de 90 cm.

DATOS TÉCNICOS

Potencia Máx. (W)	255-W
Total Power	257-W
Iluminación	LEDS 2x1W
Aspiración en Mín. (UNE EN-61591)	290 m3/h
Aspiración en Máx. (UNE EN-61591)	560 m3/h
Aspiración en Int. (UNE EN-61591)	690 m3/h
Pot. Sonora en Mín. (UNE EN-60704-3)	52 dB(A)
Pot. Sonora en Máx. (UNE EN-60704-3)	65 dB(A)
Pot. sonora en Int. (UNE EN-60704-3)	70 dB(A)
Tipo de Mandos	Touch
Ancho	90,00 cm
Tipo de campana	Decorativa
Clase Energética	A
Número de velocidades	3+int.
Salida	Ø-120---150-MM
Voltage	220-240V
Pressure	530,00 Pa
Grease filter	Filtros de Aluminio
Type of motor	Energy 800 Plus
Acabado	Negro
Dimensions	900X410