

70 ACERO Acero inox | 320.0528.012

FAMILY : **Campanas** | SERIES : **GAVIA** | MODEL : **70 ACERO** | FINISH : **Acero inox** | INSTALLATION TYPE : **T invertida**

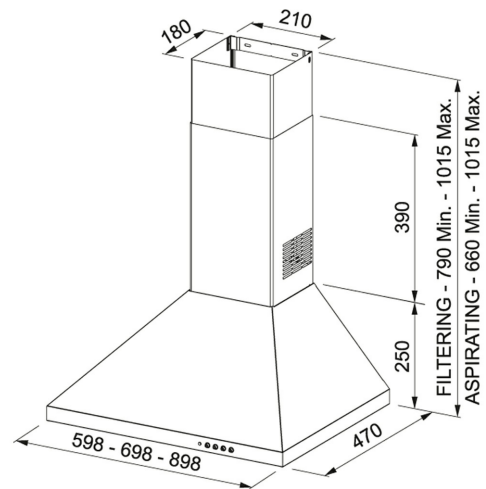

DATOS TÉCNICOS

Potencia Máx. (W)	250 W
Total Power	253 W
Iluminación	LEDS-2X1.5W
Aspiración en Mín. (UNE EN-61591)	320 m3/h
Aspiración en Máx. (UNE EN-61591)	650 m3/h
Aspiración en Int. (UNE EN-61591)	740-M3/H
Pot. Sonora en Mín. (UNE EN-60704-3)	53 dB(A)
Pot. Sonora en Máx. (UNE EN-60704-3)	68 dB(A)
Pot. sonora en Int. (UNE EN-60704-3)	71 dB(A)
Tipo de Mandos	Pulsantes
Ancho	70,00 cm
Tipo de campana	Isla
Clase Energética	B
Número de velocidades	3+int.
Salida	Ø-120---150-MM
Voltage	220-240V
Pressure	500,00 Pa
Grease filter	Filtros de Aluminio
Type of motor	Energy 900
Acabado	Acero Inoxidable
Dimensions	700X470