

SALORA

GEBRUIKERSHANDLEIDING

ICE12B

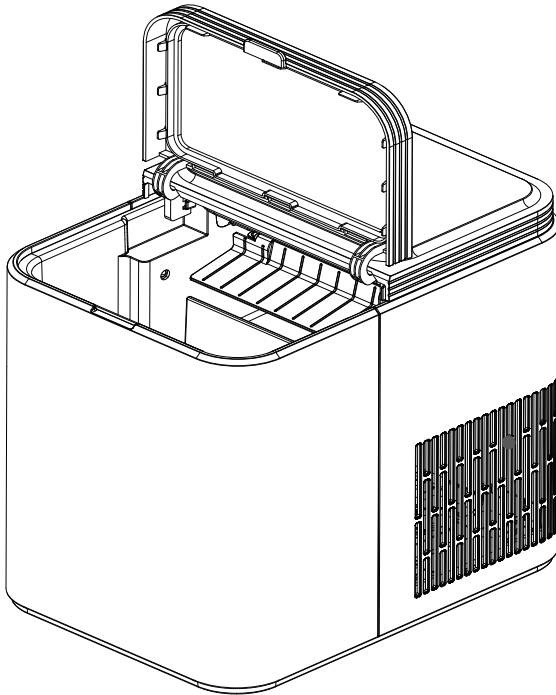

THANK YOU LETTER

Thank you for choosing SALORA! Before using your new SALORA product, please read this manual thoroughly to ensure that you know how to operate the features and functions that your new appliance offers in a safe way.

CONTENTS

THANK YOU LETTER	01
SAFETY INSTRUCTIONS	02
SPECIFICATIONS	05
PRODUCT OVERVIEW	06
OPERATION INSTRUCTIONS	07
CLEANING AND MAINTENANCE	10
TROUBLESHOOTING	12

SAFETY INSTRUCTIONS





Intended use

Before switching on the appliance for the first time read the following safety information!

This appliance is intended to be used in household and similar applications such as staff kitchen areas in shops, offices and other working environments; farm houses and by clients in hotels, motels and other residential type environments; bed and breakfast type environments; catering and similar non-retail applications.

If the appliance is used commercially please note that the manufacturer cannot accept any liability for any damage.

Explanation of symbols

	DANGER This symbol indicates that there are dangers to the life and health of persons due to extremely flammable gas.
	WARNING OF ELECTRICAL VOLTAGE This symbol indicates that there is a danger to life and health of persons due to voltage.
	WARNING The signal word indicates a hazard with a medium level of risk which, if not avoided, may result in death or serious injury.
	CAUTION The signal word indicates a hazard with a low degree of risk which, if not avoided, may result in minor or moderate injury.
	ATTENTION The signal word indicates important information (e.g. damage to property), but not danger.



WARNING

Risk of fire/Flammable materials

- **DANGER** Risk of fire or explosion. Flammable refrigerant used. Do not use mechanical devices to defrost refrigerator. Do not puncture refrigerant tubing.
- **DANGER** Risk of fire or explosion. Flammable refrigerant used. To be repaired only by trained service personnel. Use only manufacturer authorized service parts. Any repair equipment used must be designed for flammable refrigerants. Follow all manufacturer repair instructions. Do not puncture refrigerant tubing.



WARNING General safety

- Install in accordance with the manufacturer's instructions. The unit is for indoor household use only.
- This product should not be recessed or built-in an enclosed cabinet. It is designed for freestanding installation only. Ensure a minimum of three inches of clearance around the side and back walls of the unit for proper air circulation.
- Keep ventilation openings, in the product, clear of obstruction.
- Do not install or operate the machine in a sealed space, such as a closed room.

- Use the machine in a well-ventilated area with a temperature, between 50°F and 90°F.
- Do not install near any heat sources, such as radiators, heat registers, stoves, other cooking appliances or in direct sunlight.
- Do not store or use gasoline or any flammable liquids inside or in the vicinity of this appliance.
- Do not store explosive substances such as aerosol cans with a flammable propellant in this appliance.
- Do not clean the ice machine with flammable liquid. Failure to do so may result in fire or explosion.
- Do not use mechanical devices or other means to accelerate the defrosting process, other than those recommended by the manufacturer.
- Do not damage the refrigerant circuit.
- Do not use if the service life is exceeded.
- Only dispose of the unit according to Federal and Local Regulations. Used device must be returned to official collection point for recycling of electrical electronic devices. To find these collection systems please contact to your local authorities or retailer where the product was purchased.
- Clean water tanks if they have not been used for 48 h.
- **WARNING:** Do not use electrical appliances inside the food storage compartments of the appliance, unless they are of the type recommended by the manufacturer.



WARNING Electrical safety

- Voltage power from outlet must match specifications on appliance nameplate.
- This appliance must be grounded.
- If the power cord is damaged, it must be replaced by a manufacturer, service agent or similar qualified person to avoid danger.
- Using an extension cord may cause overheating and increase the risk of fire.
- **WARNING:** When positioning the appliance, ensure the supply cord is not trapped or damaged.
- **WARNING:** Do not locate multiple portable socket-outlets or portable power supplies at the rear of the appliance
- Do not operate if any component, including the cord or plug is damaged.
- Unplug the unit before cleaning by hand.
- Do not touch the evaporator with your hands while the ice maker is operating.
- Do not plug in or unplug the unit with wet hands.
- Do not immerse any part of the unit in water.



WARNING Child safety

- This appliance can be used by children aged from 8 years and above and persons with reduced physical, sensory or mental capabilities or lack of experience and knowledge if they have been given supervision or instruction concerning use of the appliance in a safe way and understand the hazards involved.
- Cleaning and user maintenance not be made by children without supervision.
- Children aged from 3 to 8 years allowed to load and unload refrigerating appliances.
- Do not place the power cord where it could be pulled by children or pose a tripping hazard.
- Children should not be left unattended near the ice maker during operation.
- Children should be supervised to ensure that they do not play with the appliance.
- Destroy carton, plastic bags, and any exterior wrapping material immediately after the product is unpacked.



CAUTION

- Fill with potable water only. Do not use water that is micro-biologically unsafe or of unknown quality.
- Check if there is any water leakage after adding water to the ice machine.
- Although the machine has been tested and cleaned at the factory, due to long-term transportation and storage, please dump the ice cubes made in the first 4 cycles.
- If the machine has not been used for a long time, please clean it thoroughly before use. Please follow the instructions provided to clean and disinfect. Do not leave any solution after cleaning.
- Do not remove any safety, warning, or product information labels from the unit.
- Install the machine away from the following factors, such as wind, rain, water mist or an electromagnetic environment.
- The use of ice makers must comply with national and local standards.
- In order for the machine to work properly, please lay it flat during use. Under no circumstances should the ice machine be inclined more than 45 degrees.

SPECIFICATIONS

Product model	ICE12B
Voltage/Frequency	220-240V~/50Hz
Working Power	180W
Electric Current	1.0A
Water Reservoir	1.3L
Ice Basket Capacity	0.45kg
Ice-Making Rate	12kg per Day
Ice Shape	Bullet
Ice Size	Small or Large
Material	ABS, PP, HIPS
Net Weight	6.6kg
Unit Size	295.7 x 213 x 295mm

PRODUCT OVERVIEW

Names of components

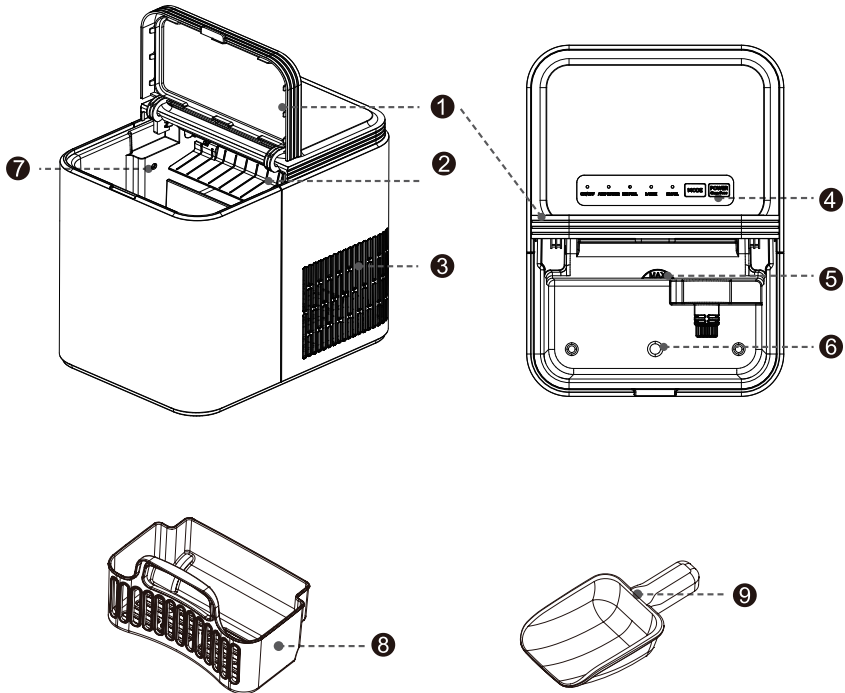

- | | | | |
|---|-------------------------|---|---------------|
| 1 | Large Viewing Window | 2 | Ice Shovel |
| 3 | Air Exhaust Fan | 4 | Control Panel |
| 5 | Maximum Water Fill Line | 6 | Drain Plug |
| 7 | Ice Full Sensor | 8 | Ice Basket |
| 9 | Ice Scoop | | |

ATTENTION

- The picture above is only for reference. The actual configuration will depend on the physical product or statement by the distributor

OPERATION INSTRUCTIONS

Control panel operation

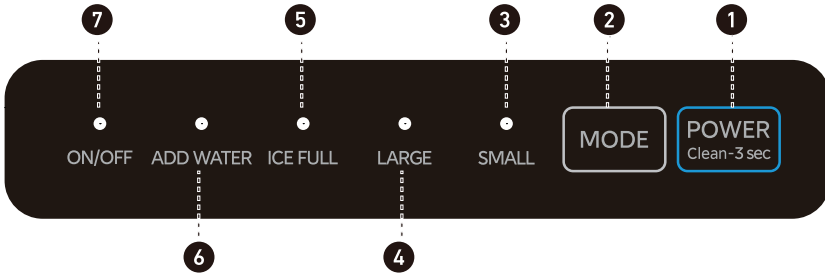

1	POWER Clean-3 sec	<p>Short press the POWER/Clean-3 sec button to turn the ice maker on.</p> <p>Short press the POWER/Clean-3 sec button to turn the ice maker off.</p> <p>In standby mode, press and hold the POWER/Clean-3 sec button for 3 seconds and the ice maker will switch to self-cleaning mode.</p>
2	MODE	Confirms large ice mode or small ice mode.
3	SMALL	The indicator light turns white when small ice mode is selected.
4	LARGE	The indicator light turns white when large ice mode is selected.
5	ICE FULL	The indicator light turns white when the ice basket is full.
6	ADD WATER	The indicator light turns white when the water reservoir low.
7	ON/OFF	<p>The indicator light turns white when the power button is on.</p> <p>The indicator light turns off when the power button is off.</p>

ATTENTION

- The actual control panel may differ from model to model.
- The ice maker enters standby mode by default upon initial power-on. All lights on the display panel illuminate for 3 seconds, indicating the default large ice mode. After 3 seconds, the lights turn off, and the unit remains in standby mode.

Before first use

1. Stand upright for 24hrs.

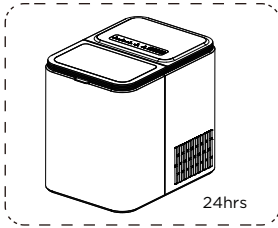

Check for accessories.

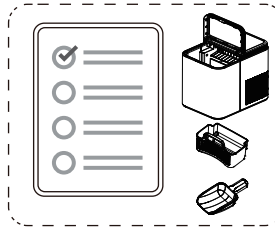

Missing parts?
Contact us.



2. Clean the ice maker thoroughly before first use.

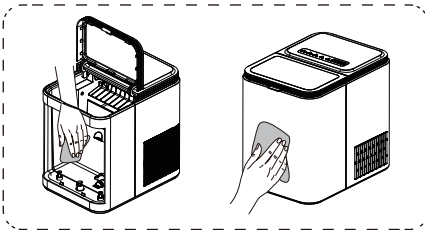

Discard first 4 cycles of ice.

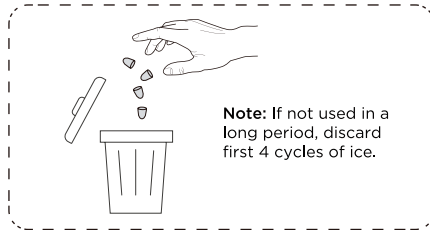

Use in locations 50°F - 90°F.

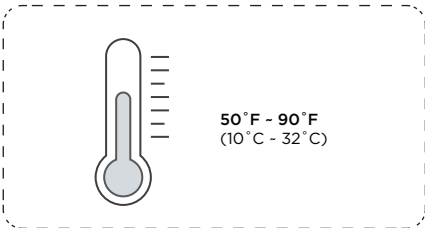

Perfect ice shape.

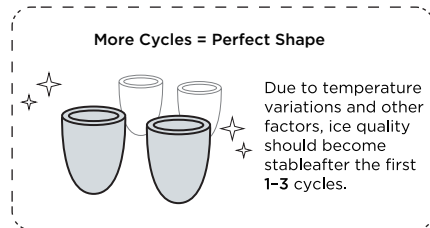

3. What Not To Do!
Unstable base.

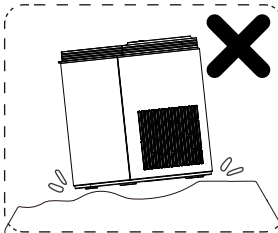

No other liquids
(Drinking water only).

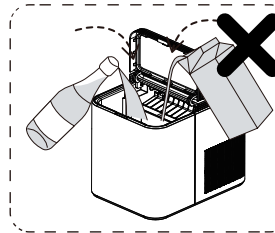

Do not use in high or low temps.

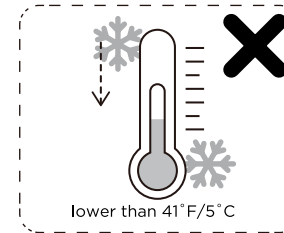

How to use your ice maker

Open cover and remove basket.

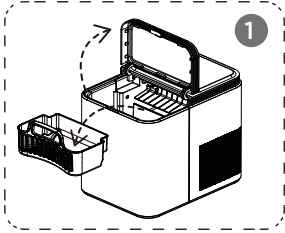

Pour water, do not exceed the "MAX" water mark.

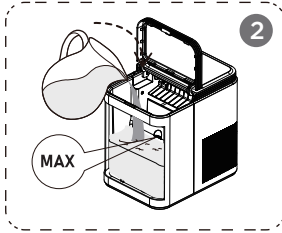

Press the **POWER** button.

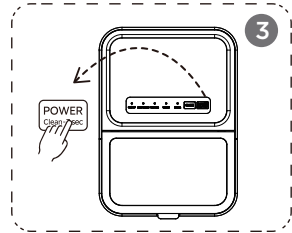

Press **MODE** button to choose ice cube size.

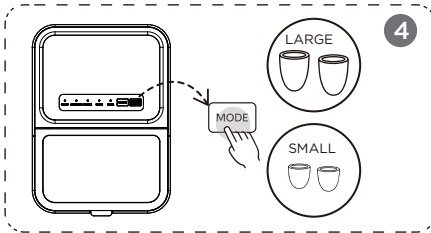

Wait for 6mins-9mins.

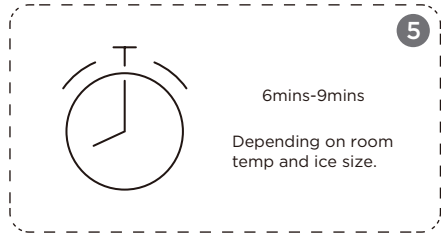

Ice full and ready when "ICE FULL" indicator turns white.

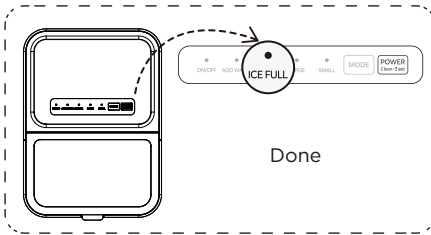

When "ADD WATER" indicator turns white, add water and press **POWER** button. (The Power button operation interval should be greater than 3s)

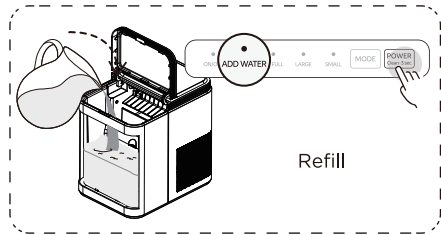

Take ice cubes out in time to avoid melting.

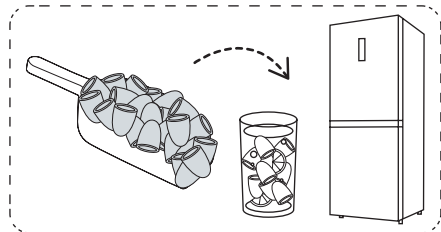

CLEANING AND MAINTENANCE

To keep your ice tasting fresh and the unit looking great, we recommend cleaning the unit once per week.

Self-cleaning

1. Remove the basket and add water.

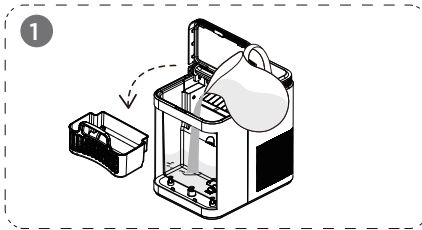

2. Hold for 3 sec to start self-cleaning.
(Complete flushing after 5 minutes)

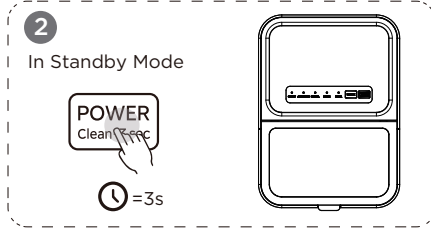

3. Drain water reservoir.

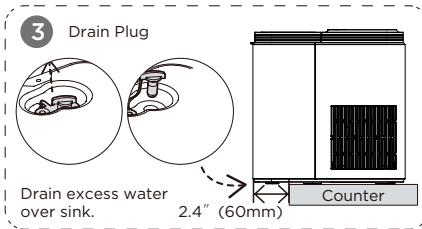

4. Clean exterior with cloth and mild dishwashing soap.

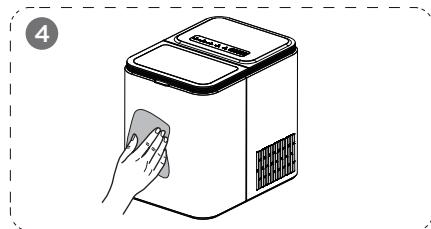

Manual cleaning

Turn o the unit and disconnect from power outlet before cleaning.

1. Remove the basket.

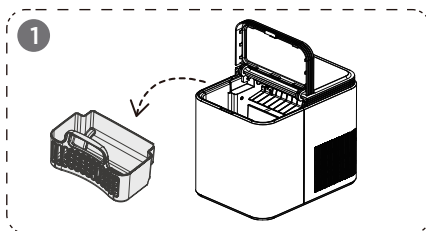

2. Clean using a soft cloth with warm water and vinegar. Clean the water filter, ice shovel and the evaporator to avoid dirt buildup.

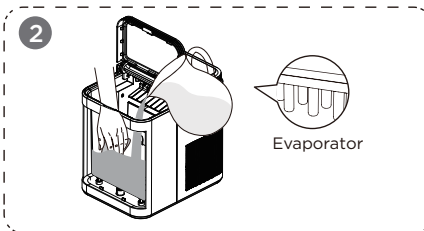

3. Drain water reservoir.

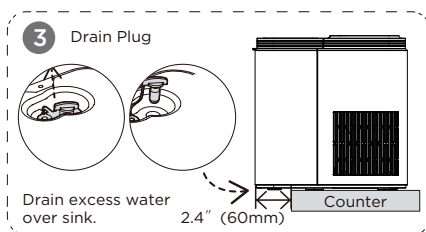

4. Clean exterior with cloth and mild dishwashing soap.

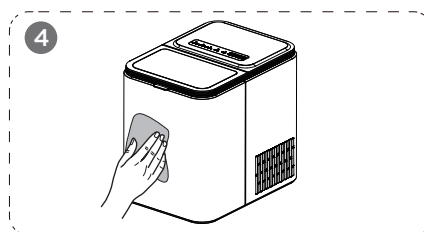

CAUTION DO's & DON'Ts while cleaning and maintaining

- Do not use organic solvent, boiled water, detergent, strong acid and strong alkali etc. for cleaning.
- When the unit is not to be used for a long duration, drain the water completely & dry the interior.
- Store in a well-ventilated area.

TROUBLESHOOTING

The following simple issues can be handled by the user. Please call the after-sale service department if the issues are not solved.

Problem	Possible Causes	Solution
Poor ice shape or quality.	Poor heat dissipation.	Leave a 3-inch clearance on all sides of the ice maker for ventilation.
	The water temperature is too high.	Fill with water temperature between 46°F and 77°F.
	The water temperature is too high.	Use the ice maker in room temperatures between 50°F and 90°F.
	Evaporator deformation.	Please contact customer service.
Ice maker creating loud noise.	Ice maker has not been cleaned for a long time, which will form a sticky substance around the inlet of the water pump.	Clean every 1 to 2 weeks, using some neutral cleaning agents (such as mild vinegar solution and soapy water).
	Lack of water to pump will create noise when pumping water.	Add more water.
	Fan or ice maker is damaged.	Please contact customer service.
	Water pump is damaged.	
"ICE FULL" indicator light is on.	Ice is blocking the infrared sensor.	Empty the ice basket. (After the full ice warning is cleared, the compressor will restart and ice making will resume within 2 minutes.)
	Infrared sensors do not work.	1. Wipe the infrared sensors clean. 2. Contact customer service if the infrared sensors still don't work.
Ice sticks together.	Making ice takes too long.	Stop making ice. After the ice melts, restart and try again.
	The water temperature is too low.	Fill with water temperatures between 46°F and 77°F.
	Evaporator deformation.	Please contact customer service.
Not making ice.	Ambient or water temperature is too high.	Please contact customer service.
	Water pump is damaged.	
	Refrigerating system leaking.	
	Refrigerating system blocked.	
	The fan stopped working.	
	The wires are loose.	
The gears in the motor are broken.		
"ADD WATER" indicator light is on.	Water tank water level is too low, cannot start ice making.	Add water, press the POWER button to restart the machine, and once the water shortage prompt is resolved, the ice-making will begin.

