

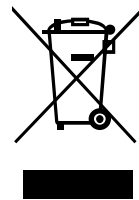

IN250800018V02_UK_FR_DE_ES_IT

833-623V72_833-623V92

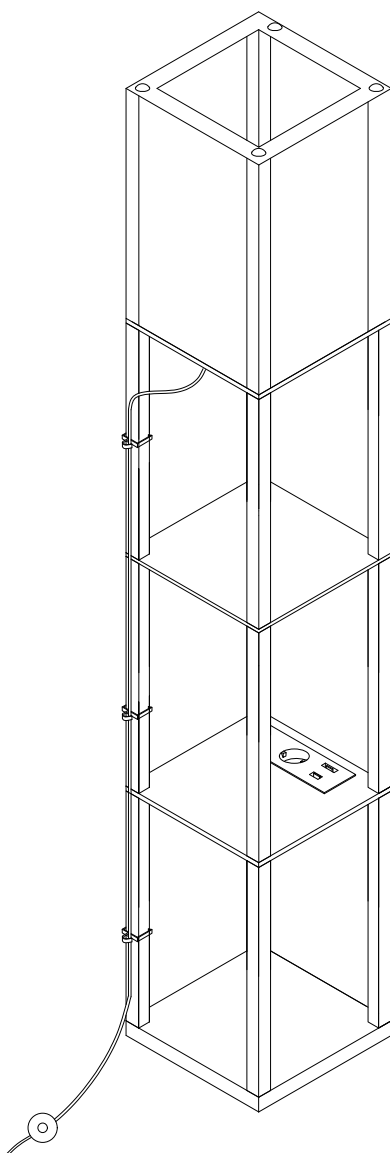

EN_IMPORTANT, RETAIN FOR FUTURE REFERENCE: READ CAREFULLY.

FR_IMPORTANT : A LIRE ATTENTIVEMEN ET A CONSERVER POUR VOUS Y REFERER ULTERIEUREMENT.

ES_IMPORTANTE, LEA Y GUARDE PARA FUTURAS REFERENCIAS.

PT_IMPORTANTE, RETER PARA REFERÊNCIA FUTURA: LEIA ATENTAMENTE.

DE_WICHTIG! SORGFÄLTIG LESEN UND FÜR SPÄTER NACHSCHLAGEN AUFBEWAHREN.

IT_IMPORTANTE! CONSERVARE IL PRESENTE MANUALE PER FUTURO RIFERIMENTO E LEGGERLO ATTENTAMENTE.

Specification

Model	833-623V72_833-623V92
Max power(Bulb)	40W
Input Voltage/Frequency	AC220-240V~ 50Hz
Output (USB-A+Type-C)	Max 1500W Max 5V 2.1A

CAUTION



INDOOR USE ONLY

- Keep out of reach of children and animals.
- Do not use in the bathroom or damp places.
- Place the lamp on a flat surface and ensure it is placed away from any flammable materials.
- Before cleaning the lamp, ensure it is switched off.
- Do not pull the plug out of the socket with wet hands.
- If the supply cord is damaged, it must be replaced by the manufacturer, its service agent or similarly qualified persons in order to avoid a hazard.
- Do not touch light bulb while fixture is turned on.
- Never look directly at a lit bulb.
- **Notice: Do not repeatedly turning the light on and off.**

CARE INSTRUCTIONS:

- Unplug lamp before cleaning.
- Wipe clean with a soft, dry cloth or static duster.
- Always avoid the use of harsh chemicals or abrasive cleaners as they may cause damage to the fixture's finish.

*** Do not discard any contents until after assembly is complete to avoid accidentally discarding small parts or hardware.**

- **This product contains a light source of energy efficiency class <F>.**

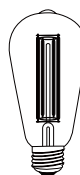

**LED/Energy-saving
lamp
E27 base**

**DO NOT EXCEED THE
SPECIFIED WATTAGE.**

Spécification

Modèle	833-623V72_833-623V92
Puissance Max(Ampoule)	40W
Tension d'entrée/Fréquence	AC220-240V~ 50Hz
Sortie (USB-A+Type-C)	Max 1500W Max 5V 2.1A

MISE EN GARDE



À USAGE INTÉRIEUR EXCLUSIVEMENT

- Tenir hors de portée des enfants et des animaux.
- Ne pas utiliser dans la salle de bains ou dans des endroits humides.
- Placez la lampe sur une surface propre et assurez-vous qu'elle soit placée à l'écart de toute matière inflammable.
- Avant de nettoyer la lampe, assurez-vous qu'elle soit éteinte .
- Ne tirez pas la prise avec les mains mouillées.
- Si le câble d'alimentation est endommagé, il doit être remplacé par le fabricant, son service après vente ou des personnes de qualification similaire afin d'éviter un danger.
- Évitez de toucher l'ampoule pendant que le luminaire est sous tension.
- Évitez toujours de regarder directement une ampoule allumée.
- Remarque : N'allumez pas et n'éteignez pas la lumière à plusieurs reprises.

INSTRUCTIONS D'ENTRETIEN :

- Déconnectez le luminaire avant de le nettoyer.
 - Essuyez-le proprement à l'aide d'un chiffon doux et sec ou d'un essuie-meuble statique.
 - Évitez toujours d'utiliser des produits chimiques forts ou agents nettoyants abrasifs, car ils pourront endommager la finition du luminaire.
- * Ne jetez pas le contenu avant d'avoir terminé l'assemblage afin d'éviter de jeter accidentellement de petites pièces ou des accessoires matériels.**
- **Ce produit contient une source lumineuse de classe d'efficacité énergétique <F>.**

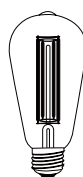

DÉL/Lampe à économie d'énergie
Base E27

NE PAS DÉPASSER LA PUISSANCE INDIQUÉE.

Spezifikationen

Modell	833-623V72_833-623V92
Max. Leistung (Glühbirne)	40W
Eingangsspannung/Frequenz	AC220-240V~ 50Hz
Ausgang (USB-A+Type-C)	Max 1500W Max 5V 2.1A

VORSICHT



NUR ZUR VERWENDUNG IN INNENRÄUMEN

- Außerhalb der Reichweite von Kindern und Tieren aufbewahren.
- Nicht im Badezimmer oder in feuchten Räumen verwenden.
- Stellen Sie die Lampe auf eine ebene Fläche und halten Sie sie von brennbaren Materialien fern.
- Vergewissern Sie sich vor dem Reinigen der Lampe, dass sie ausgeschaltet ist.
- Ziehen Sie den Stecker nicht mit nassen Händen aus der Steckdose.
- Wenn die Netzanschlussleitung dieses Gerätes beschädigt wird, muss sie durch den Hersteller oder seinen Kundendienst oder eine ähnlich qualifizierte Person ersetzt werden, um Gefährdungen zu vermeiden.
- Berühren Sie die Glühbirne nicht, wenn das Gerät eingeschaltet ist.
- Schauen Sie nie direkt in eine leuchtende Glühbirne.
- **Beachten Sie: Schalten Sie die Leuchte nicht wiederholt ein und aus.**

PFLEGEHINWEISE:

- Ziehen Sie vor der Reinigung den Netzstecker.
- Wischen Sie das Leuchtmittel mit einem weichen, trockenen Tuch oder einem Staubtuch ab.
- Vermeiden Sie die Verwendung von scharfen Chemikalien oder Scheuermitteln, da diese die Oberfläche der Leuchte beschädigen können.
- *** Entsorgen Sie jeglichen Inhalt erst nach Abschluss der Montage, um ein versehentliches Entsorgen von Kleinteilen oder Hardware zu vermeiden.**
- **Dieses Produkt enthält eine Lichtquelle der Energieeffizienzklasse <F>.**

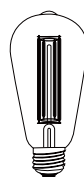

LED/Energiesparlampe
E27 Basis

**ÜBERSCHREITEN SIE
DIE
VORGESCHRIEBENE
WATTZAHL NICHT.**

Especificaciones

Modelo	833-623V72_833-623V92
Potencia máxima (Bombilla)	40W
Voltaje de entrada/Frecuencia	AC220-240V~ 50Hz
Salida (USB-A+Type-C)	Max 1500W Max 5V 2.1A

PRECAUCIÓN



USO SOLO EN INTERIORES

- Mantener fuera del alcance de los niños y animales.
- No lo use en el baño o en lugares húmedos.
- Coloque la lámpara sobre una superficie limpia y asegúrese de que está colocada lejos de cualquier material inflamable.
- Antes de limpiar la lámpara, asegúrese de que esté apagada.
- No tire del enchufe con las manos mojadas.
- Si el cable de suministro está dañado, debe ser reemplazado por el fabricante, su agente de servicio o personas igualmente calificadas para evitar un peligro.
- No toque las bombillas mientras el aparato esté encendido.
- Nunca mire directamente a una bombilla encendida.
- **Aviso: No encienda y apague la luz repetidamente.**

INSTRUCCIONES DE MANTENIMIENTO:

- Desenchufe la lámpara antes de limpiarla.
 - Limpie con un paño suave y seco o un plumero estático.
 - Evite siempre el uso de productos químicos agresivos o limpiadores abrasivos, ya que pueden dañar el acabado del aparato.
- * **No deseche ningún contenido hasta que se haya completado el montaje para evitar desechar accidentalmente piezas pequeñas o herrajes.**
- **Este producto contiene una fuente de luz de clase de eficiencia energética <F>.**

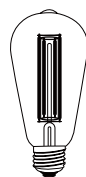

LED/Lámpara de bajo consumo
Base de E27

NO EXCEDA LA POTENCIA ESPECIFICADA

Especificações

Modelo	833-623V72_833-623V92
Potência máxima (Lâmpada)	40W
Tensão de entrada/Frequência	AC220-240V~ 50Hz
Saída (USB-A+Type-C)	Max 1500W Max 5V 2.1A

DEPÓSITO



USO APENAS EM INTERIORES

- Manter fora do alcance das crianças e dos animais.
- Não utilizar na casa de banho ou em locais húmidos.
- Coloque o candeeiro numa superfície plana e certifique-se de que está afastado de quaisquer materiais inflamáveis.
- Antes de limpar o candeeiro, certifique-se de que está desligado.
- Não retire a ficha da tomada com as mãos molhadas.
- Se o cabo de alimentação estiver danificado, deve ser substituído pelo fabricante, seu agente de serviço ou pessoas igualmente qualificadas para evitar riscos.
- Não tocar na lâmpada enquanto o aparelho estiver ligado.
- Nunca olhar diretamente para uma lâmpada acesa.
- **Aviso: Não ligar e desligar repetidamente a luz.**

INSTRUÇÕES DE MANUTENÇÃO:

- Desligue a lâmpada da tomada antes de a limpar.
 - Limpe com um pano macio e seco ou com um espanador estático.
 - Evite sempre a utilização de produtos químicos agressivos ou de produtos de limpeza abrasivos, pois podem danificar o acabamento do aparelho.
- * Não descartar qualquer conteúdo até que a montagem esteja concluída para evitar descartar acidentalmente pequenas peças ou ferragens.**
- **Este produto contém uma fonte de luz de classe de eficiência energética <F>.**

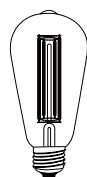

LED/Lâmpada de baixo consumo
Base E27

NÃO EXCEDER A POTÊNCIA ESPECIFICADA.

Specifiche

Modello	833-623V72_833-623V92
Potenza massima (Lampadina)	40W
Tensione di ingresso/Frequenza	AC220-240V~ 50Hz
Uscita (USB-A+Type-C)	Max 1500W Max 5V 2.1A

ATTENZIONE



SOLO PER USO INTERNO

- Tenere fuori dalla portata dei bambini e degli animali.
- Non utilizzare in bagno o in luoghi umidi.
- Posizionare la lampada su una superficie piana e accertarsi che sia posizionata lontano da qualsiasi materiale infiammabile.
- Prima di pulire la lampada, assicurarsi che sia spenta.
- Non tirare la spina dalla presa con le mani bagnate.
- Se il cavo di alimentazione è danneggiato, deve essere sostituito dal produttore, dal suo agente di servizio o da persone similmente qualificate per evitare pericoli.
- Non toccare la lampadina quando l'apparecchio è acceso.
- Non guardare mai direttamente la lampadina accesa.
- Attenzione: Non accendere e spegnere ripetutamente la lampadina.

ISTRUZIONI PER LA CURA:

- Scollegare la lampada prima di pulire.
- Pulire con un panno morbido e asciutto o con uno spolverino statico.
- Evitare sempre di usare prodotti chimici aggressivi o detergenti abrasivi perché potrebbero danneggiare la finitura dell'apparecchio.

*** Non gettare qualsiasi contenuto fino a quando non è completato l'assemblaggio, per evitare di gettare accidentalmente piccole parti o accessori.**

- **Questo prodotto contiene una sorgente luminosa di classe di efficienza energetica <F>.**

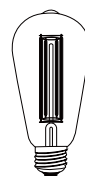

**LED/Lampada a risparmio energetico
E27 Base**

NON SUPERARE LA POTENZA SPECIFICATA.

PARTS

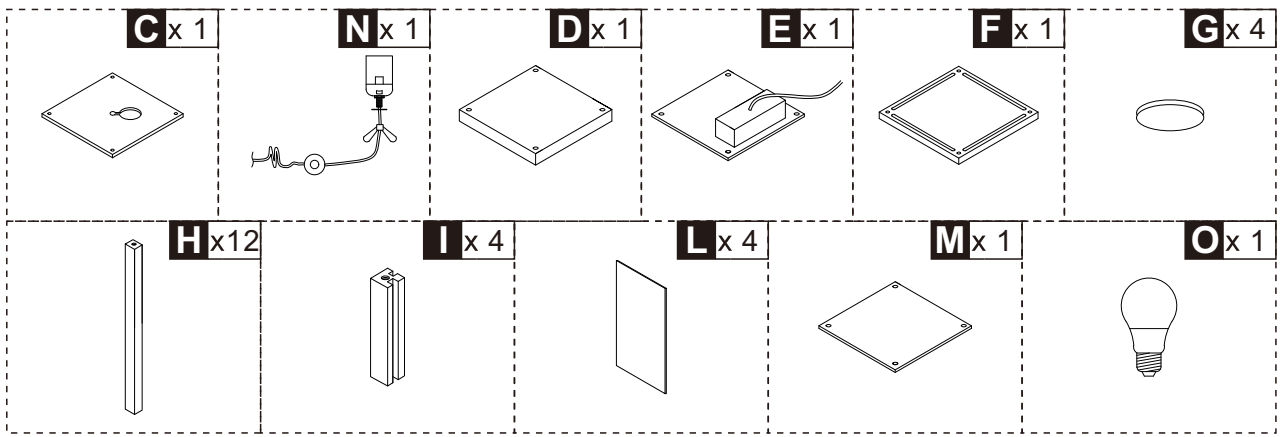

HARDWARE

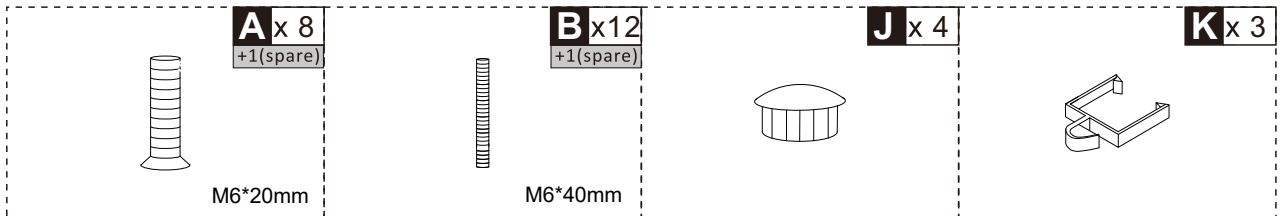

01

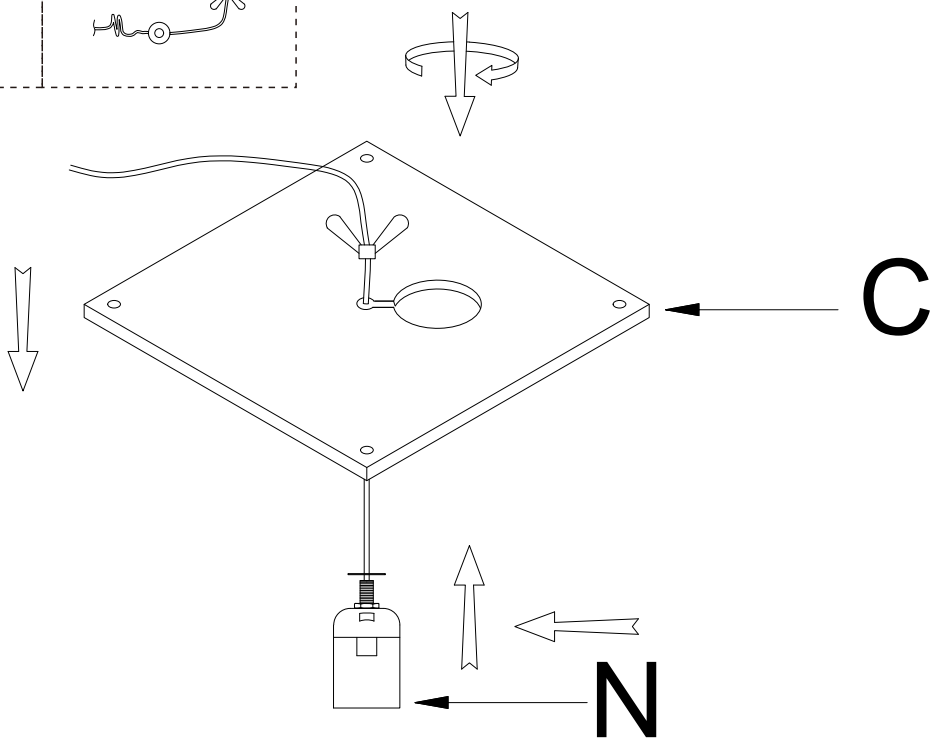
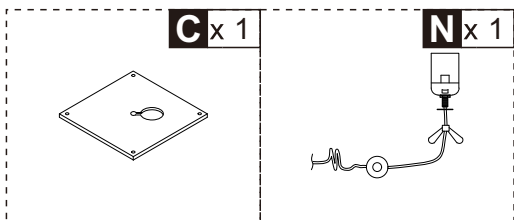

02

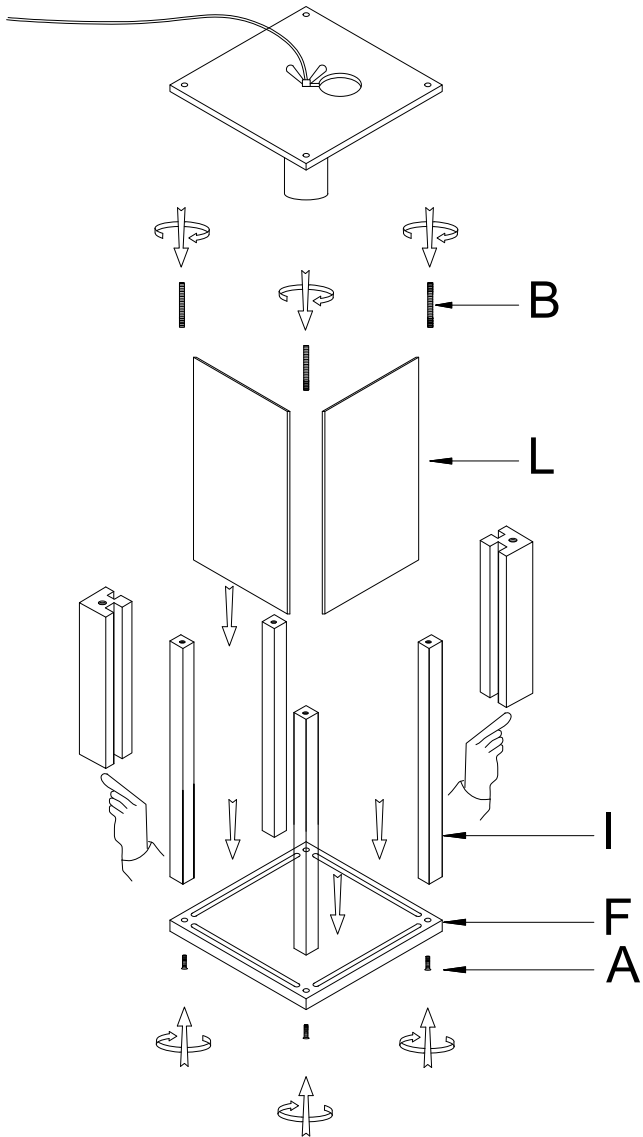
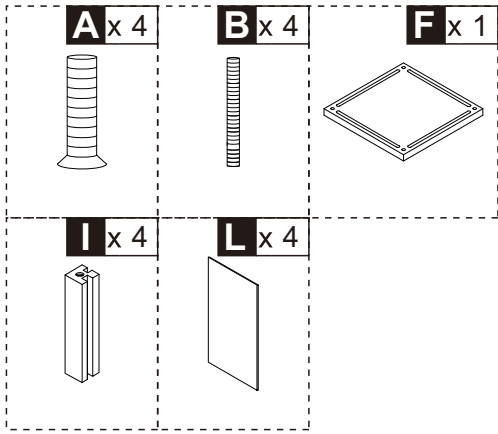

03

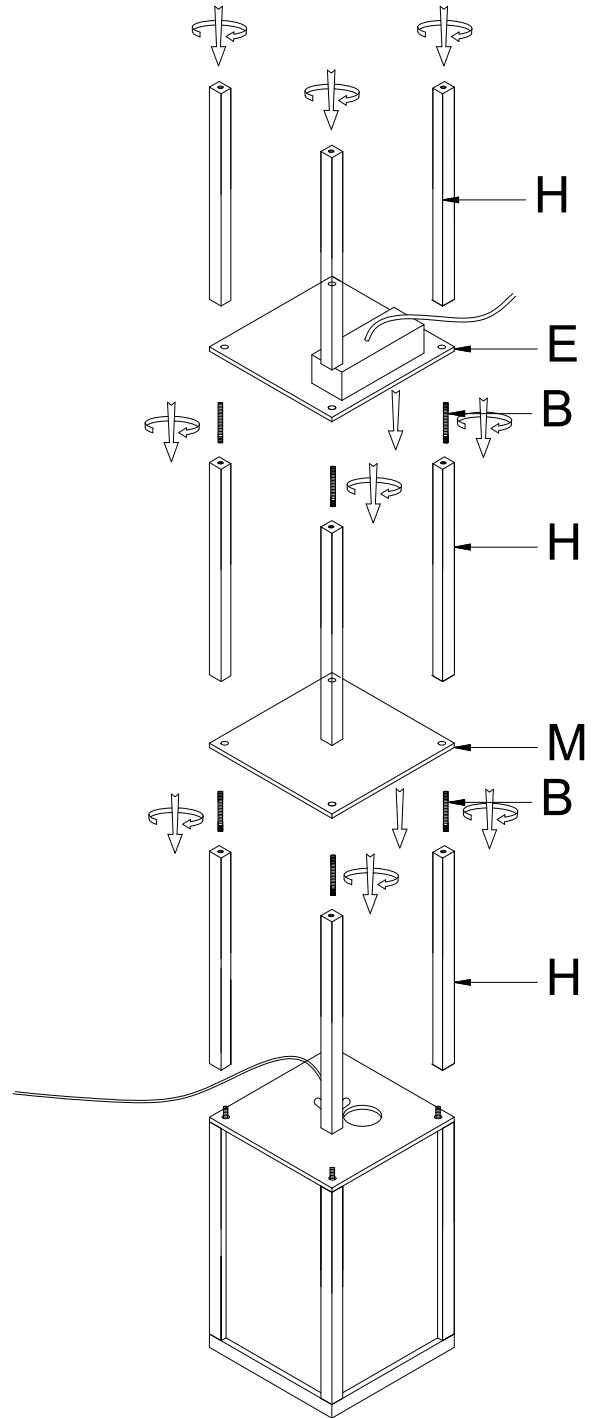
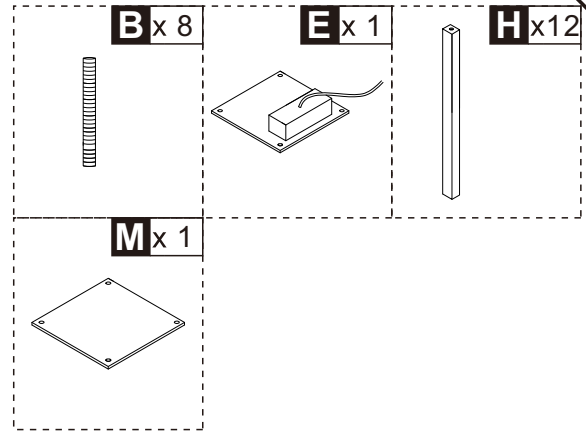

A x 4

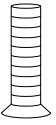

D x 1

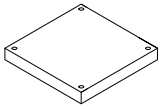

G x 4



K x 3

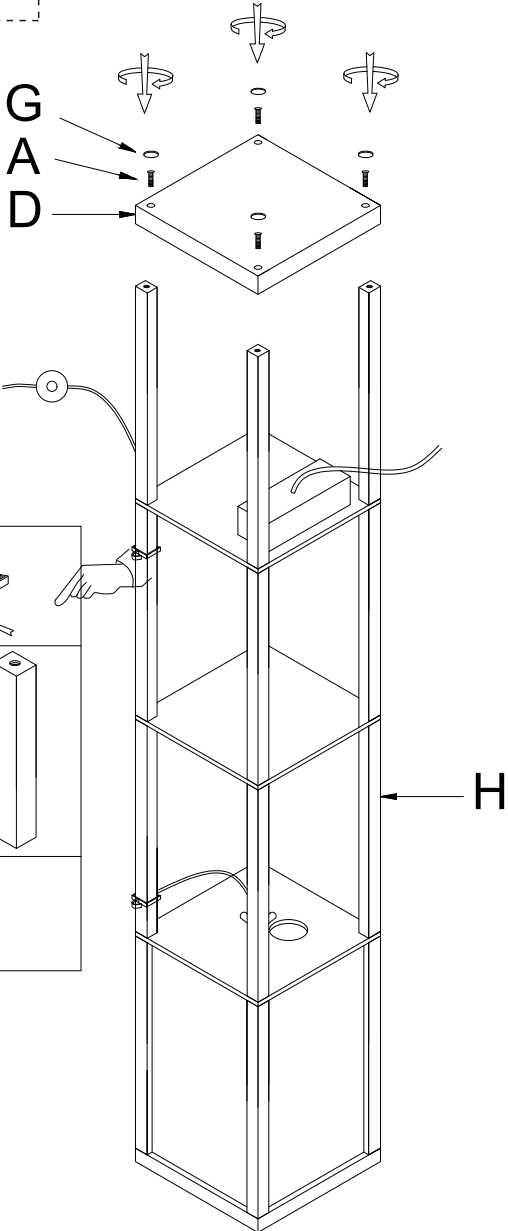
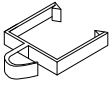

J x 4



O x 1

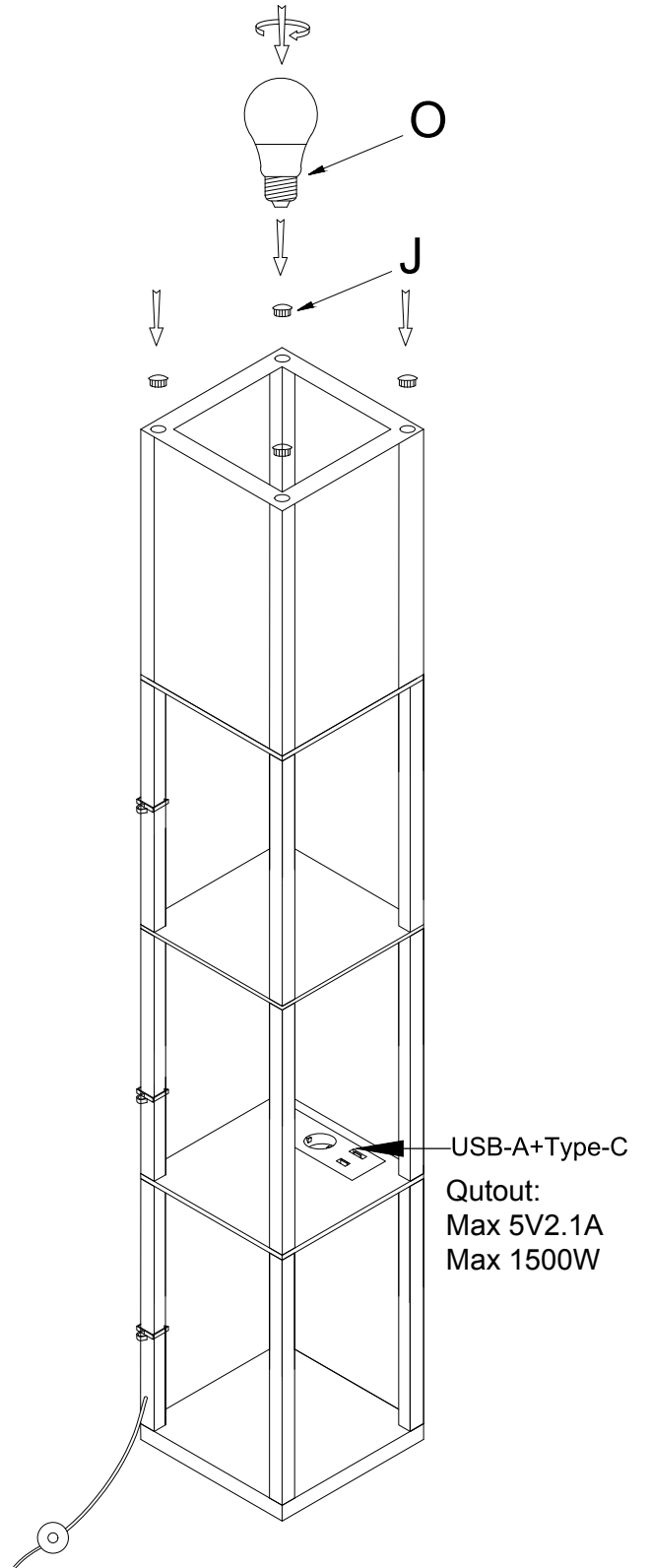

UK

If you have any questions, please contact our customer care center.

Our contact details are below:



0044-800-240-4004



enquiries@mhstar.co.uk

IMPORTER ADDRESS:

MH STAR UK Ltd

1 Northampton Cross Logistics Park

Northampton Cross Road

Northampton

NN4 9FH

MADE IN CHINA

ES

Si tiene alguna pregunta, comuníquese con nuestro Centro de Atención al Cliente.

Nuestros datos de contacto son los siguientes:



0034-931294512



atencioncliente@aosom.es

Importador/Fabricante/REP:

Spanish Aosom, S.L.

C/ Roc Gros, N° 15. 08550, Els Hostalets de Balenyà, Spain.

B66295775

atencioncliente@aosom.es

TEL: 931294512

HECHO EN CHINA

FR

Si vous avez la moindre question, veuillez contacter notre centre d'assistance à la clientèle.

Nos coordonnées sont les suivantes:



0033-1-84166106



aosom@mhfrance.fr

Importé par/Fabricant/REP:

MH France

2,rue Maurice Hartmann

92130Issy-les-Moulineaux

France

Fabriqué en Chine

PT

Se tiver alguma dúvida, por favor contacte o nosso Centro de Atendimento ao Cliente.

Os nossos dados de contacto são os seguintes:



0034-931294512



info@aosom.pt.

IMPORTADOR:

SPANISH AOSOM, S.L

C.ROC GROS N.15, 08550. ELS HOSTALETES DE BALENYÀ

TEL: 931294512 (SEG-SEX DAS 7:30H ÀS 16:30H)

INFO@AOSOM.PT

WWW.AOSOM.PT

DE

Wenn Sie Fragen haben, wenden Sie sich bitte an unser Kundendienstzentrum.

Unsere Kontaktdaten stehen unten:



0049-0(40)-87408465



service@aosom.de

Importeur/Hersteller/REP:

MH Handel GmbH

Wendenstraße 309

D-20537 Hamburg

Germany

IN CHINA HERGESTELLT

IT

In caso di dubbio, si prega di contattare il nostro centro assistenza clienti.

I nostri dettagli di contatto sono di seguito:



0039-0249471447



clienti@aosom.it

IMPORTATO DA/Produttore/REP:

AOSOM Italy srl

Centro Direzionale Milanofiori

Strada 1 Palazzo F1

20057 Assago (MI)

P.1.: 08567220960

FATTO IN CINA



FR

Cet appareil,
ses accessoires,
cordons et batteries
se recyclent

REPRISE
À LA LIVRAISON



OU

À DÉPOSER
EN MAGASIN



OU

À DÉPOSER
EN DÉCHÈTERIE



Points de collecte sur www.quefairedemesdechets.fr
Privilégiez la réparation ou le don de votre appareil !

Aosom