

USER MANUAL

RUNNERDTM400i

Runner DTM400i Treadmill - DU

Copyright © Flow Fitness.

All rights reserved. Nothing in this instruction manual may be used or reproduced in any form or way without the express written permission of Flow Fitness.

1. Important information	4
1.1 Health	4
1.2 Safety	4
2. Introduction	6
2.1 Contents of package	7
2.2 Important parts	8
2.3 Specifications	9
3. Fitness	10
3.1 Training by heart rate	10
3.2 Warming up and cooling down	12
3.3 Assembly	13
3.4 Storage / Prepare for use	18
3.5 Use of the computer	19
3.6 Connect the Fitshow app	24
3.7 Maintenance	26
4. General information	28
4.1 Training schedule	28
4.2 Exploded view	30
4.3 Troubleshooting	32
5. Warranty	33
5.1 Warranty	33

1. Important information

1.1 Health

Important:
read this instruction manual first and follow the instructions carefully before using the product.

- Consult an expert to determine the training level that is most suitable for you.
- If you experience any dizziness, nausea or any other physical discomfort while training, cease the training immediately and consult a physician.
- Watch your heart beat during the training and immediately stop training when values are inconsistent.
- We advise you to do warming up and cooling down exercises during five to ten minutes before and after use of the product. This way your heart rate can increase and decrease gradually and you can prevent painful muscles.

1.2 Safety

- Only use this product as described in this instruction manual.
- Before using this product check that the product functions as it should. In case of malfunction or a defect stop training immediately and contact your vendor.
- Do not use the product when there is a malfunction.
- The product is only meant for use in the home and it has to be positioned on a flat surface.
- The product can only be used by one person at the time.
- The product can be used by persons with a body weight of up to 120 kilos.
- Always make sure that there is at least one meter of free space in all directions around the product when you are training.
- Don't stick any objects in any opening of the equipment.
- Keep children and pets away from the product.
- Handicapped persons should get consent from a medical expert and follow their directions for training with the product.
- Do not place hands or feet under the product.

1. Important information

- Never hold your breath during a training session. Your breathing should be at a normal interval depending on the intensity of the training.
- Start your training schedule slowly and build it up gradually.
- Always wear appropriate clothing during training. Don't wear anything that's too loose and can get caught between moving parts of the equipment.
- When moving the equipment always use the appropriate lifting techniques to prevent back injury.
- Check screws and bolts regularly and fasten them if they are loose.
- The owner of the product is responsible for all users to be aware of the warnings and instructions as mentioned in this instruction manual.
- This product is intended for use in a clean and dry environment. Storage in cold and / or moist areas could lead to problems with the product.
- This product is not suitable for therapeutic supports / or professionally use in physical therapy.

WARNING

Have your physical condition checked by a licensed physician before you start training. This is particularly important for persons over 35 years old or persons who have any problems with their health. Read all instructions before using the equipment. Flow Fitness is not responsible for any personal injury or damage to property caused by the use of this equipment.

This product is not suited for rental or use in a commercial or professional environment.

2. Introduction

Thank you for purchasing the Runner DTM400i Treadmill.

This manual contains all information necessary for the use and operation of the treadmill.
This guide also contains tips and advice on how to train.

Flow Fitness wishes you successful and enjoyable training sessions.

2.1 Contents of package



Allen tool

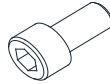

Bolts M12 4PCS

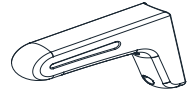

Handrail 2PCS



Power cable



Aux cable



Safety key



Lubricant

2. Introduction

2.2 Important parts



2.3 Specifications

Computer

- 12 Total programs
- 1 Manual program
- 8 Preset programs
- 3 user programs
- Bluetooth, train with the Fitshow app

Heart rate reception

- Hand pulse sensors
- Chest Belt (optional)

Size

Length: 145,5 cm
Height: 123,5 cm
Width: 74,5 cm
Weight: 57 kg

Size folded

Length: 26,5 cm
Height: 145,5 cm
Width: 74,5 cm

Technical

- Motor 1.25 HP Continuous 2.5 HP PEAK
- Incline 0 - 12% (0-12 levels)
- Speed 1-18 KPH
- Quick keys for speed and incline
- Running Deck (LxW) 130 x 48 cm
- 120 kg max user weight

Extra

- Audio AUX input
- USB charger

3. Fitness

What is fitness? In general a fitness exercise can be described as an activity that makes your heart pump more oxygen from your lungs to your muscles by means of circulating the blood. The more strenuous the training, the more fuel (oxygen) the muscles need and the more work the heart has to do to pump oxygen rich blood to the muscles. If you are in good physical shape your heart can pump more blood to the muscle with each contraction. This means the heart doesn't have to contract as many times to transport the necessary oxygen to your muscles. Your resting heart beat and heart beat when exercising will therefore decrease.

3.1 Training by heart rate

While training it is important to monitor your heart rate. The heart rate is essential for the result of your training. Your best training heart rate depends firstly on your age. Your maximum heart beat can be determined by this. Secondly the most effective heart rate depends on your training goals. If your training goal is to lose weight, then the most effective training is at 60% of your maximum heart rate. If your training goal is to improve your stamina, then you should train at 80% of your maximum heart rate.

The body stores energy in two forms: carbohydrates and fat. When we exercise we use a combination of these two energy supplies. If the training intensity is at a high level the body will mostly choose the energy that burns fast: carbohydrates. Since there is a limited supply of these carbohydrates you can't continue this for a long period of time. When training at a low intensity the body will mostly choose to use a long lasting source of energy: fat. Since this is stored in large quantities in the body, you can continue this kind of training for a longer time.

Below you will find a schedule allowing you to calculate the best heart rate for your training. In this schedule each age category has a range that your heart rate should be in during your training. The middle column has the values you should try to maintain if you want to lose weight. If you want to improve your stamina you should try to maintain the rates in the right column.

Age	Weight lost (beats per minute) 60%	Improve stamina (beats per minute) 85%
20 - 24	120 - 118	170 - 167
25 - 29	117 - 115	166 - 163
30 - 34	114 - 112	162 - 158
35 - 39	111 - 109	157 - 154
40 - 44	108 - 106	153 - 150
45 - 49	105 - 103	149 - 145
50 - 54	102 - 100	144 - 141
55 - 59	99 - 97	140 - 137
60 and older	96 - 94	136 - 133

For each individual the best way to start training is different. If you have not exercised in some time or are overweight, you should start your training schedule slowly and gradually increase the level of activity.

In the last chapter of this instruction manual you will find several different training schedules (chapter 5. general information). You can use these schedules to reach your training goals. The schedules are divided in two phases. The first phase can be used for beginners or persons who start training after a long period of inactivity. During this phase the level of intensity is built up gradually. After six weeks the second phase begins. You can then choose a training schedule to lose weight or improve your stamina.

3.2 Warming up and cooling down

A good training schedule starts with a good warming up and ends with a cooling down of the muscles. This will prevent painful muscles and injury. Below you will find some suitable exercises.



Head Roll

Tilt your head to the right. Hold this for one second, so that you feel a little pull in the muscles on the left side of your neck. Do the same for the other side, front and back. Repeat two or three times.



Toe Touch

Slowly bend forward with your back and arms relaxed. Bend as far as you can and hold the position for ten seconds. Repeat this two or three times.



Side Stretch

Extend both your arms up in the air and reach as high as you can with your right arm. Lean a bit to the left so that the muscles in the right side of your torso are stretched. Hold this position for one second. Relax and make the same motion on the other side of your body. Repeat this three or four times.



Knee bend

Set your feet shoulder-width apart and your stretched your hands out. Lower yourself no more than 10cm by bending your knees. Come back up again and repeat several times.



Lower back stretch

Begin on all fours. Stretch your arms out in front of you, allowing your face to lower to a position near the floor. Gently sit back. Rest your glutes just above your heels. Ease back and feel the gentle stretch in your lower back.



Hamstring Stretch

Sit down on the floor with your right leg extended in front of you and place the sole of your left foot on the inside of your right upper leg. Bend forward in the direction of your right foot and hold this position for ten seconds. Relax and then do the same with your other leg. Repeat two or three times.

3.3 Assembly

Step 1: Unfolding

This chapter describes how to assemble the DTM400i treadmill. Before assembling remove all parts from the box and make sure there is enough space available for the assembly.

1. Press the lever indicated in the image below with your feet or hand.
2. Now turn the computer with computer post upright until you feel the computer is fixed into place.

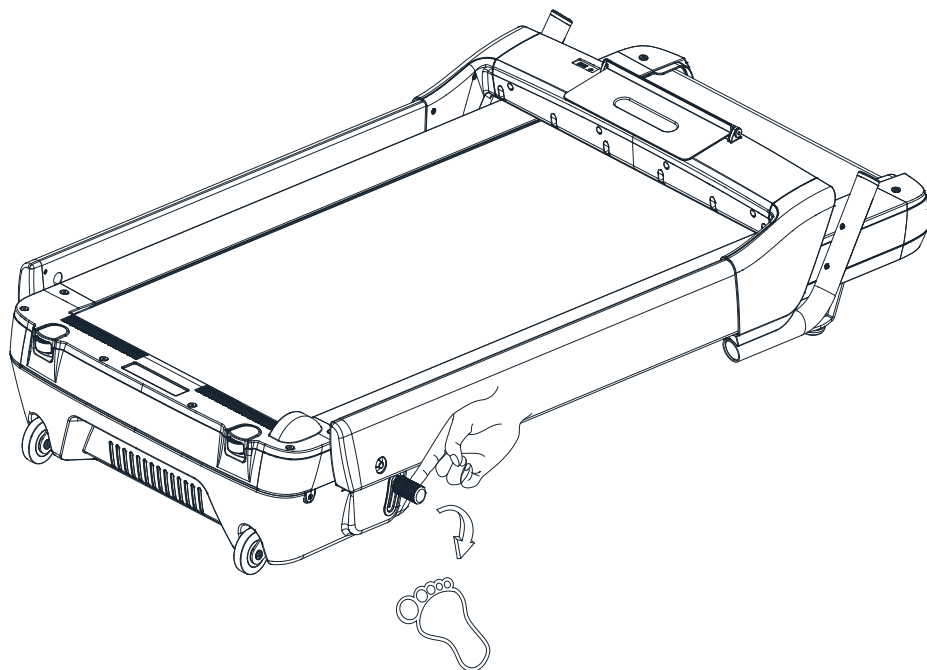

4. Use

Step 2: Assembling the extra handlebars

1. Remove the four bolt hole covers from the handlebars with hand pulse sensors.
2. Assemble the two extra handlebars (114) by fastening four bolts (75) with the included Allen tool.

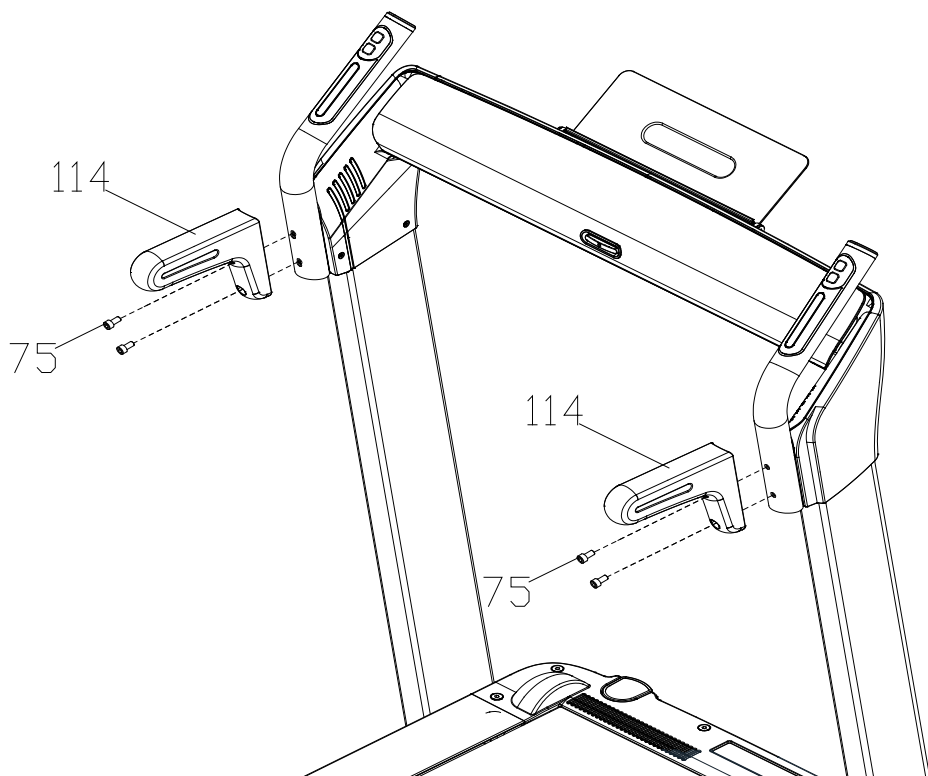

Step 3: Leveling the treadmill

With the adjusting feed you are able to level the treadmill. Rotate the adjusting feed underneath the end running deck until the deck is levelled and stand firmly on the ground. When replacing the treadmill to an other location you will need to level the treadmill again.

Step 4: Placing the safety key

Place the safety key inside the safety key holder in the middle of computer. For security reasons when exercising always place the clip on the other end of the safety key rope onto your clothes. When the safety key is removed from the holder the treadmill will make an emergency stop.

When the display show "SAFE" it indicates that the safety key is not placed or not placed correctly. Without correct placement of the safety key the computer cannot start a training exercise.

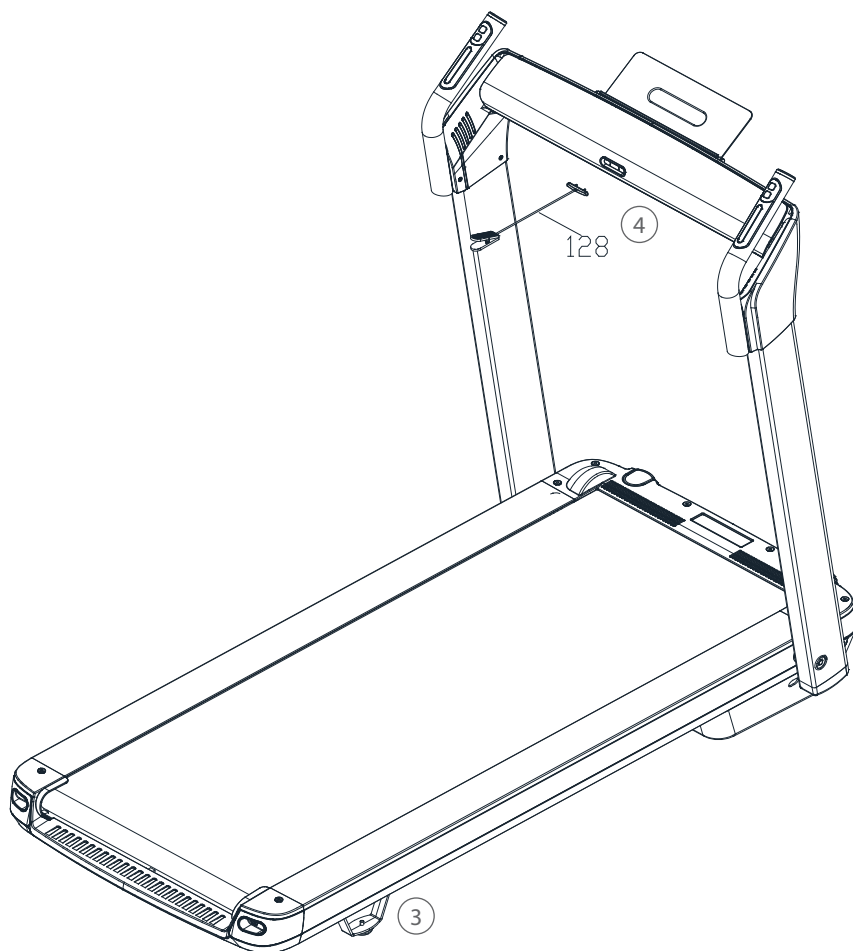

4. Use

Unfold the tablet holder

Turn the tablet holder at the back of the computer upwards until it is fixed into place.

Fold the tablet holder

Before folding press the tablet holder to the left to unlock the folding mechanism. Now you are able to fold back the tablet holder.

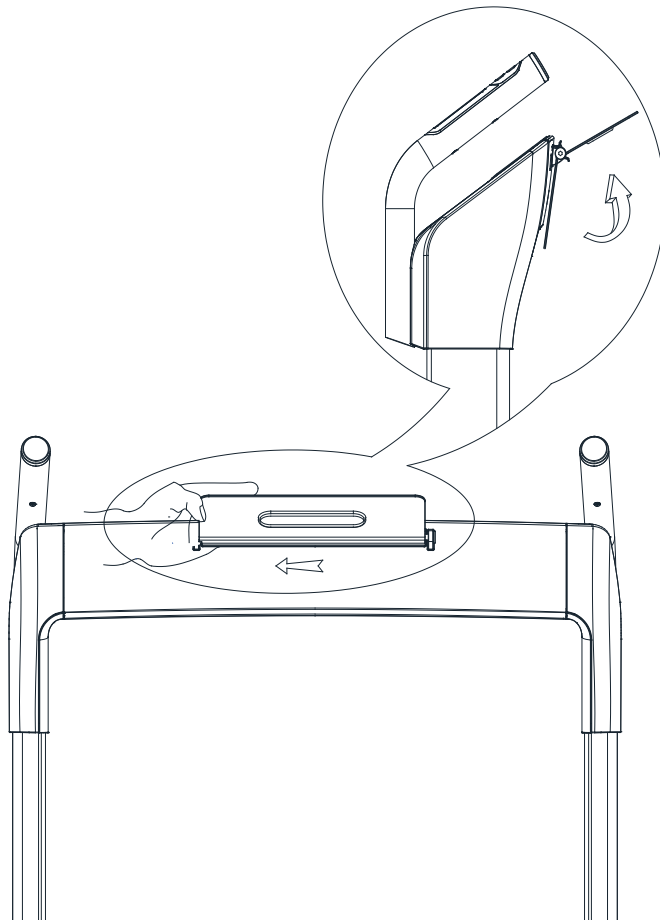

Power Supply

Before you start exercising, you must turn on the treadmill. Make sure the power cord is plugged in and the on / off switch is switched to "I". The on / off switch is located at the back of the treadmill underneath the motor cover.

For your own safety it is important that the power cord is plugged into a grounded outlet!

3.4 Storage / Prepare for use

Folding and storage

1. Before folding the treadmill remove the power cable and fold down the tablet holder.
2. Grab the handlebars and press the folding lever with your feed. Now turn the computer down towards the running deck.
3. Now extend both supporting transporting wheels as shown in the image below.
4. Lift the end of the running deck to transport the treadmill. You are able to store the treadmill horizontally or vertical. You can use the supporting transporting wheels to move the treadmill sideways.

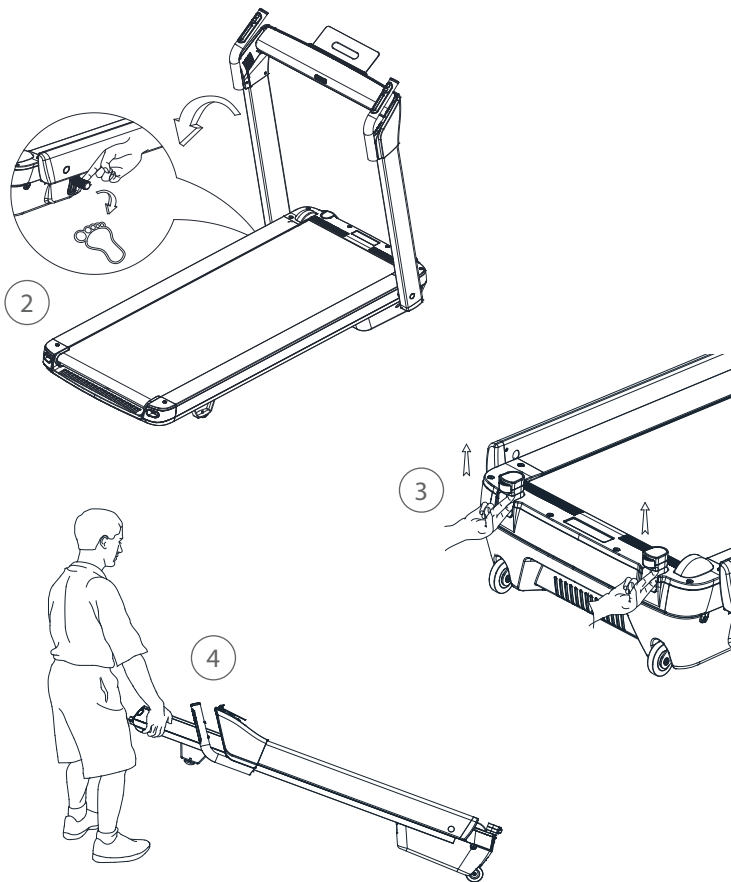

3.5 Use of the computer

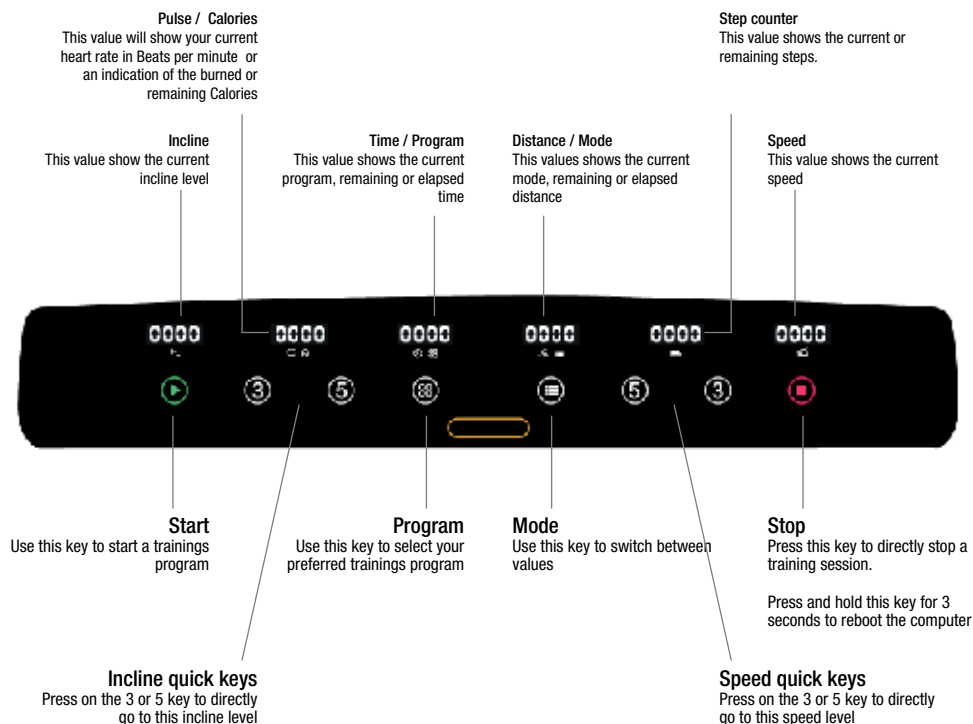

Standby

After 4 minutes of inactivity the computer will automatically turn into standby mode. Press one of the **SPEED** or **INCLINE** buttons to wake the computer from standby.

End a training session

During an exercise you are able to stop the training by pressing the **STOP** key on the computer or pulling out the safety key.

4. Use

Incline keys

With these keys you are able to change the incline level during a training exercise.

Within the menu these keys can be used to change the set target values.

Aux and USB

At the back of the computer there is an aux input that can be used for playing music over the treadmill's speakers. The USB port can only be used for charging your mobile devices as tablet and smartphones.

Speed Keys

With these keys you are able to change the speed level during a training exercise.

Within the menu these keys can be used to change the set target values.



Tablet holder

You are able to place your mobile device here while exercising. Please note, to fold away the tablet holder press the holder to the left first to unlock before folding it down.

Safety Key

Place the safety key into this holder and attach the clip on the other end of the rope to your clothing for safety reasons.

LED lighting en speakers

On both sides of the computer and near the tablet holder red ambient LED lights are fitted. The speakers are located at bot sides of the computer.

Manual Program

With the manual program you are able to set your preferable speed and incline level.

Manual - Quick start

Press the **START** key. The computer will countdown from 3 to zero. Then the computer will give a sound signal and the running belts starts turning at 1.0 KPH. You can start your training exercise. All values on the computer will increase.

Manual - Training with target value

With the manual program you are also able to set; time, speed or calories as a target value.

1. Press the **MODE** key once to set a target training duration. Press **MODE** twice to set a target distance or press **MODE** three times to set target calories. The selected value will flash on the computer. Use the **INCLINE ▲▼** or **SPEED ▲▼** keys to change the value. You only able to set one target value.
2. Press the **START** key to start the training session.

The training will start with the lowest speed and incline level. During the training session you are able to adjust the speed and incline level the speed and incline keys or quick keys. The training is finished when the set training value has been reached. The computer will give three sound signals before gradually slowing the running belt.

4. Use

Preset programs

There are 8 different preset programs. With the preset programs the speed and incline values will be changed automatically according to the programs profile. Below you can find an overview of the 8 different programs with speed and incline profile.

1. Select one of the 8 programs with the **PROGRAM** key. Press the program key until the

P1



P5



P2



P6



P3



P7

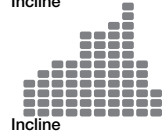

P4

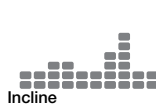

P8



desired program (P01-P08) appears on the screen.

2. Wait a few seconds or press the **MODE** key to set the desired training duration. The time value starts blinking at the default 30 minutes. Use the **INCLINE ▲▼** or **SPEED ▲▼** keys to change the time.

3. Press the **START** key to start the training session.

The duration of one segment (with according speed and incline level) will be determined by the set training duration. Before changing to the next segment the computer will give a sound as warning for a possible change in speed and / or incline level. During the training session you are able to modify the speed and / or incline for the current segment with the **INCLINE ▲▼** or **SPEED ▲▼** keys. The training is finished when the set duration has been elapsed. The computer will give three sound signals before gradually slowing the running belt.

User programs

You are able to make and save three user programs (U01-U03). Each user program is divided into 10 segments for which you can set the speed and incline level.

Make or change a user program:

1. Select the desired user program (U01-U03) with the **PROGRAM** key. The user programs are just after the preset programs (P01-P08) in the main menu.
2. Press the **MODE** key to set the speed and incline level of the first segment. Press the **SPEED ▲▼** keys to set the desired speed and press the **INCLINE ▲▼** keys to set the desired incline level.
3. Press the **MODE** key to go to the next segment and use the **INCLINE ▲▼**, **SPEED ▲▼** keys again to set the preferred speed and incline.
4. Repeat the previous step until all the 10 segments are set.
5. Now press the **MODE** key to set the training duration with the **INCLINE ▲▼** or **SPEED ▲▼** keys.
6. Press the **START** key to start your trainings session. Your user program will be saved automatically.

Start a saved user program:

1. Select the desired user program (U01-U03) with the **PROGRAM** key. The user programs are just after the preset programs (P01-P08) in the main menu.
2. Now wait a few seconds until the time value on the computer starts flashing at the default 30 minutes. Now set your preferred training time with the **INCLINE ▲▼**, **SPEED ▲▼** keys.
3. Press the **START** key to start your trainings session.

The duration of one segment (with according speed and incline level) will be determined by the set training duration. Before changing to the next segment the computer will give a sound as warning for a possible change in speed and / or incline level. During the training session you are able to modify the speed and / or incline for the current segment with the **INCLINE ▲▼** or **SPEED ▲▼** keys. The training is finished when the set duration has been elapsed. The computer will give three sound signals before gradually slowing the running belt.



3.6 Connect the Fitshow app

Operate your Runner DTM400i treadmill with your mobile device through the FitShow app. Control a manual program in the app, run your favorite route with street view, set fitness goals and log your results.

Download the FitShow app by searching 'iFitShow' in the Apple iOS App store or search for 'FitShow' in the Google Android Play store. You can also follow one of the links below

Apple iOS App store

<https://itunes.apple.com/US/app/id1099080595?mt=8>

Google Android Play Store

<https://play.google.com/store/apps/details?id=com.fitshow&hl=en>

4. Use

3.7 Maintenance

Maintaining the sliding surface

Every 1 or 2 months (even if the treadmill is not in use) or every 50 hours of use, the sliding surface under the running deck needs to be lubricated with the included silicone lubricant. Make sure that the power is disconnected and loosen the adjusting bolts of the rear roller. Lubricate the surface, distribute the silicone lubricant evenly. When you are finished fastening the adjustment bolts of the rear roller. Center the treadmill again as described on the next page

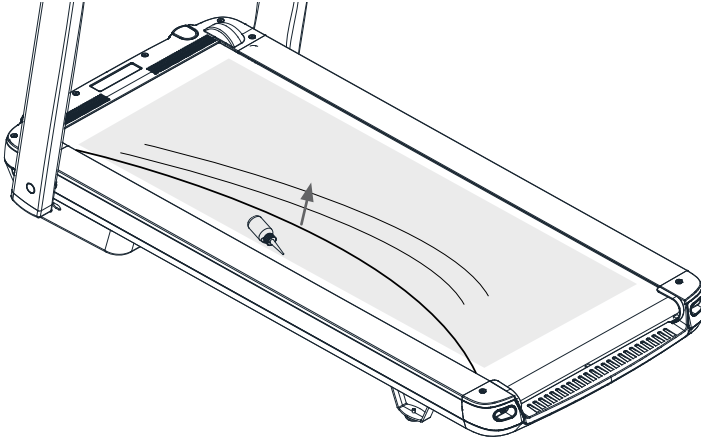

Cleaning

The metal and plastic parts of the product can be cleaned by using standard cleaning products. However, make sure that all parts are completely dry before they are used again.

Flow Fitness advises to fasten nuts and bolts, check and fasten pivot points once every six weeks. For fastening use the tool supplied with the product.

To prevent unnecessary wear, the product can only be used indoors and in a dry environment.

Centring and tensioning the belt

Within the first weeks of using the treadmill, it is possible that you need to centre the belt. For example this can happen when applying more pressure to the left foot over your right.

Make sure the treadmill is running with a speed between 3 and 5 KPH. At the back of the frame there are two adjustment bolts. These bolts allow you to adjust the rear roller. When the treadmill is running to the left, you need to turn the left adjusting bolt clockwise on the and the right adjustment bolt counter clockwise. In the event that the treadmill is right, you have to turn the left adjustment bolt counter-clockwise and the right adjustment screw clockwise. Make sure the belt stays well tensioned and is not waving.

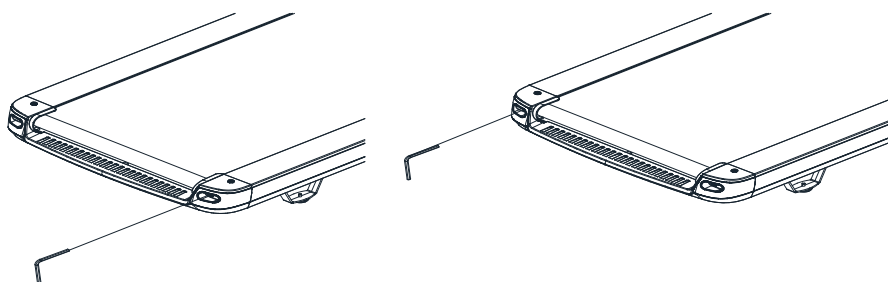

4. General information

4.1 Training schedule

Introduction schedule

Schedule week 1 and 2

Train at 60% of your maximum heart rate.
Max. 3 times a week.

Warming up 5 - 10 minutes.

Train 4 minutes.

Rest 1 minute.

Train 2 minutes.

Calmly train 1 minute.

Cooling down 5 minutes.

Schedule week 3 and 4

Train at 60% of your maximum heart rate.
Max. 4 times a week.

Warming up 5 - 10 minutes.

Train 5 minutes.

Rest 1 minute.

Train 3 minutes.

Calmly train 1 minute.

Cooling down 5 minutes.

Schedule week 5 and 6

Train at 60% of your maximum heart rate.
Max. 5 times a week.

Warming up 5 - 10 minutes.

Train 6 minutes.

Rest 1 minute.

Train 4 minutes.

Calmly train 3 minutes.

Cooling down 5 minutes.

After completing the introduction training schedule for six weeks, you can choose the follow-up training schedule that is best suited to your needs. You can choose a schedule that will maximize your weight loss, or one that will improve your stamina. Both training schedules are on the next pages.

Training schedule to improve stamina (follow-up to introduction training schedule)

Schedule week 7 and 8

Train at 80% of your maximum heart rate.
Max. 6 times a week.

Warming up 5 - 10 minutes.

Train 7 minutes.

Rest 1 minute.

Train 5 minutes.

Calmly train 1 minute.

Cooling down 5 minutes.

Schedule week 9 and beyond

Train at 80% of your maximum heart rate.
Max. 6 times a week.

Warming up 5 - 10 minutes.

Train 10 minutes.

Rest 1 minute.

Train 10 minutes.

Repeat training 2 or 3 times.

Calmly train 1 minute.

Cooling down 5 minutes.

Training schedule to lose weight (follow-up to introduction training schedule)

Schedule week 7 and 8

Train at 60% of your maximum heart rate.
Max. 6 times a week.

Warming up 5 - 10 minutes.

Train 7 minutes.

Rest 1 minute.

Train 5 minutes.

Calmly train 1 minute.

Cooling down 5 minutes.

Schedule week 9 and beyond

Train at 60% of your maximum heart rate.
Max. 6 times a week.

Warming up 5 - 10 minutes.

Train 10 minutes.

Rest 1 minute.

Train 10 minutes.

Repeat training 2 or 3 times.

Calmly train 1 minute.

Cooling down 5 minutes.

5. General information

4.2 Exploded view

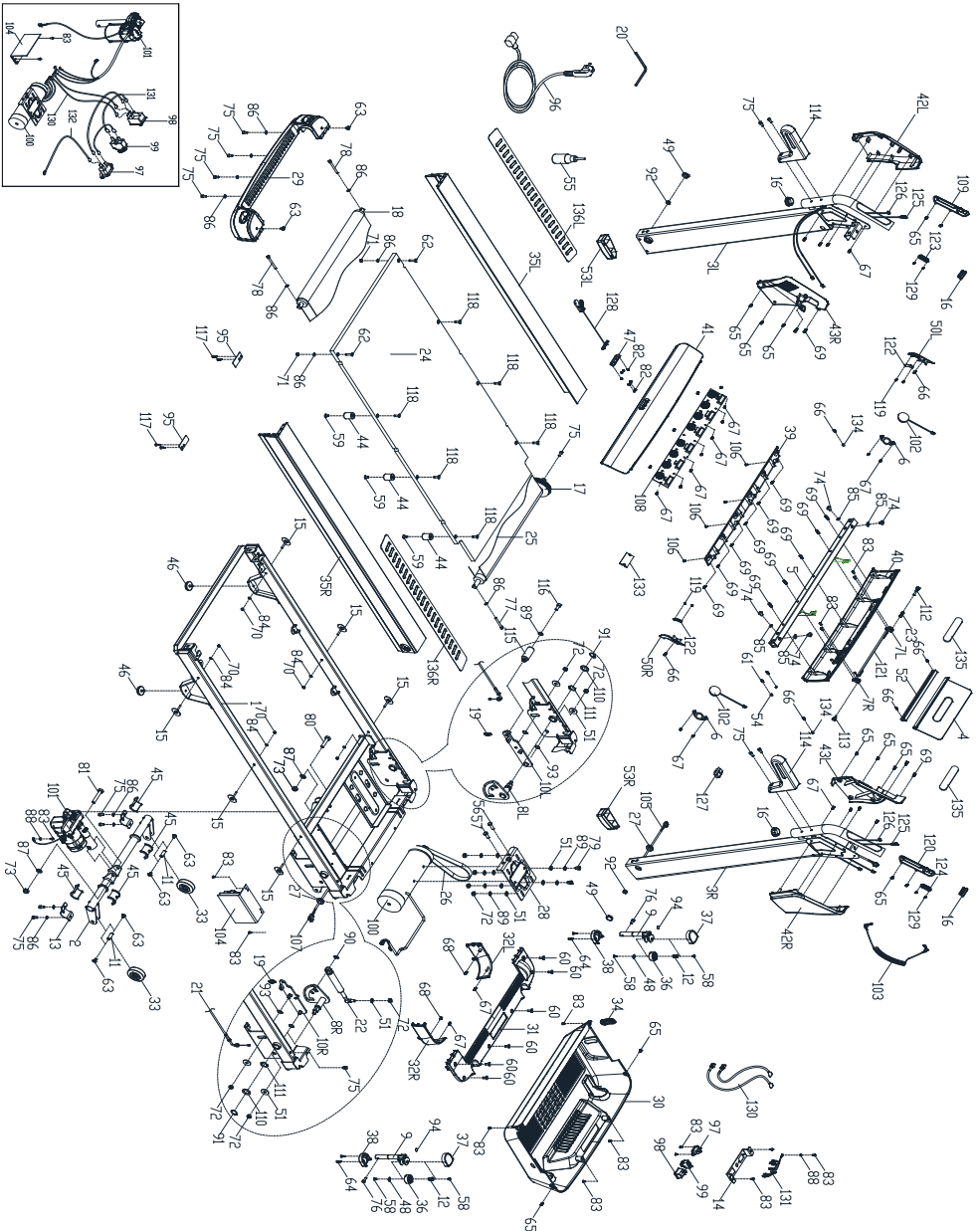

5. General information

No.	Part	QTY	No.	Part	QTY
1	Main frame	1	70	nut M5	6
2	Incline bracket	1	71	nut M6	2
3L/R	Upright	2	72	nut M8	11
4	Tablet holder	1	73	nut M10	2
5	Computer bracket horizontal tube	1	74	screw M8*15	6
6	Loudspeaker fixed seat	2	75	screw M6*12 nyloc	12
7L/R	pad bracket fixed seat	2	76	screw M6*15 half-thread nyloc	2
8L/R	Adjusting sheet L/R	2	77	screw M6*50	1
9	Supporting wheel fixed bracket	2	78	screw M6*60	2
10L/R	Choice sheet L/R	2	79	screw M8*12	2
11	Transporting wheel axis	2	80	Bolt M10*45 10.9 grade screw L15mm	1
12	Supporting wheel axis	2	81	bolt M10*60 10.9 grade Screw L15mm	1
13	Incline bracket U shape fixed seat	2	82	screw M2*5	6
14	Power fixed connector	1	83	screw M4*8 1	6
15	Edging buckle	6	84	washer 5*12*1.2	6
16	Handrail stopple	4	85	Flat washer 9*16*t1.6	4
17	Font roller	1	86	washer 6.6*11.8*t1.6	13
18	Rear roller	1	87	Flat washer 11*20*t2.0	2
19	extension spring	2	88	washer 4.1*4.4*t1	2
20	Wrench 5#	1	89	Spring washer M8	7
21	cabie	1	90	E-ring 8 black	1
22	cylinder	1	91	C-ring match 20 black shaft	2
23	compression spring	1	92	Flange nut M10*P1.25	2
24	Running board	1	93	Flat washer 12.2*17*t0.5	4
25	Running belt	1	94	O shape ring D13*1.5	2
26	Multi-groove belt	1	95	Running board baffle	2
27	Ring wire plug	2	96	Power cord	1
28	Motor seat	1	97	End socket	1
29	Rear cover	1	98	Power switch	1
30	Motor under cover	1	99	Overload protector	1
31	Upper motor cover	1	100	DC motor	1
32L/R	Motor cover Left/right decorative cap	2	101	Incline motor	1
33	Transporting wheel	2	102	loudspeaker	2
34	Foot lever	1	103	Mp3 AUX line	1
35L/R	Side rail L/R	2	104	MCB	1
36	Supporting transporting wheel	2	105	upper wire	1
37	Supporting wheel upper cover	2	106	screw M4*12	4
38	Supporting wheel under cover	2	107	Lower wire	1
39	Computer under cover	1	108	Computer PCB	1
40	Computer under cover	1	109	Incline shortcut key seat	1
41	Computer panel	1	110	washer 20.5*30*t2.0	2
42L/R	Computer left/right outer side cover	2	111	wave shape washer 20.5*27*t0.4	2
43L/R	Computer left inner side cover	2	112	Pad bracket fixing screw left	1
44	cushion	6	113	Pad bracket fixed screw right	1
45	Incline axle sleeve	4	114	handrail	2
46	Bracket adjusting foot pad	2	115	Foot lever	1
47	Safety lock seat	1	116	screw M8*35	1
48	C-shape Snap Rings 10	2	117	screw M4*12	4
49	Upright stopple	2	118	screw M6*25	6
50L/R	Loudspeaker light shade left/right	2	119	screw BT2.2*5 nickle-plating	4
51	Flat washer 9*23*t1.5	11	120	speed shortcut key seat	1
52	Light transmitting plate	1	121	Pad decorating light	1
53L/R	Left right upright stopple	2	122	Loudspeaker decorating light	2
54	module fixer	2	123	Incline shortcut key PC	1
55	Silicon oil	1	124	Speed shortcut key PC	1
56	bolt M8*20	1	125	Pulse outgoing line	2
57	bolt M8*25	1	126	Shortcut key outgoing wire	2
58	screw M5*8	4	127	USB module	1
59	screw M6*12	8	128	Safety Key	1
60	screw M6*20	6	129	screw M3*6	4
61	screw ST3.0*15	2	130	Single wire 500mm	2
62	screw M6*28	2	131	Single wire 350mm	3
63	screw M6*12	4	132	Grounding wire200mm	1
64	screw ST3.0*20	4	133	Bluetooth module	1
65	screw ST4.0*15	12	134	Pole pressing seat	2
66	screw BT2.5*8	6	135	M7 pad Single-sided adhesive	2
67	screw ST3.0*10	25	136	anti-slip sticker left/right	2
68	screw BT4*8	2	137	Screw cover	2
69	screw BT4*15	15			

5. General information

4.3 Troubleshooting

Problem	The computer of the treadmill is not switching on.
Solution	<ol style="list-style-type: none">1. Check if the plug is connected to a grounded outlet2. Check if the switch near the adapter cable is set to ON or I.3. Check if the fuse near the switch . If the fuse is broken contact your reseller.
Problem	Segments of the screen don't light up.
Solution	The screen LED are damaged, contact your reseller.
Problem	The screen shows "SAFE".
Solution	The safety key is not placed (correctly). Place the safety key into the designated area of the treadmill.
Problem	My iOS or Android device is not connecting to the DTM400i.
Solution	<ol style="list-style-type: none">1. Turn off any app used for connecting to the DTM400i.2. Turn off the treadmill with the 1/0 switch. Wait 5 seconds, and turn the treadmill back on again.3. Enter the bluetooth settings menu of your mobile device. Choose the option "Forget this device" and turn off the bluetooth4. Repeat the bluetooth connection steps described in this manual. <p>In case your problem is not resolved or not described, consult the fitness reseller where you purchased this product.</p>

5.1 Warranty

The warranty is provided by the Flow Fitness distributor of your country and the reseller where you have purchased your product. Please check

<https://www.flowfitness.com/en/dealers/>

for contact information.

DECLARATION OF THE MANUFACTURER

Flow Fitness hereby declares that this product complies with the following standards and directives:

- EN ISO 20957
- EMC Directive (2014/30/EU)
- Low Voltage Directive (2014/35/EU)
- Radio Equipment Directive (2014/53/EU)
- RoHS Directive (2011/65/EU and 2015/863)

As a result of compliance with the above standards and directives, this product is CE certified.

FLOW FITNESS

Jan Tinbergenstraat 131
7559 SP Hengelo
The Netherlands

