



IN220901222V03_GL

B72-035



MAX:150KG

EN_IMPORTANT, RETAIN FOR FUTURE REFERENCE: READ CAREFULLY.

FR_IMPORTANT: A LIRE ATTENTIVEMENT ET A CONSERVER POUR VOUS Y REFRERER ULTERIEUREMENT

ES_IMPORTANTE, LEA DETENIDAMENTE Y GUARDE PARA FUTURAS REFERENCIAS.

PT_IMPORTANTE, GUARDE PARA FUTURA REFERÊNCIA, LEIA ATENTAMENTE.

DE_WICHTIG! SORFGFÄLTIG LESEN UND FÜR SPÄTERES NACHSCHLAGEN AUFBEWAHREN.

IT_IMPORTANTE, LEGGERE E CONSERVARE QUESTO MANUALE D'ISTRUZIONE PER UN USO FUTURO.

HINGE: Change your ladder's shape.

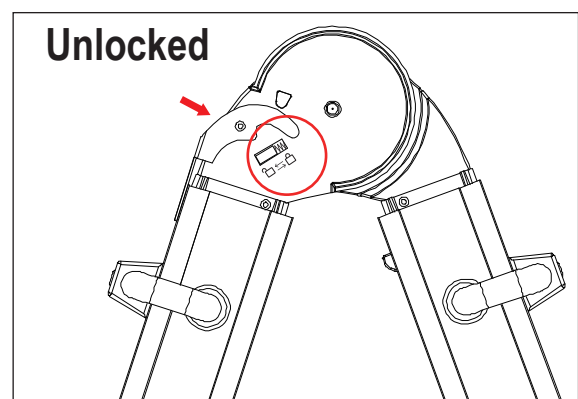
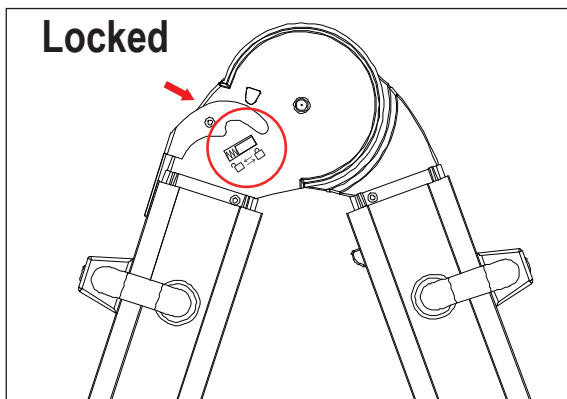

Use your fingers to pull the locking buckle on both sides of the ladder's hinges.

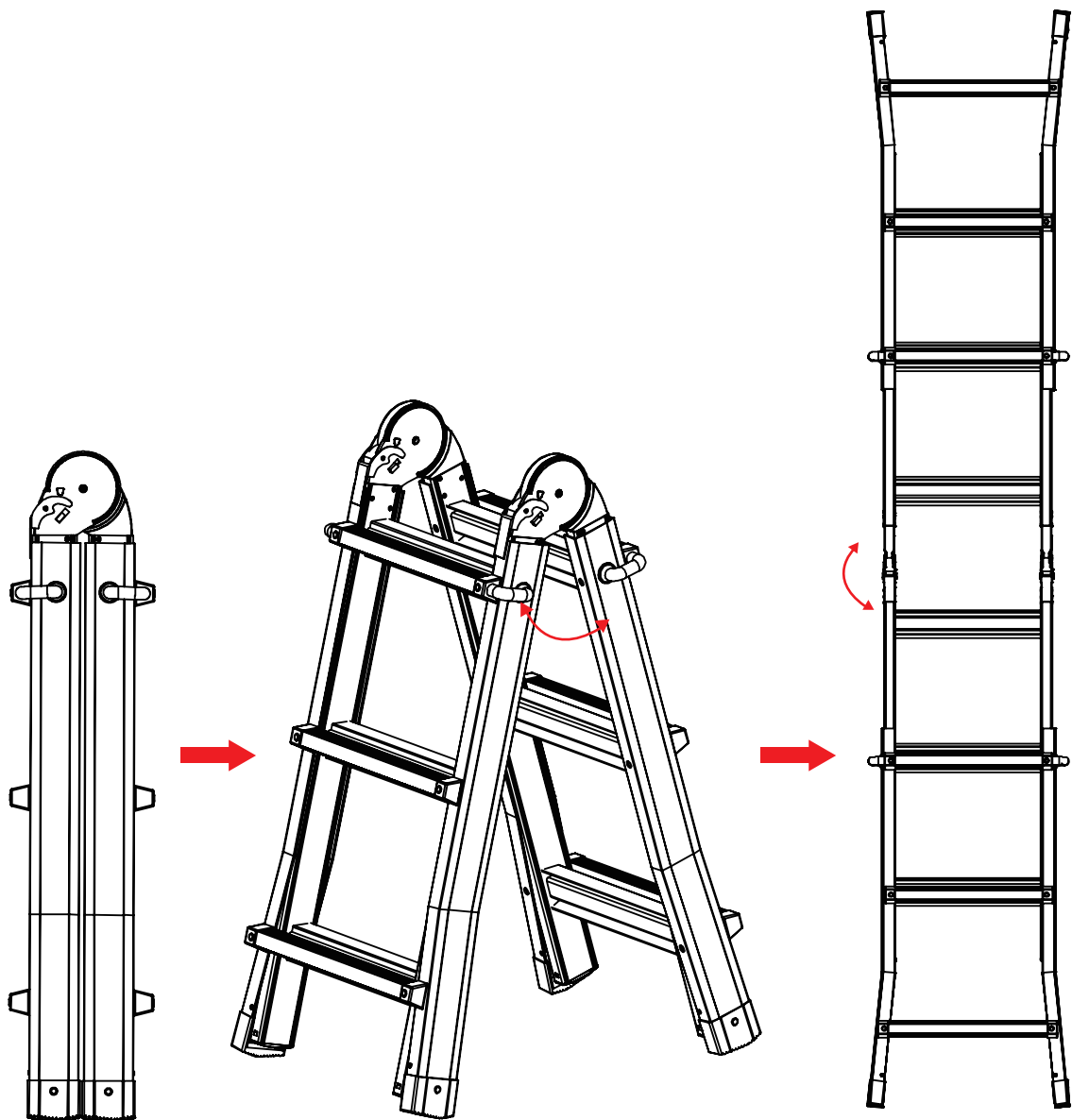

The hinges allow the ladder to transition between storage, A-frame and extension configurations.

“J” LOCK: Change your ladder’s height.

Locked

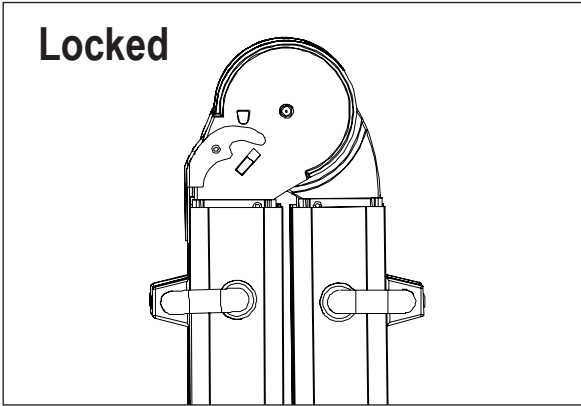

Unlocked

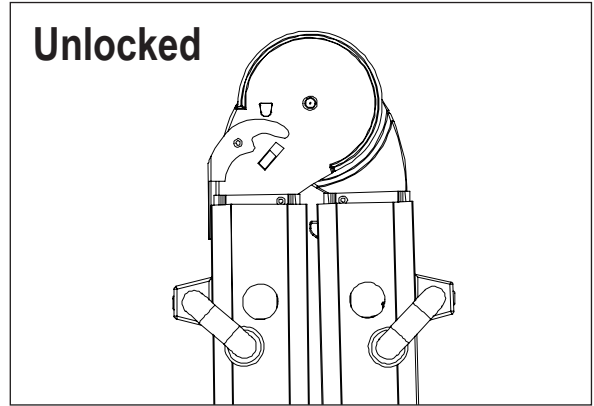

To adjust the height, follow these steps:

- Unlock the ladder by pulling out the spring-loaded 'J' lock.
- Extend the ladder side rail to your desired height.
- Twist and align the 'J' lock into the rung hole until it is fully engaged.

Important: Do not unlock the 'J' lock if someone is on the ladder.

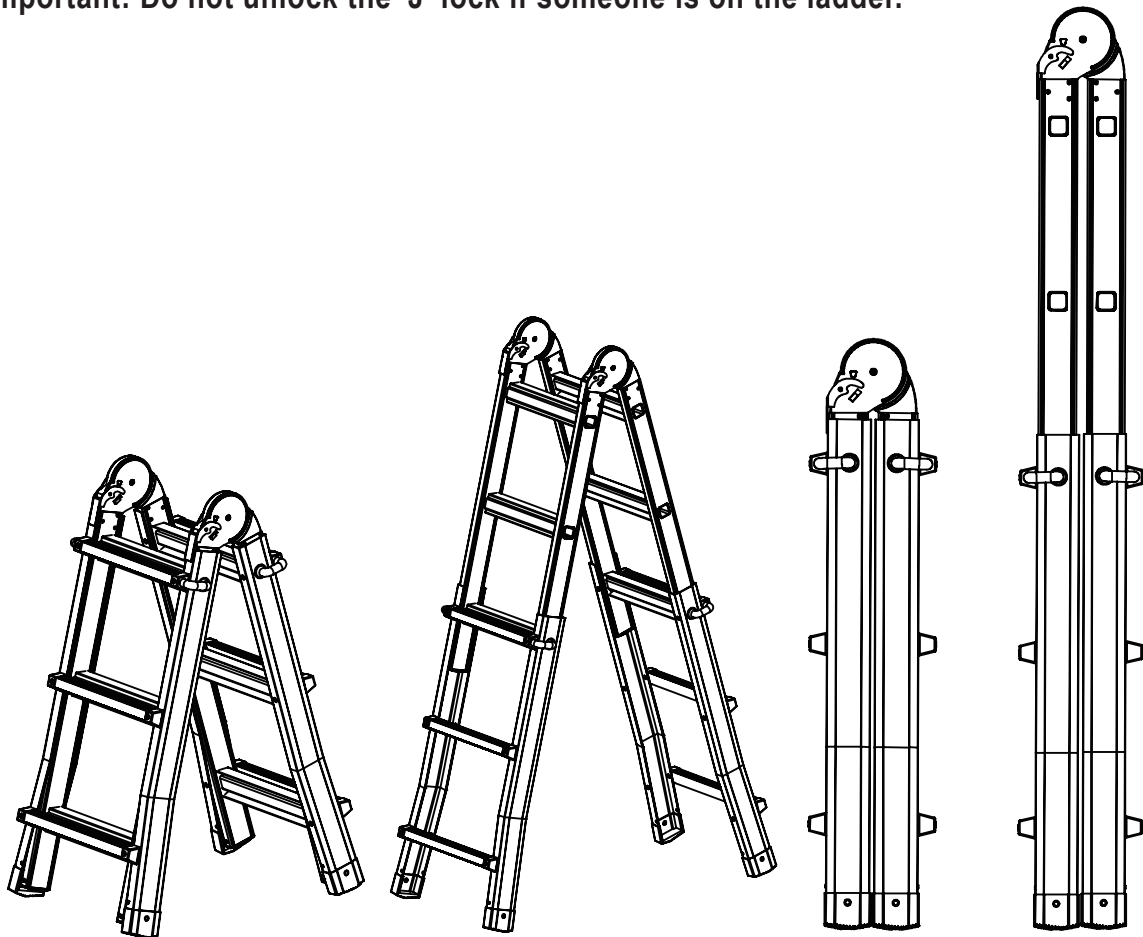

Adjust the desired height.

PRODUCT OVERVIEW

A versatile ladder that can be adjusted into various positions and heights. It is made up of three sections and has two different locking mechanisms.

LADDER CONFIGURATIONS

The ladder has two locking hinges on each side and two spring-loaded locks on the outer sections. These hinges enable the ladder to be used in four different configurations, including extension ladder, stepladder, stairway ladder and scaffold mode. In all these configurations, except for scaffold mode, you can adjust the height to suit your needs.

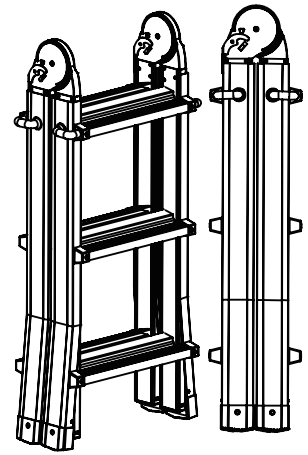

A Frame Ladder

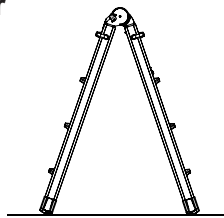

- NEVER stand in between the front and back sections(straddling).
- NEVER stand on or above the second rung from the top.

Extension Ladder



- NEVER stand on the top three rungs.
- Ensure the ladder's angle is approximately 75 degrees.



Only use this ladder in the positions shown above. Any other position, which is not shown in this manual, can result in serious injury or death.

DO NOT exceed the maximum load of this ladder. Refer to labels on the ladder.

CHARNIÈRE : Pour changer la forme de l'échelle

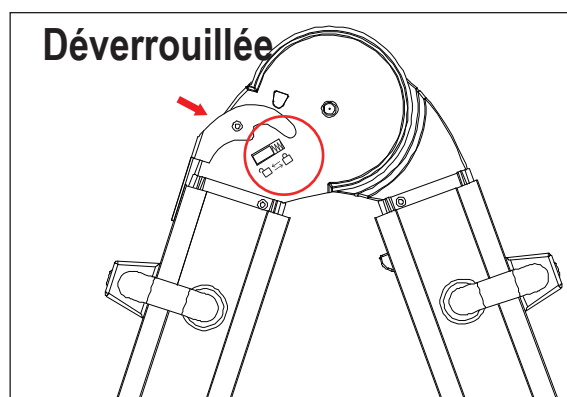
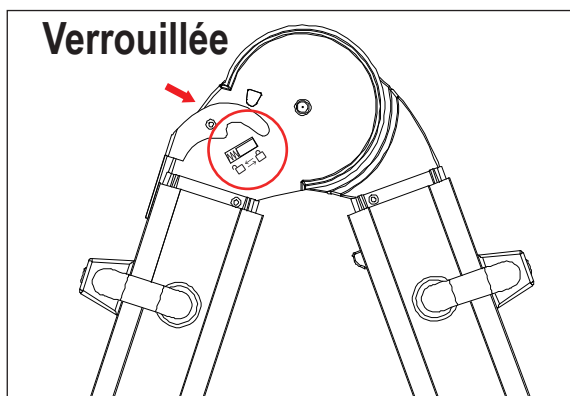

Tirez avec les doigts sur la boucle de verrouillage située de part et d'autre des charnières de l'échelle.

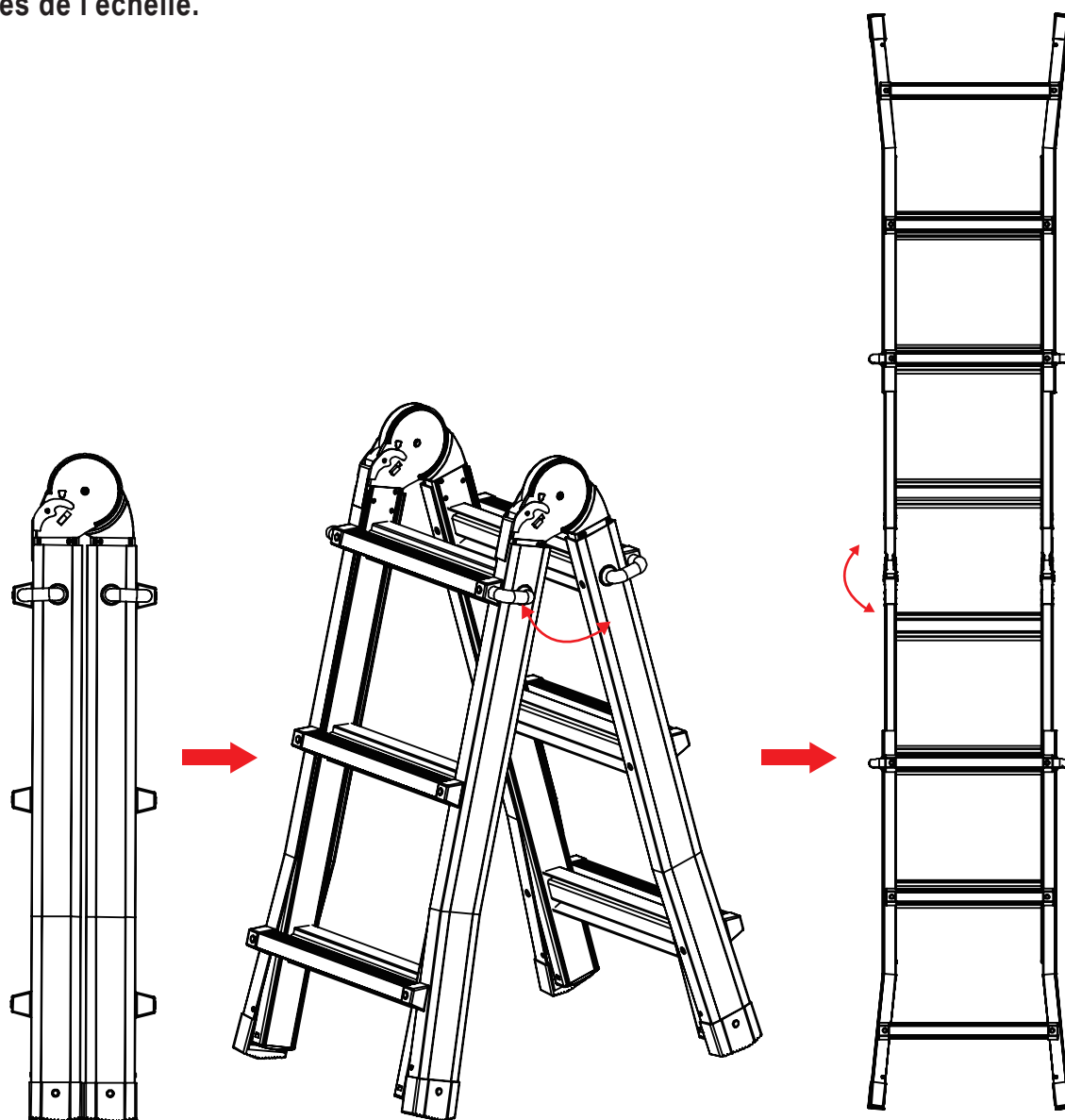

Les charnières permettent de faire passer l'échelle d'une configuration de rangement à une configuration en A ou en extension.

VERROUILLAGE 'J' :

Pour ajuster la hauteur de l'échelle.

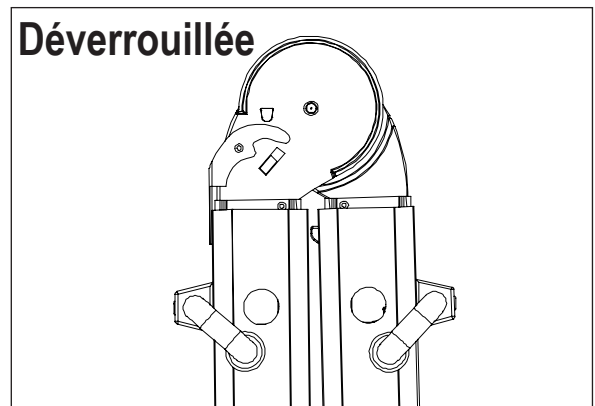
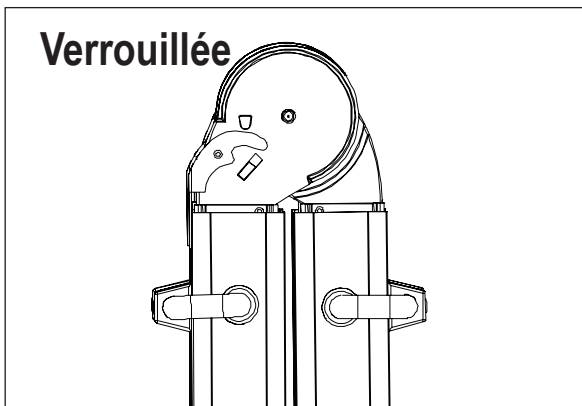

Pour ajuster la hauteur, procédez comme suit :

- Déverrouillez l'échelle en tirant sur le verrou 'J' à ressort.
- Déployez le montant latéral de l'échelle à la hauteur désirée.
- Tournez et alignez le verrou 'J' dans le trou de l'échelon jusqu'à ce qu'il soit complètement engagé. Important : Ne déverrouillez pas le verrou 'J' si quelqu'un se trouve sur l'échelle.

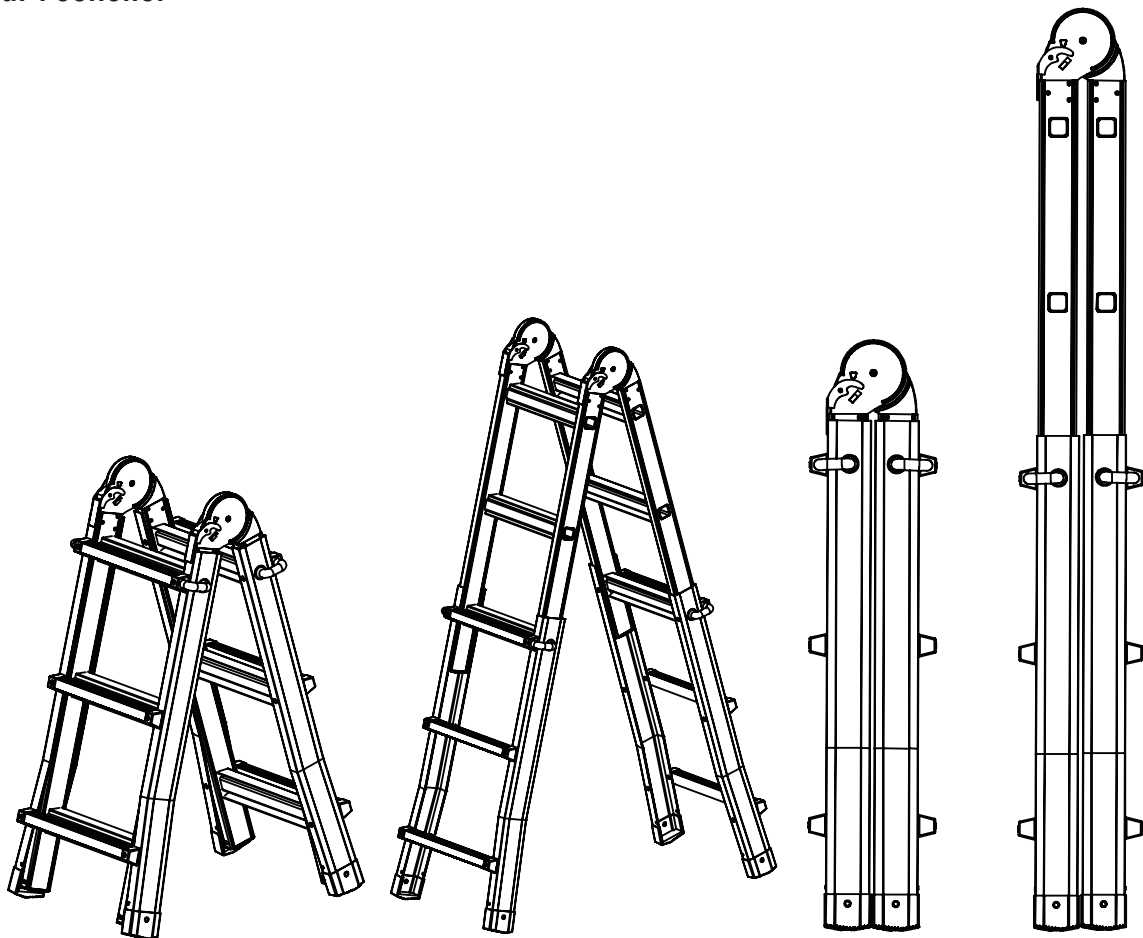

Ajustez la hauteur

DESCRIPTION DU PRODUIT

Une échelle polyvalente pouvant être ajustée dans différentes positions et hauteurs. Elle est composée de trois sections et possède deux mécanismes de verrouillage différents.

CONFIGURATIONS DE L'ÉCHELLE

L'échelle possède deux charnières de verrouillage de chaque côté et deux verrous à ressort sur les sections extérieures. Ces charnières permettent à l'échelle d'être utilisée dans quatre configurations différentes, notamment en mode extension, en mode marche, en mode escalier et en mode échafaudage. Dans toutes ces configurations, sauf en mode échafaudage, vous pouvez ajuster la hauteur selon vos besoins.

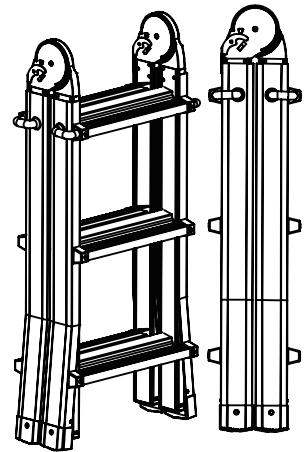

Échelle en forme de A

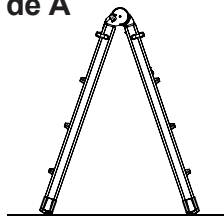

- Ne vous tenez **JAMAIS** entre les sections avant et arrière.

- Ne vous tenez **JAMAIS** sur ou au-dessus du deuxième échelon en partant du haut.

Échelle en extension



- Ne vous tenez **JAMAIS** entre les sections avant et arrière.

- Assurez-vous que l'angle de l'échelle est d'environ 75 degrés.



Utilisez uniquement cette échelle dans les positions indiquées ci-dessus. Toute autre position, non présentée dans ce manuel, peut entraîner des blessures graves ou des dangers de mort.

NE DÉPASSEZ PAS la charge maximale de cette échelle. Reportez-vous aux étiquettes apposées sur l'échelle.

BISAGRA: Cambia la forma de la escalera

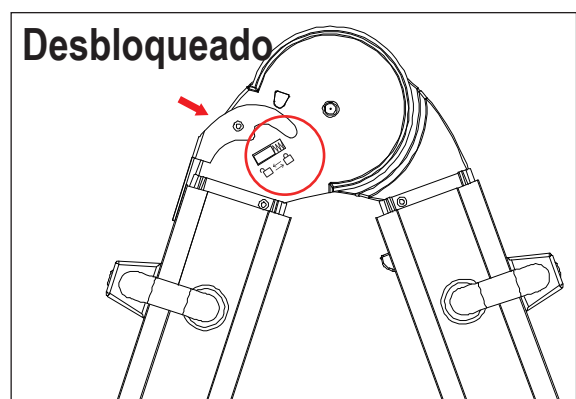
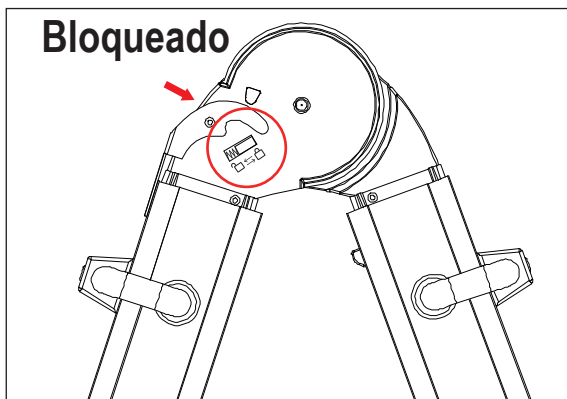

Usa tus dedos para tirar de la hebilla de bloqueo en ambos lados de las bisagras de la escalera.

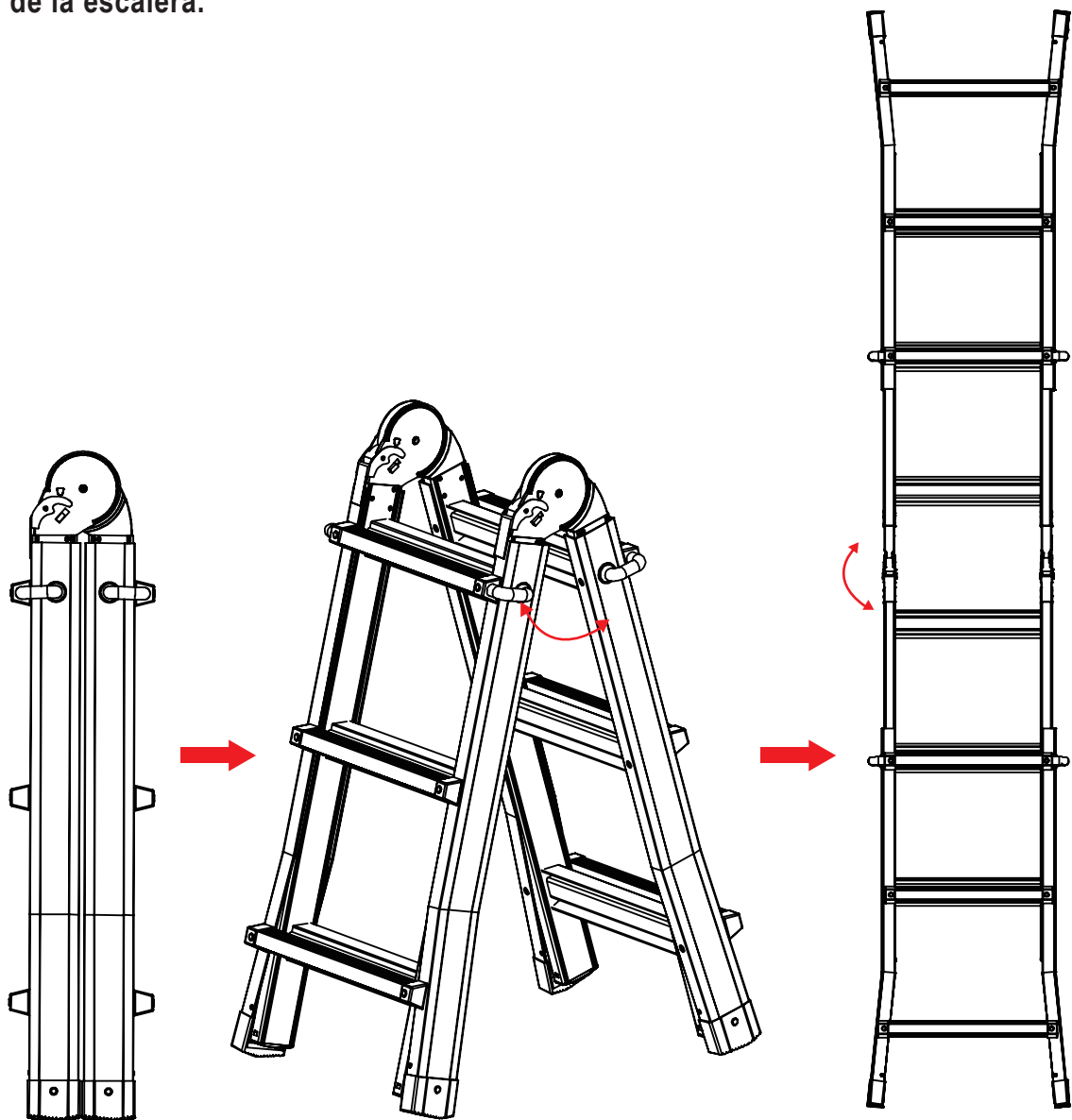

Las bisagras permiten que la escalera cambie entre las configuraciones de almacenamiento, en forma de A y de extensión

CIERRE 'J'

: Cambia la altura de la escalera

Bloqueado

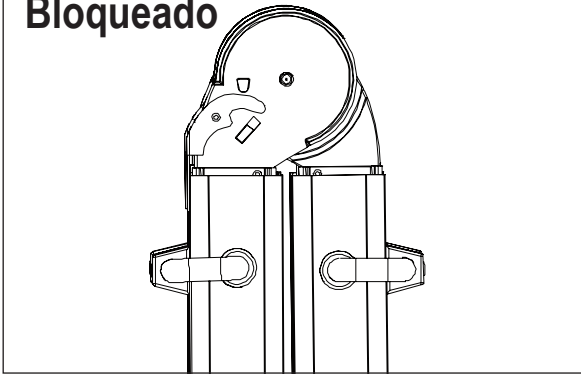

Desbloqueado

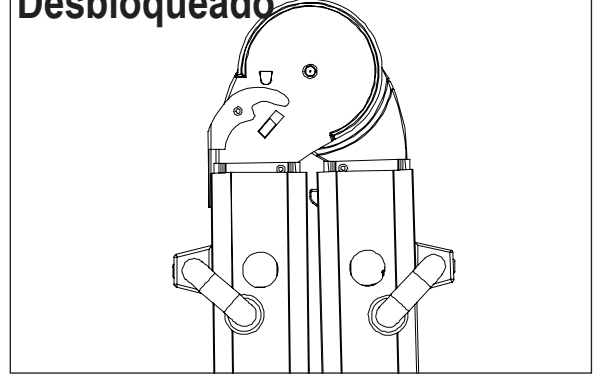

Para ajustar la altura, sigue estos pasos:

- Desbloquea la escalera tirando hacia afuera del cierre 'J' con resorte.
- Extiende el riel lateral de la escalera hasta la altura deseada.
- Gira y alinea el cierre 'J' en el agujero del peldaño hasta que esté completamente encajado.

Importante: No desbloquee el cierre 'J' si alguien está en la escalera.

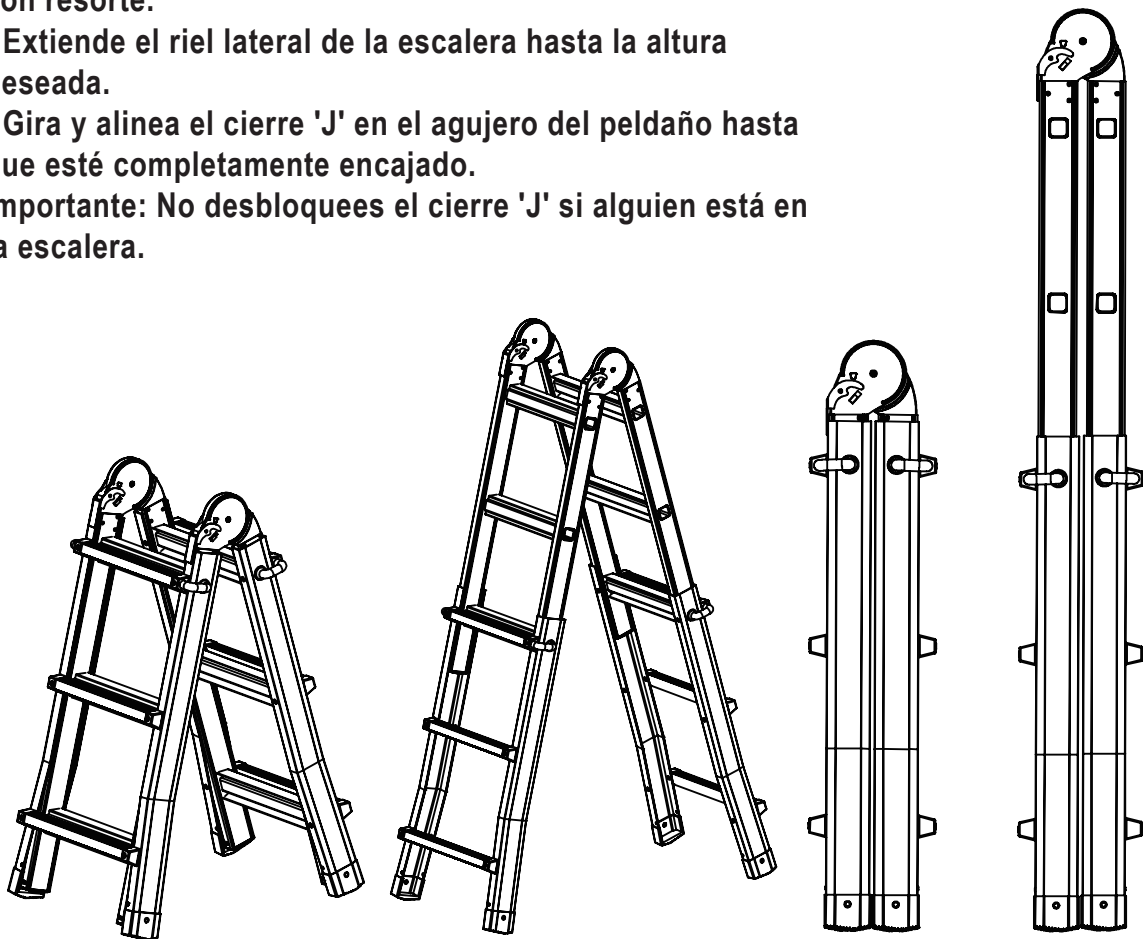

Ajusta la altura

DESCRIPCIÓN DEL PRODUCTO

Una escalera versátil que se puede ajustar en varias posiciones y alturas. Está compuesta por tres secciones y cuenta con dos mecanismos de bloqueo diferentes.

CONFIGURACIONES DE LA ESCALERA

La escalera cuenta con dos bisagras de bloqueo en cada lado y dos cerraduras de resorte en las secciones exteriores. Estas bisagras permiten que la escalera se utilice en cuatro configuraciones diferentes, incluyendo escalera de extensión, escalera de tijera, escalera de escalera y modo andamio. En todas estas configuraciones, excepto en el modo andamio, puedes ajustar la altura según tus necesidades.

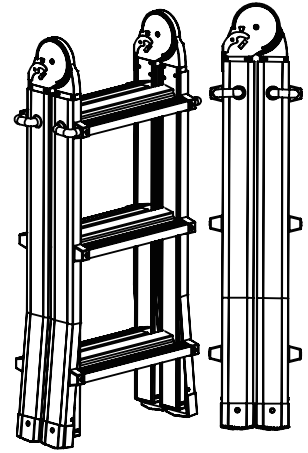

Escalera en forma de A

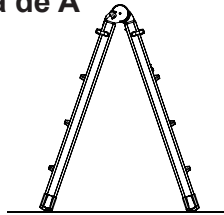

- NUNCA te pongas entre las secciones delanteras y traseras.
- NUNCA te pongas de pie en la segunda peldaño desde arriba o por encima.

Escalera de extensión



- NUNCA te pongas de pie en los tres peldaños superiores.
- Asegúrate de que el ángulo de la escalera sea aproximadamente de 75 grados.



Solo utiliza esta escalera en las posiciones mostradas anteriormente. Cualquier otra posición que no esté indicada en este manual puede resultar en lesiones graves o la muerte. NO excedas la carga máxima de esta escalera. Consulta las etiquetas en la escalera.

DOBRADIÇA: Alterar a forma da escada

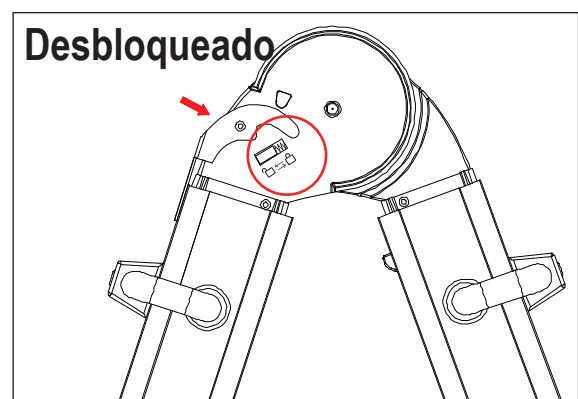
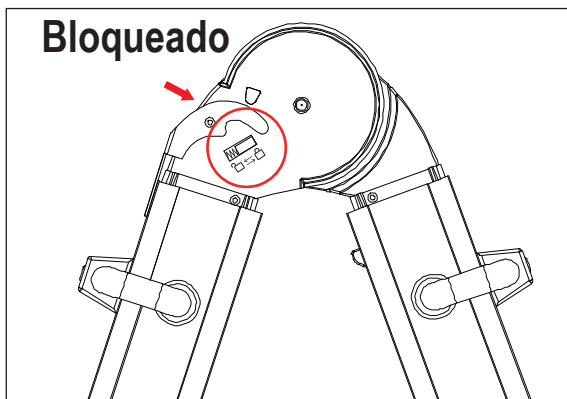

Utilize os dedos para puxar a fivela de travamento em ambos os lados das dobradiças da escada.

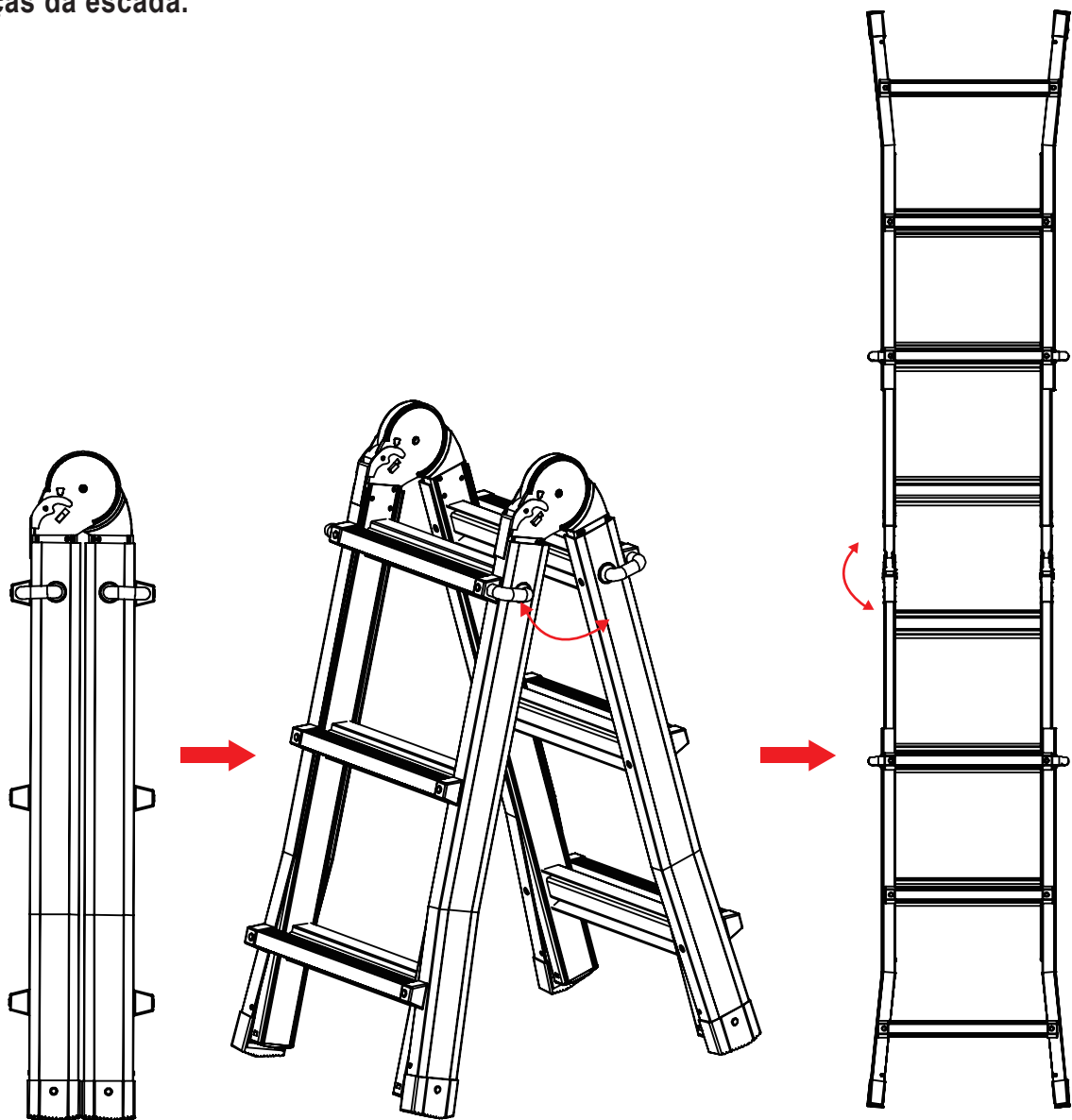

As dobradiças permitem que a escada altere entre as configurações de arrumação, de estrutura em A e de extensão.

" BLOQUEIO": Alterar a altura da escada.

Bloqueado

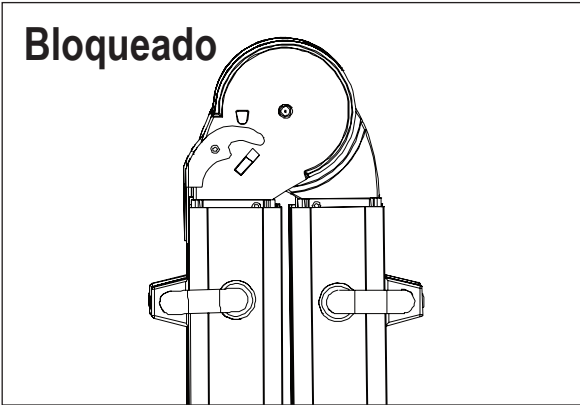

Desbloqueado

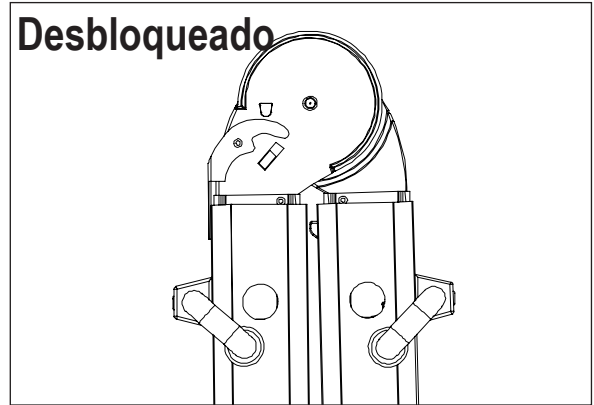

Para ajustar a altura, siga estes passos:

- Desbloquear a escada puxando o fecho "J" com mola.
- Estender a estrutura da escada até à altura pretendida.
- Rodar e alinhar o fecho em "J" no orifício até estar totalmente engatado.

Importante: Não desbloqueie o fecho "J" se estiver alguém na escada.

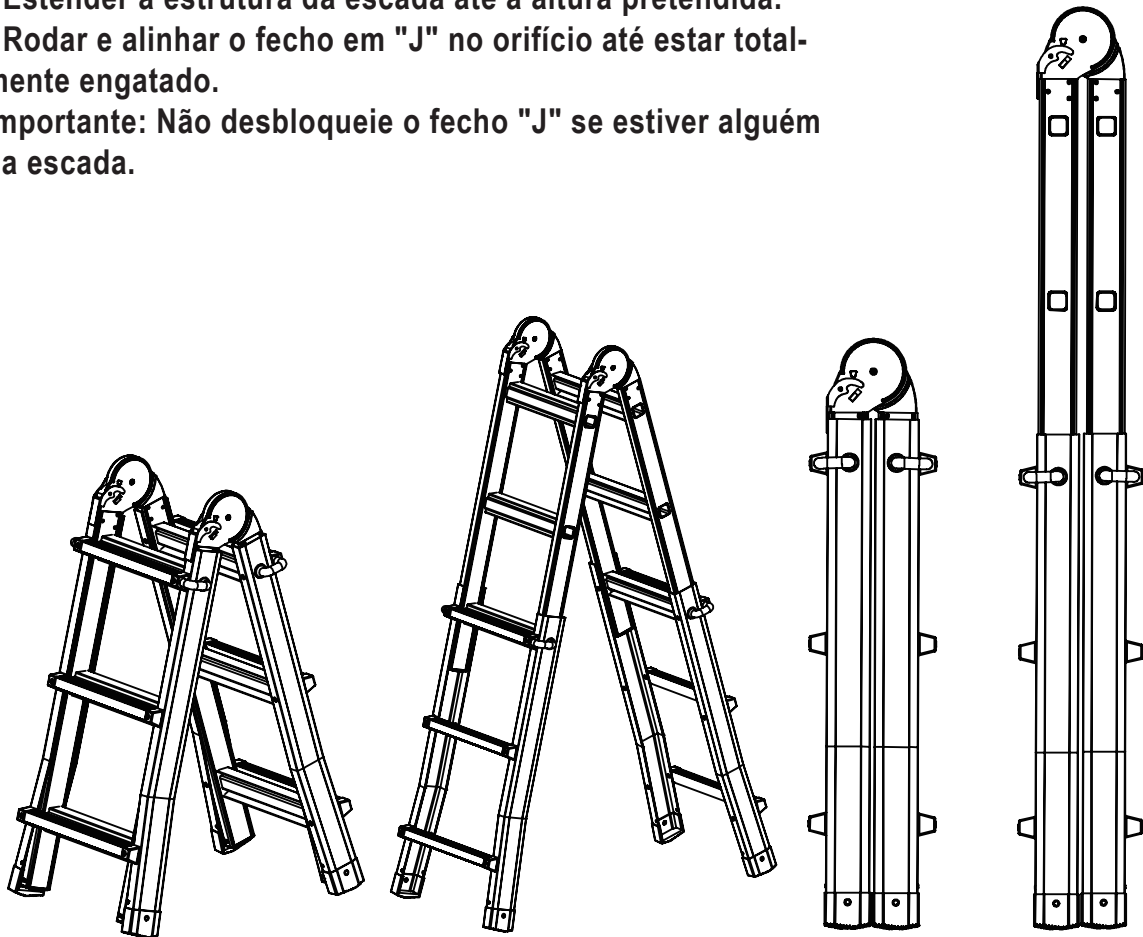

Ajustar a altura

VISÃO GERAL DO PRODUTO

Esta escada versátil pode ser ajustada em várias posições e alturas. É composta por três seções e tem dois mecanismos de fecho diferentes.

CONFIGURAÇÕES DE ESCADAS

A escada tem duas dobradiças de bloqueio de cada lado e dois fechos de mola nas seções exteriores. Estas dobradiças permitem utilizar a escada em quatro configurações diferentes, incluindo escada extensível, escada, escada de mão e andaime. Em todas estas configurações, exceto no modo andaime, é possível regular a altura para adaptar-se às suas necessidades.

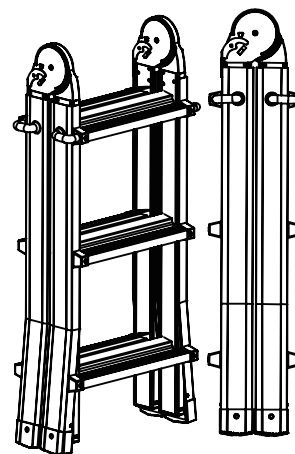

Escada em A

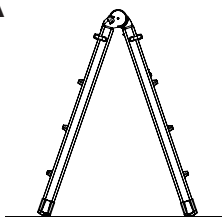

- NUNCA se coloque entre a parte da frente e traseira.

- NUNCA se coloque sobre ou acima do segundo degrau a partir do topo.

Escada extensível



- NUNCA ficar nos três primeiros degraus.

- Assegurar que o ângulo da escada é aproximadamente 75 graus.



Utilizar esta escada apenas nas posições indicadas acima. Qualquer outra posição, que não seja apresentada neste manual, pode resultar em ferimentos graves ou morte.

NÃO exceda a carga máxima desta escada. Consulte as etiquetas na escada.

SCHARNIER: Ändern Sie die Form Ihrer Leiter.

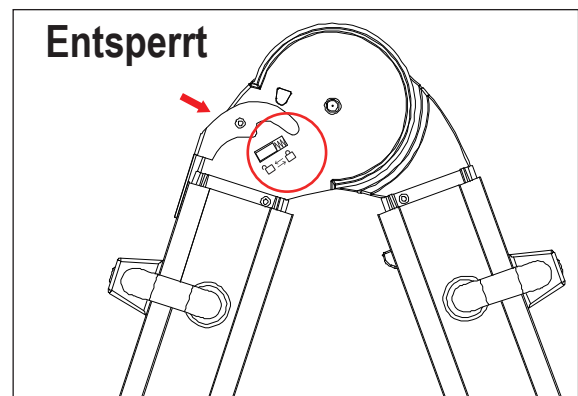
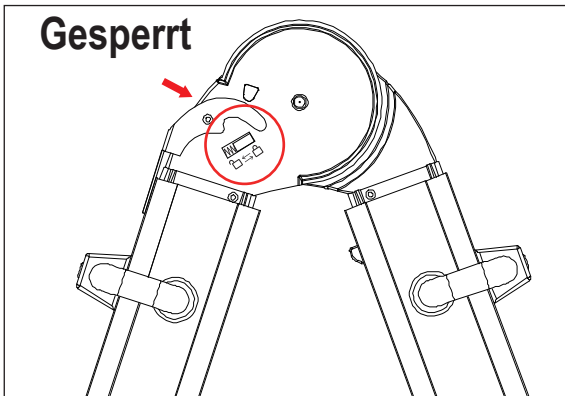

Verwenden Sie Ihre Finger, um die Verriegelungsschnalle auf beiden Seiten der Leiter-Scharniere zu ziehen.

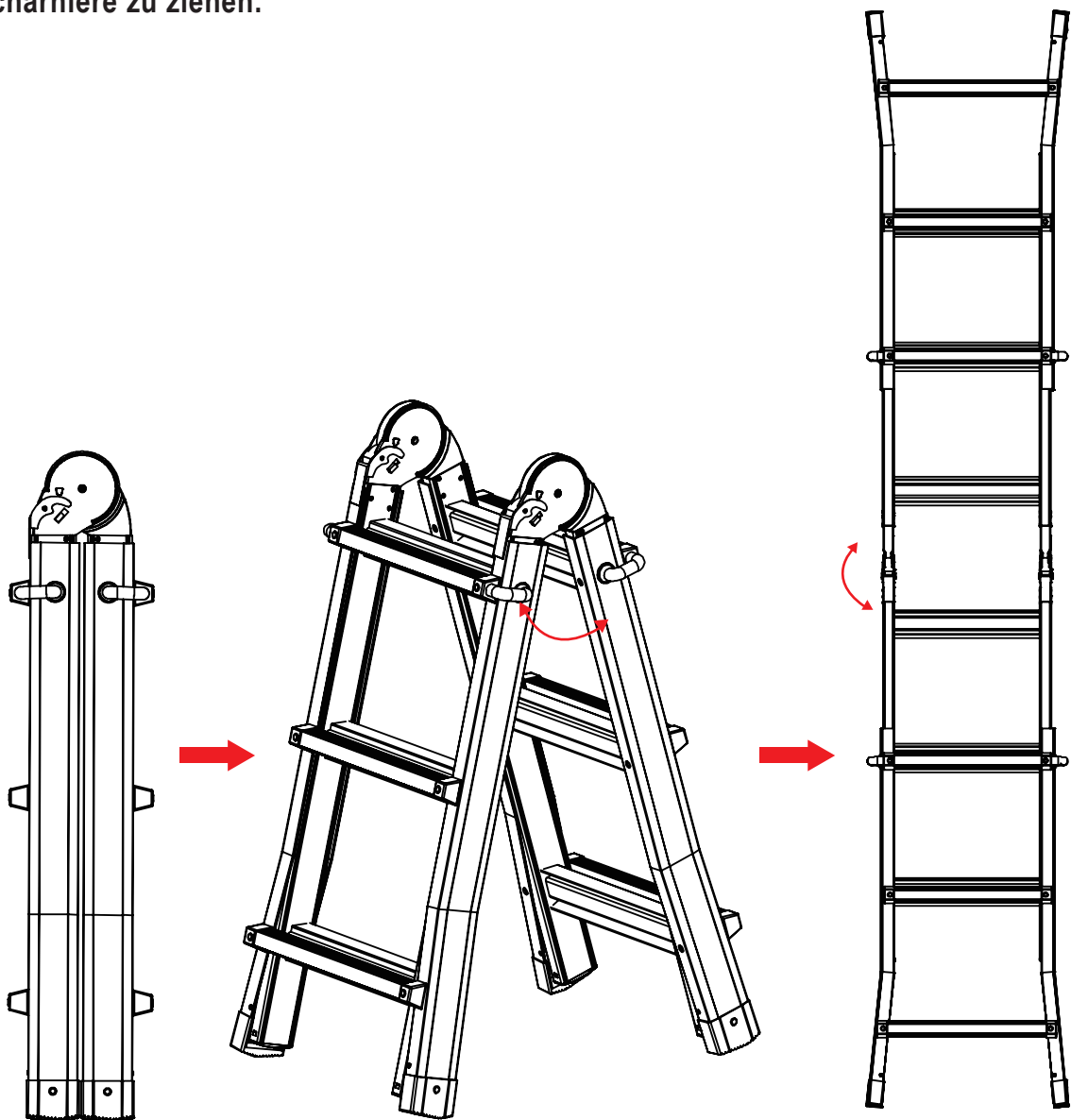

Die Scharniere ermöglichen der Leiter den Übergang zwischen Lagerung, A-Rahmen und Verlängerungskonfigurationen.

"J"-VERRIEGELUNG: Ändern Sie die Höhe Ihrer Leiter.

Gesperrt

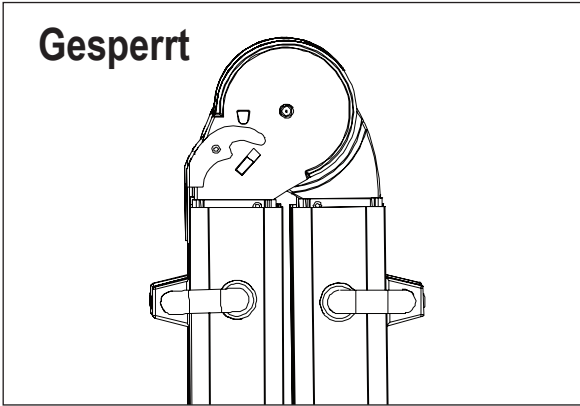

Entsperrt

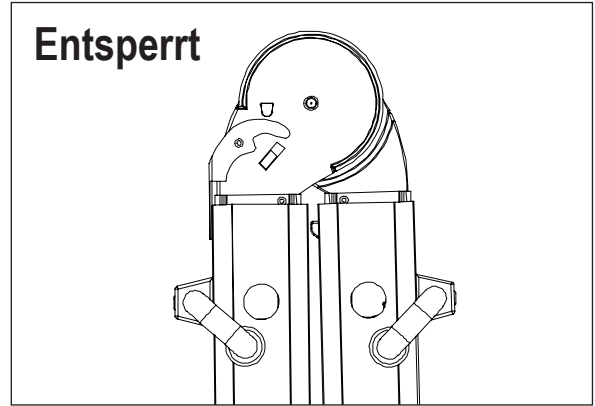

Um die Höhe anzupassen, befolgen Sie diese Schritte:

- Entriegeln Sie die Leiter, indem Sie die federbelastete 'J'-Verriegelung herausziehen.
- Verlängern Sie die Seitenschiene der Leiter auf die gewünschte Höhe.
- Drehen und richten Sie die 'J'-Verriegelung in das Sprossenloch, bis sie vollständig eingerastet ist.

Wichtig: Entriegeln Sie die 'J'-Verriegelung nicht, wenn sich jemand auf der Leiter befindet.

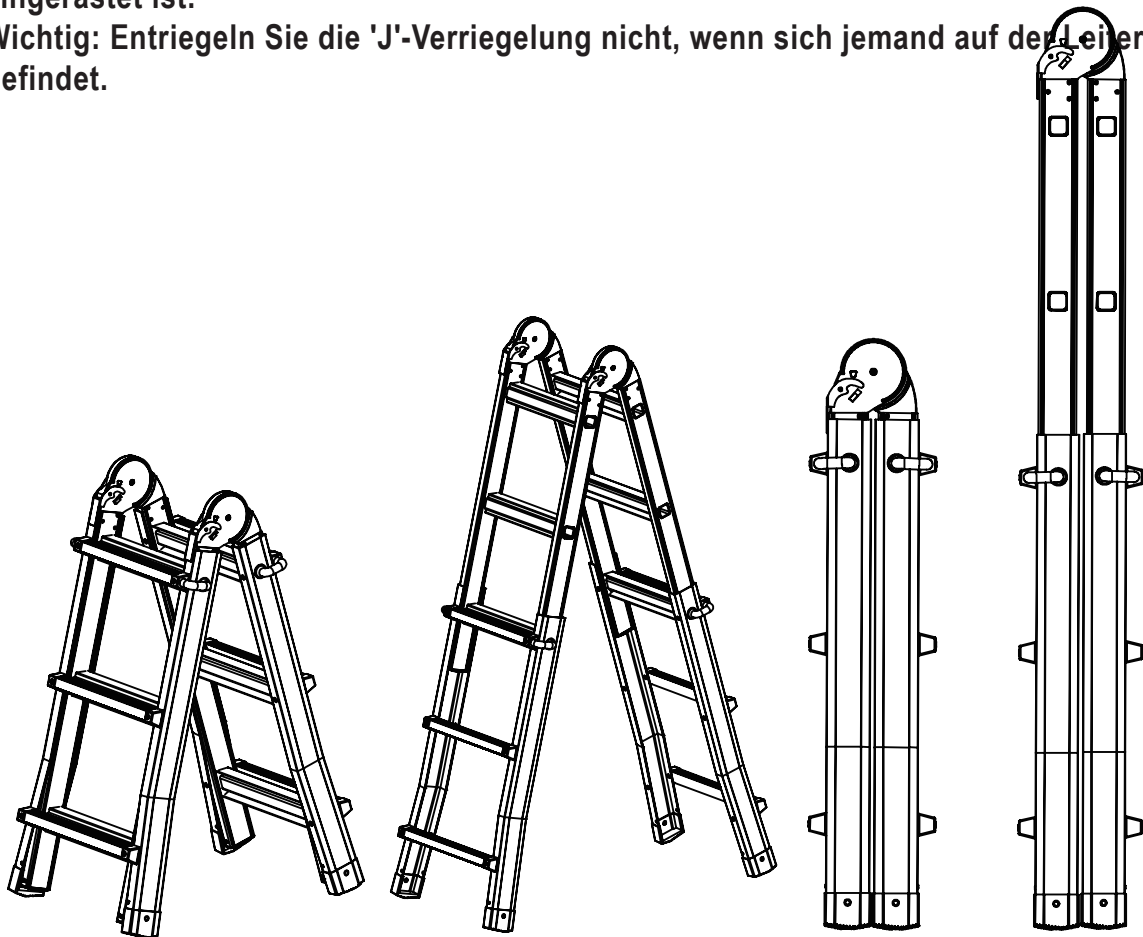

Stellen Sie die gewünschte Höhe ein.

PRODUKTÜBERSICHT

Eine vielseitige Leiter, die in verschiedene Positionen und Höhen eingestellt werden kann. Sie besteht aus drei Sektionen und verfügt über zwei verschiedene Verriegelungsmechanismen.

LEITERKONFIGURATIONEN

Die Leiter hat zwei Verriegelungsscharniere an jeder Seite und zwei federbelastete Verriegelungen an den äußeren Sektionen. Diese Scharniere ermöglichen die Verwendung der Leiter in vier verschiedenen Konfigurationen, einschließlich Verlängerungsleiter, Stehleiter, Treppenleiter und Gerüstmodus. In all diesen Konfigurationen, außer im Gerüstmodus, können Sie die Höhe nach Bedarf anpassen.

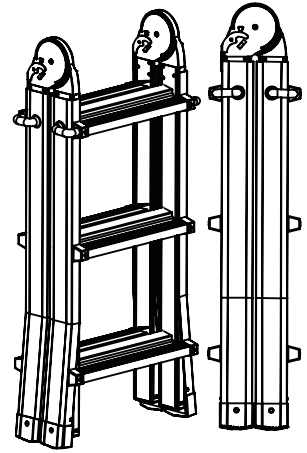

A-Rahmen Leiter

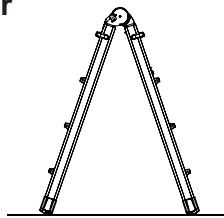

- NIEMALS zwischen den vorderen und hinteren Sektionen stehen (Grätschen).

- NIEMALS auf oder über der zweiten Sprosse von oben stehen.

Verlängerungsleiter



- NIEMALS auf den oberen drei Sprossen stehen.

- Stellen Sie sicher, dass der Winkel der Leiter ungefähr 75 Grad beträgt.



Verwenden Sie diese Leiter nur in den oben gezeigten Positionen. Jede andere Position, die nicht in diesem Handbuch gezeigt wird, kann zu schweren Verletzungen oder Tod führen.

Überschreiten Sie NICHT die maximale Belastung dieser Leiter. Siehe die Etiketten auf der Leiter.

CARDINE: Cambia la forma della tua scala.

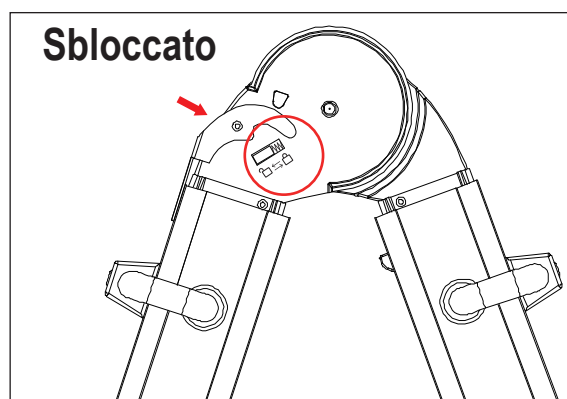
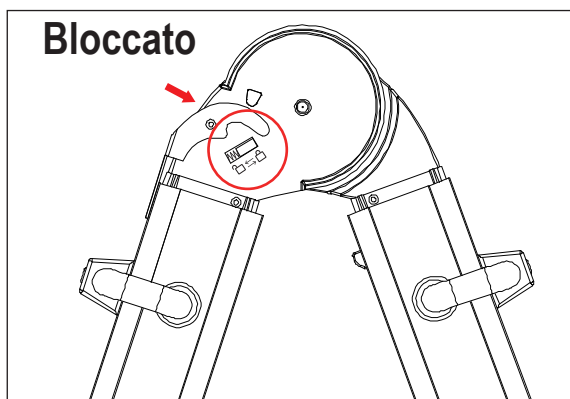

Usa le dita per tirare la fibbia di blocco su entrambi i lati dei cardini della scala.

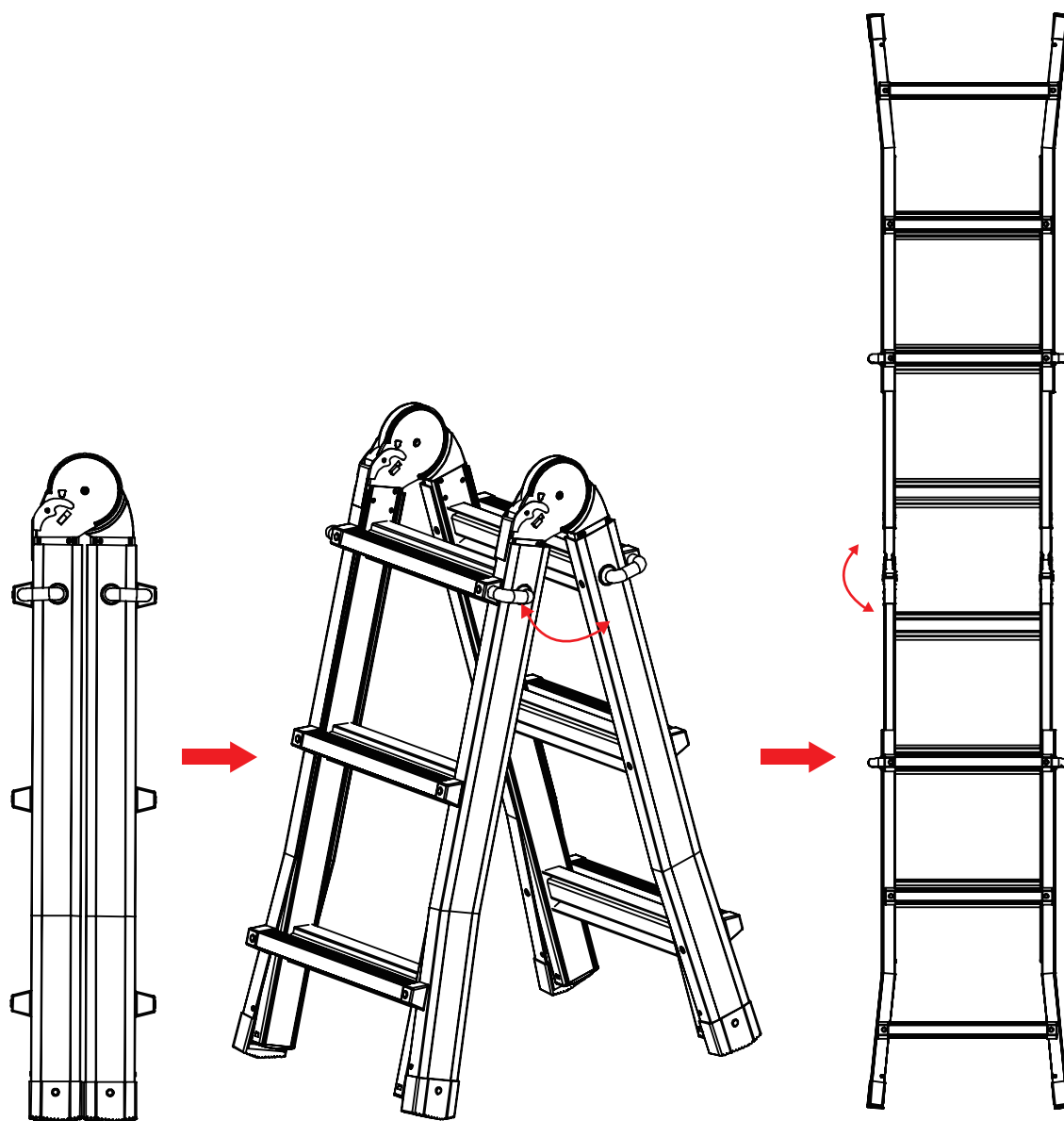

I cardini permettono alla scala di passare dalla posizione di stoccaggio, a telaio ad A, a configurazioni di estensione.

BLOCCO "J": Cambia l'altezza della tua scala.

Bloccato

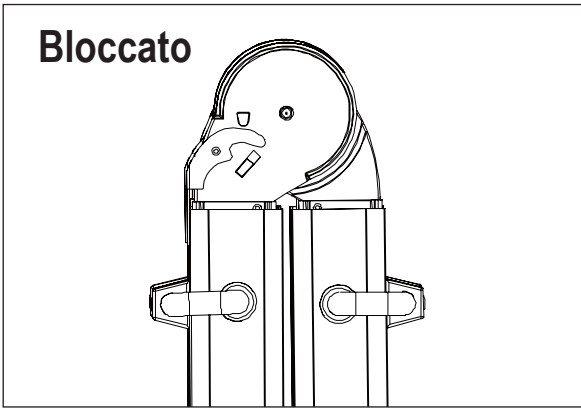

Sbloccato

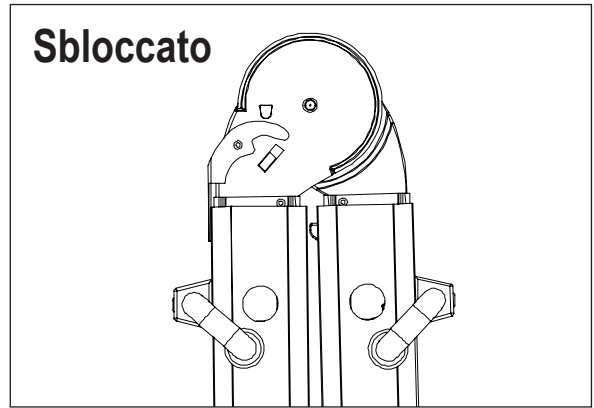

Per regolare l'altezza, segui questi passaggi:

- Sblocca la scala tirando il blocco a molla 'J'.
- Estendi il binario laterale della scala all'altezza desiderata.
- Ruota e allinea il blocco 'J' nel foro del piolo finché non è completamente inserito.

Importante: Non sbloccare il blocco 'J' se qualcuno è sulla scala.

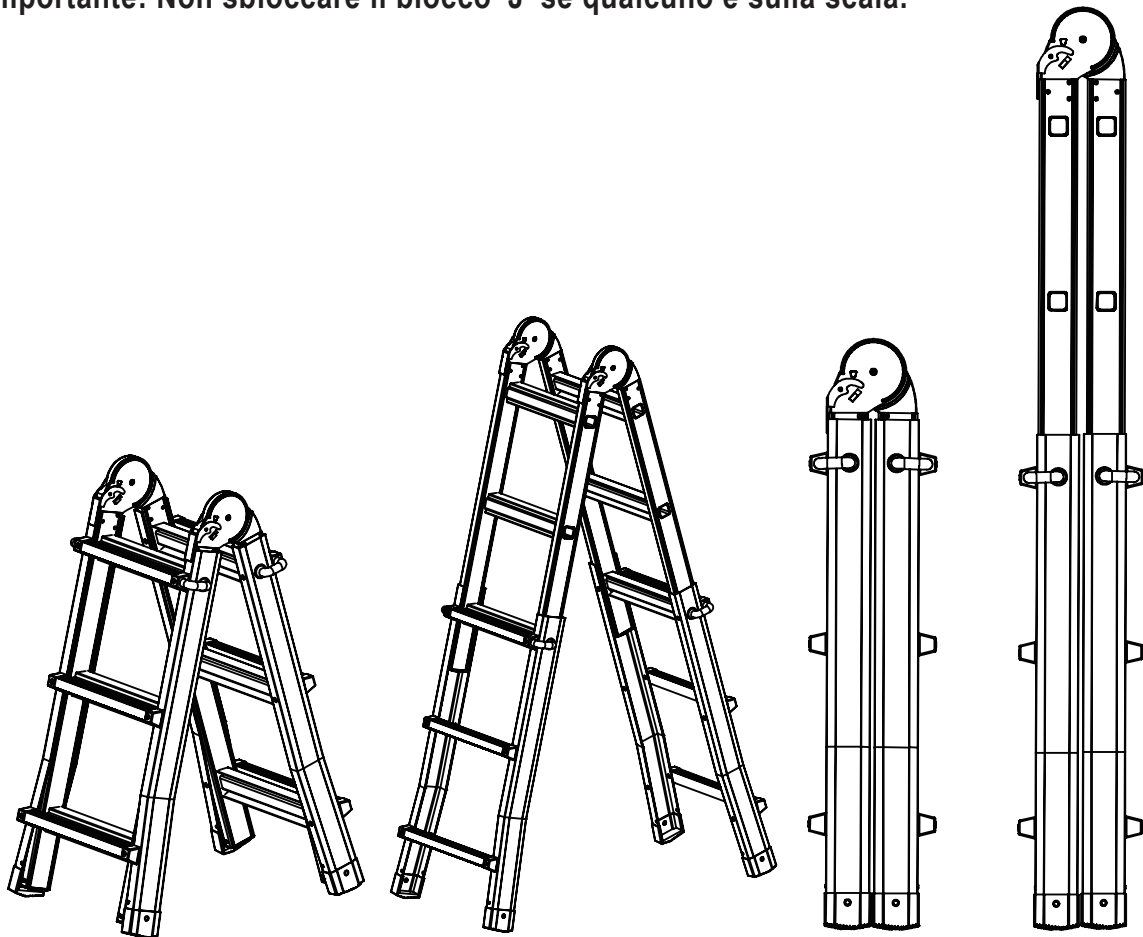

Regola l'altezza desiderata.

PANORAMICA DEL PRODOTTO

Una scala versatile che può essere regolata in varie posizioni e altezze. È composta da tre sezioni e ha due diversi meccanismi di bloccaggio.

CONFIGURAZIONI DELLA SCALA

La scala ha due cardini di bloccaggio su ciascun lato e due blocchi a molla sulle sezioni esterne. Questi cardini permettono alla scala di essere utilizzata in quattro diverse configurazioni, tra cui scala di estensione, scala a gradini, scala per scale e modalità impalcatura. In tutte queste configurazioni, tranne la modalità impalcatura, è possibile regolare l'altezza secondo le proprie esigenze.

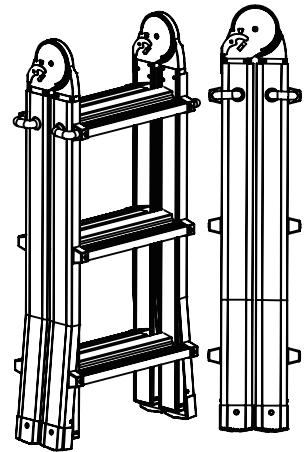

Scala a telaio ad A

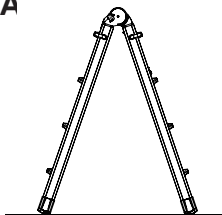

- NON stare mai tra le sezioni anteriori e posteriori (a cavallo).
- NON stare mai sulla seconda piolo dall'alto o sopra di essa.
- NON stare mai sui tre pioli superiori.
- Assicurarsi che l'angolo della scala sia di circa 75 gradi.

Scala di estensione



Utilizzare questa scala solo nelle posizioni sopra indicate. Qualsiasi altra posizione, non indicata in questo manuale, può comportare gravi infortuni o la morte.

NON superare il carico massimo di questa scala. Fare riferimento alle etichette sulla scala.

If you have any questions, please contact our customer care center, Our contact details are below:

US

 001-877-644-9366

 customerservice@aosom.com

Imported by Aosom LLC
27150 SW Kinsman Rd Wilsonville, OR 97070 USA
MADE IN CHINA

If you have any questions, please contact our customer care center, Our contact details are below:

UK

 0044-800-240-4004

 enquiries@mhstar.co.uk

IMPORTER ADDRESS:
MH STAR UK LTD
Unit 27, Perivale Park,
Horsenden lane South
Perivale, UB6 7RH
MADE IN CHINA

If you have any questions, please contact our customer care center, Our contact details are below:

CA

Si vous avez la moindre question, veuillez contacter notre centre d'assistance à la clientèle, Nos coordonnées sont les suivantes:

 416-792-6088

 customerservice@aosom.ca

Imported by Aosom Canada Inc.
7270 Woodbine Avenue, Unit 307, Markham,
Ontario Canada L3R 4B9
MADE IN CHINA

Importé par Aosom Canada Inc.
7270 Woodbine Avenue, unité 307, Markham,
Ontario Canada L3R 4B9
FABRIQUÉ EN CHINE

Wenn Sie Fragen haben, wenden Sie sich bitte an unser Kundendienstzentrum, Unsere Kontaktdaten stehen unten:

DE

 0049-0(40)-88307530

 service@aosom.de

ADRESSE DES IMPORTEUR/Hersteller/REP:
MH Handel GmbH Wendenstraße 309 D-20537
Hamburg
Germany
IN CHINA HERGESTELLT

In caso di dubbio, si prega di contattare il nostro centro assistenza clienti, I nostri dettagli di contatto sono di seguito:

IT

 0039-0249471447

 clienti@aosom.it

IMPORTATO DA/Produttore/REP: AOSOM Italy srl
Centro Direzionale Milanofiori Strada 1 Palazzo F1
20057 Assago (MI)
P.I.: 08567220960
FATTO IN CINA

Si tiene alguna pregunta, comuníquese con nuestro Centro de Atención al Cliente, Nuestros datos de contacto son los siguientes:

ES

 0034-931294512

 atencioncliente@aosom.es

IMPORTADOR/Fabricante/REP:
SPANISH AOSOM, S.L.
C/ROC GROS, Nº15.08550, ELS HOSTALET DE
BALENYÀ, SPAIN.
B66295775
HECHO EN CHINA

Se tiver alguma dúvida, por favor contacte o nosso Centro de Atendimento ao Cliente, Os nossos dados de contacto são os seguintes:

PT

 0034-931294512

 info@aosom.pt.

IMPORTADOR/Fabricante/REP: SPANISH
AOSOM, S.L C.ROC GROS N.15, 08550. ELS
HOSTALET DE BALENYÀ
FEITO NA CHINA

Si vous avez la moindre question, veuillez contacter notre centre d'assistance à la clientèle, Nos coordonnées sont les suivantes:

FR

 0033-1-84166106  aosom@mhfrance.fr

Importé par/Fabricant/REP: MH FRANCE 2 Rue Maurice Hartmann 92130 Issy Les Moulinaux
France
FABRIQUÉ EN CHINE



FR

**DONNEZ
OU
RECYCLEZ**



OU



OU



ASSOCIATION LIVRAISON DÉCHÈTERIE

Adresses sur quefairedemesdechets.fr