



***Suitable for children of 12-36 Months.**

***Max weight: 25 kg.**



New Holland Construction is a registered trademark owned by CNH Industrial N.V., in which CNH Industrial Italia S.p.A. has a proprietary interests, and it is used herein by Ningbo Prince Toys Co., Ltd. under a license agreement entered into with CNH Industrial Italia S.p.A.

IMPORTANT, RETAIN FOR FUTURE REFERENCE: READ CAREFULLY

ASSEMBLY INSTRUCTION

! WARNING:

1. This product is suitable for children for 12-36 months;
2. This product may have potential sharp edges, tips or small parts before assembly and must be assembled by adults;
3. Children should ride this on flat and smooth surface, and should keep away from traffic road; Strictly prohibited in nearby motor vehicles, streets, steps, slopes, hills, roads, alleys, swim-ming pools or other places with water;
4. This product shall be used under the custody of adults and shall wear shoes;
5. This product is only limited to one-person ride, with a maxi mum carrying capacity of 25 kg;
6. Adult assembly and installation of all parts are required.
7. Do not let Children playing alone with this product prevent from danger of Falling.
8. The toy should be used with caution since skill is required to avoid falls or collisions causing injury to the user or third parties.
9. Ensure this product is properly assembled before using.



















MAINTENANCE & CARE

- A. Keep all instructions and parts relating to this product for future reference.
- B. Regularly check for damage and that all screws are securely tightened.
- C. Check that the seat is securely fastened.
- D. Cleanness: Wipe clean with dry cloth on surface only.
- E. Storage: keep away from fire, damp and other high temperature area. Avoid direct Sun exposure.

Battery handling:

1. Battery must be handled by adults only.
2. Always remove exhausted batteries.
3. Do not mix old and new batteries.
4. Do not mix alkaline, standard (carbon-zinc) or rechargeable (nickel-cadmium) batteries.
5. Do not charge non-rechargeable batteries.
6. Before charging, remove chargeable batteries from the product.
7. Adult supervision is required when charging batteries.
8. Insert batteries with the correct polarity.
9. Ensure supply terminals are not short-circuited.
10. Rechargeable batteries are only to be charged under adult supervision.
11. Do not throw batteries into a fire – they could explode or leak.
12. Alkaline batteries are recommended.
13. When the product is not being used for a while, remove the batteries.
14. When changing batteries, ensure they are all changed with new ones.
15. Only use AA batteries.

COMPONENTS LIST

<p>1.Body 1pc</p> 	<p>2.Steering wheel 1pc</p> 	<p>3.Trailer 1pc</p> 
<p>4.Seat 1pc</p> 	<p>5.Exhaust-pipe 1pc</p> 	<p>6.Front wheel 2pcs</p> 
<p>7.Rear wheel cap 2pcs</p> 	<p>8.Rear wheel 2pcs</p> 	<p>9.Trailer wheel 2pcs</p> 
<p>10.Front wheel cap 4pcs</p> 	<p>11.Anti-tumble shelf 1pc</p> 	<p>12.Trailer connector 1pc</p> 
<p>13.J-sharped stick 1pc</p> 	<p>14.Wheel axle 2pcs</p> 	<p>15.Ring 6pcs</p> 
<p>16.Washer 7pcs (1replacement piece)</p> 	<p>17.Cotter pin 5pcs (1replacement piece)</p> 	<p>18.Black screw 2pcs (1replacement piece)</p> 
<p>19.Silver screw 4pcs (1replacement piece)</p> 	<p>20.Toy 2pcs</p> 	

Tractor assemble

Step 1

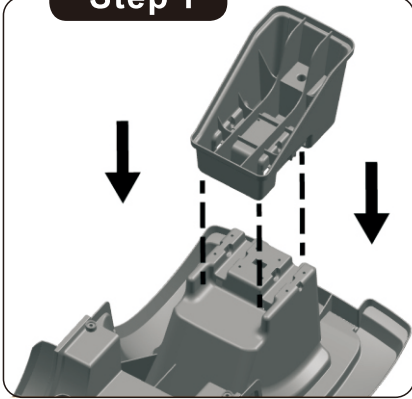

1. Place the anti-tumble shelf into the rear of the tractor body.

Step 2

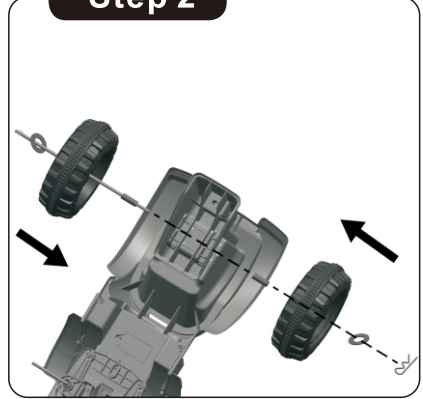

2. Insert the wheel axle through washer, rear wheel, plastic ring into the body, tighten using a cotter pin

Step 3

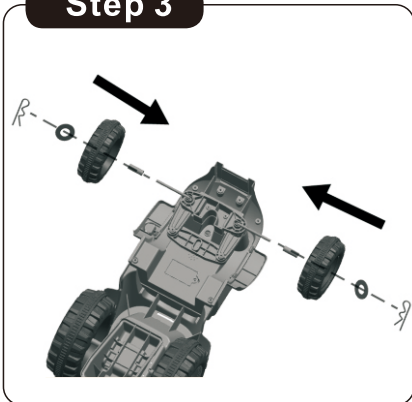

3. Assemble the two front wheels, insert the plastic ring, wheel and washer, tighten using a cotter pin.

Step 4

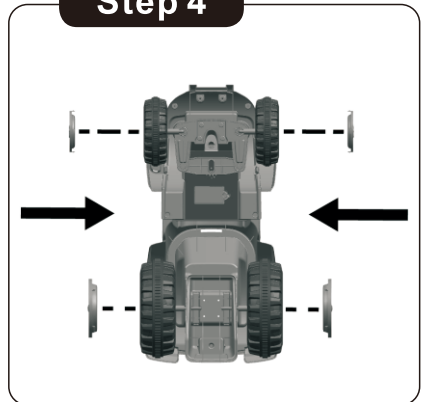

4. Place the two front wheel caps into the front wheels, and two rear wheel caps into the rear wheels.

Step 5

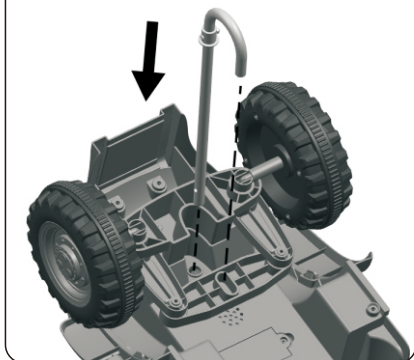

5. Install the J-shaped stick at the assigned location as picture.

Step 6

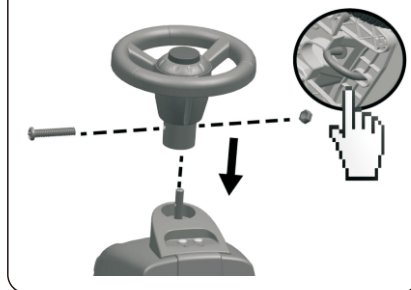

6. Loosen the bolt and nut in the steering wheel first, then place the steering wheel over the J-shaped stick, insert the bolt and tighten the nut with a screwdriver (not included)

Step 7



7. Assemble the seat, tighten with a black screw by a screwdriver (not included).

Step 8



8. Insert the exhaust pipe, be certain the exhaust pipe is completely seated.

Trailer assemble

Step 1

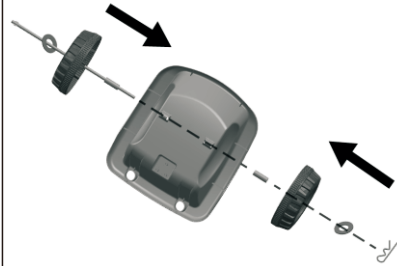

1. Insert the wheel axle through washer, trailer wheel, plastic ring into the trailer, tighten using a cotter pin.

Step 2

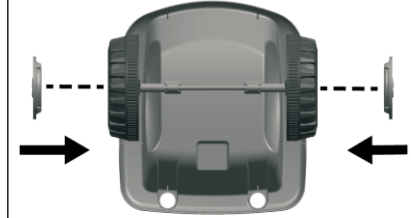

2. Place the two front wheel caps into the two trailer wheels.

Step 3

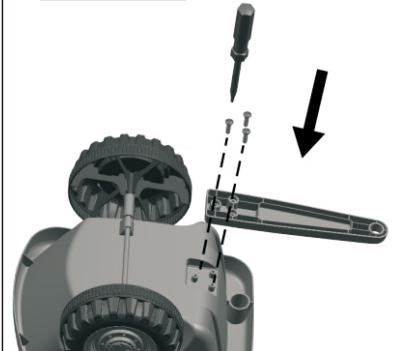

3. Assemble the trailer connector with three silver screws by a screwdriver (not included)

Step 4



4. Insert the two toys into the holes of the trailer.

Step 5

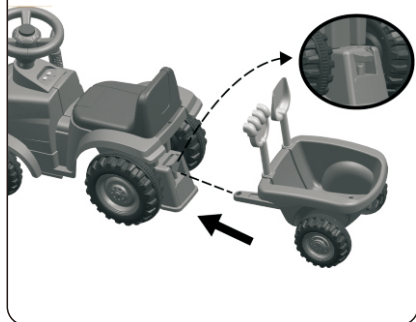

5. Open the lock and connect the trailer with tractor.

Battery change

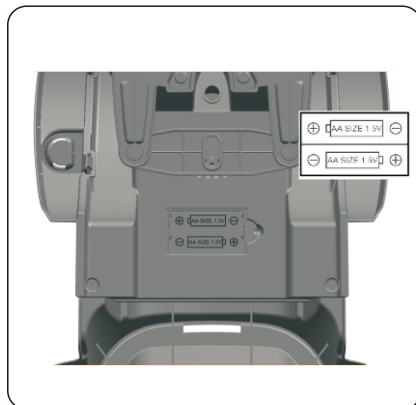
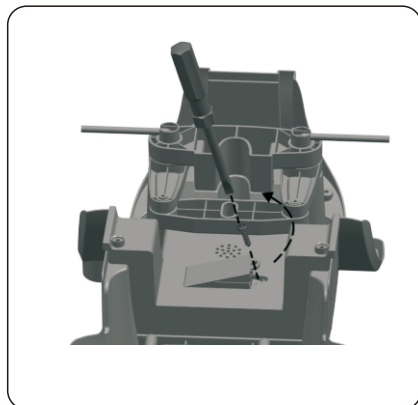

Turn over the tractor body, and find the battery house. Loosen the screw with a screwdriver (not included). Put 2 AA batteries in the battery house, then tight the screw with a screwdriver (not included).

Function

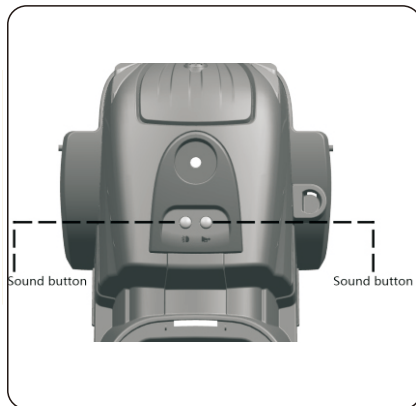
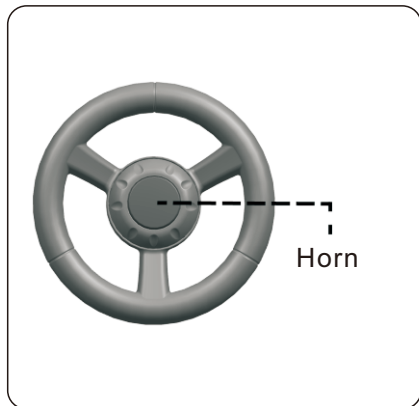

If you have any questions, please contact our customer care center.
Our contact details are below:

 0044-800-240-4004

 enquiries@mhstar.co.uk

IMPORTER ADDRESS:
MH STAR UK Ltd
1 Northampton Cross Logistics Park
Northampton Cross Road
Northampton
NN4 9FH
MADE IN CHINA



***Convient aux enfants de 12 à 36 Mois.**

***Poids maximum : 25 kg.**



New Holland Construction est une marque déposée appartenant à CNH Industrial N.V., dans laquelle CNH Industrial Italian S.p.A. a des intérêts de propriété, et elle est utilisée ici par Ningbo Prince Toys Co.,Ltd. en vertu d'un accord de licence conclu avec CNH Industrial Italian S.p.A.

IMPORTANT : LIRE ATTENTIVEMENT ET CONSERVEZ CE MANUEL POUR VOUS Y REFERER ULTERIEUREMENT.

ATTENTION:

1. Ce produit convient aux enfants de 12-36 mois ;
2. Ce produit peut comporter des arêtes vives, des pointes ou de petites pièces potentielles avant l'assemblage et doit être assemblé par des adultes ;
3. Les enfants doivent utiliser ce produit sur une surface plate et lisse, et doivent s'éloigner des routes de circulation ; Il est strictement interdit de l'utiliser à proximité de véhicules motorisés, de rues, d'escaliers, de pentes, de collines, de routes, d'allées, de piscines ou d'autres endroits avec de l'eau ;
4. Ce produit doit être utilisé sous la surveillance d'adultes et doit être porté avec des chaussures ;
5. Ce produit est limité à une seule personne, avec une capacité de charge maximale de 25 kg ;
6. L'assemblage et l'installation de toutes les pièces doivent être effectués par un adulte.
7. Ne laissez pas les enfants jouer seuls avec ce produit pour éviter les chutes.
8. Le jouet doit être utilisé avec prudence car des compétences sont nécessaires pour éviter les chutes ou les collisions pouvant causer des blessures à l'utilisateur ou à des tiers.
9. Assurez-vous que ce produit est correctement assemblé avant de l'utiliser.



ENTRETIEN ET MAINTENANCE

- A. Conservez toutes les instructions et les pièces relatives à ce produit pour pouvoir vous y référer ultérieurement.
- B. Vérifiez régulièrement que le produit n'est pas endommagé et que toutes les vis sont bien serrées.
- C. Vérifier que le siège est bien fixé.
- D. Propreté: Essuyer uniquement la surface avec un chiffon sec.
- E. Stockage: Tenez à l'écart du feu, de l'humidité et d'autres zones à haute température. Éviter une exposition directe au soleil.

Manipulation de la pile:

1. La pile doit être manipulée par des adultes uniquement.
2. Retirez toujours les piles mortes.
3. Ne mélangez pas les anciennes et les nouvelles piles.
4. Ne mélangez pas des piles alcalines, standard (carbone-zinc) ou rechargeables (nickel-cadmium).
5. Ne chargez pas les piles non rechargeables.
6. Avant de charger les piles, retirez-les du produit.
7. La surveillance d'un adulte est requise lors du chargement des piles.
8. Insérez les piles en respectant la polarité.
9. Veillez à ce que les bornes d'alimentation ne soient pas court-circuitées.
10. Pour les jouets électriques utilisant des accumulateurs rechargeables, il convient que les accumulateurs soient chargés sous le contrôle d'un adulte.
11. Ne jetez pas de piles dans un feu - elles pourraient provoquer une explosion ou suinter dans le sol.
12. Il est recommandé d'utiliser des piles alcalines.
13. Retirez les piles lorsque le produit n'est pas utilisé pendant un certain temps.
14. Lorsque vous changez les piles, assurez-vous qu'elles sont toutes remplacées par des piles neuves.
15. N'utilisez que des piles AA.

LISTE DES COMPOSANTS

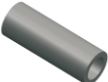
<p>1.Carrosserie 1pc</p> 	<p>2.Volant de direction 1pc</p> 	<p>3.Remorque 1pc</p> 
<p>4.Siège 1pc</p> 	<p>5.Tuyau d'échappement 1pc</p> 	<p>6.Roue avant 2pcs</p> 
<p>7.Enjoliveur de roue arrière 2pcs</p> 	<p>8.Roue arrière 2pcs</p> 	<p>9.Roue de remorque 2pcs</p> 
<p>10.Enjoliveur de roue avant 4pcs</p> 	<p>11.Support anti- basculement 1pc</p> 	<p>12.Connecteur de remorque 1pc</p> 
<p>13.Tige en J 1pc</p> 	<p>14.Axe de roue 2pcs</p> 	<p>15.Anneau 6pcs</p> 
<p>16.Rondelle 7pcs (1 pièce de rechange)</p> 	<p>17.Goupille fendue 5pcs (1 pièce de remplacement)</p> 	<p>18.Vis noire 2pcs (1 pièce de remplacement)</p> 
<p>19.Vis argentée 4pcs (1 pièce de rechange)</p> 	<p>20.Jouet 2pcs</p> 	

Assemblage du tracteur

Étape 1

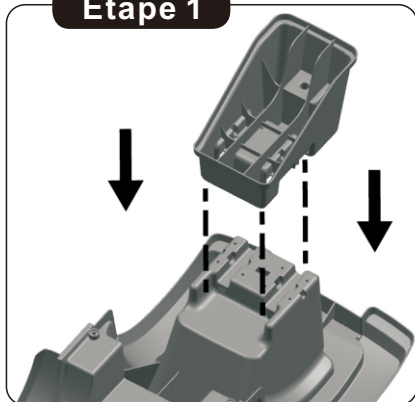

1. Placer le support anti-basculement à l'arrière de la carrosserie du tracteur.

Étape 2

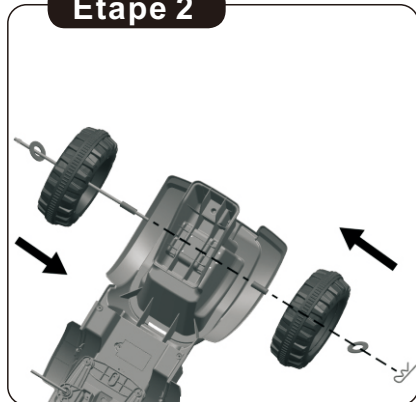

2. Insérez l'axe de la roue à travers la rondelle, la roue arrière et la bague en plastique dans la carrosserie, serrez à l'aide d'une gouille fendue.

Étape 3

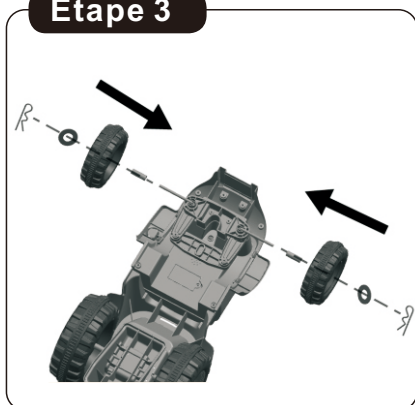

3. Assembler les deux roues avant, insérer l'anneau en plastique, la roue et la rondelle, serrer à l'aide d'une gouille fendue.

Étape 4

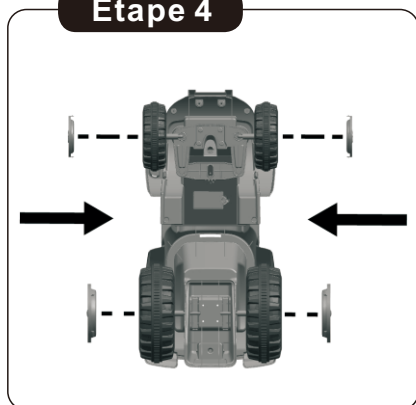

4. Placez les deux enjoliveurs de roues avant dans les roues avant et les deux enjoliveurs de roues arrière dans les roues arrière.

Étape 5

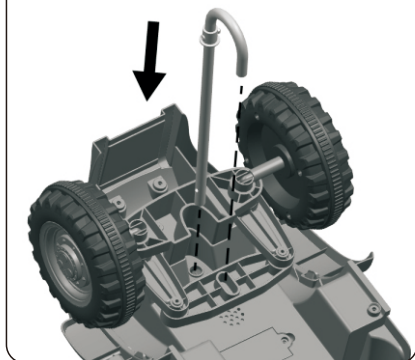

5. Installez la tige en J à l'endroit indiqué sur la photo.

Étape 6

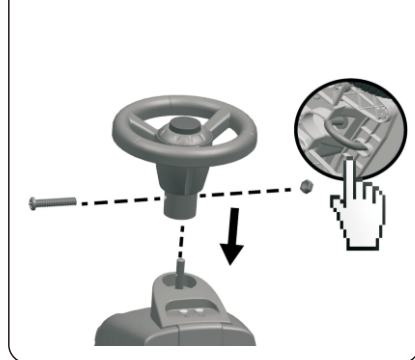

6. Desserrez d'abord le boulon et l'écrou du volant, puis placez le volant sur la tige en J, insérez le boulon et serrez l'écrou avec un tournevis (non inclus)

Étape 7



7. Assembler le siège, serrer avec une vis noire à l'aide d'un tournevis (non inclus).

Étape 8



8. Insérez le tuyau d'échappement, assurez-vous que le tuyau d'échappement est complètement positionné.

Assemblage du tracteur

Étape 1

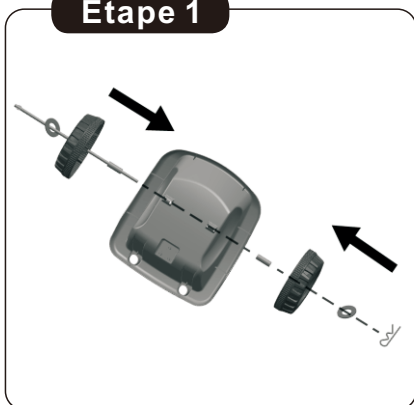

1. Insérez l'axe de la roue à travers la rondelle, la roue de la remorque et l'anneau en plastique dans la remorque, serrez à l'aide d'une goupille fendue.

Étape 2

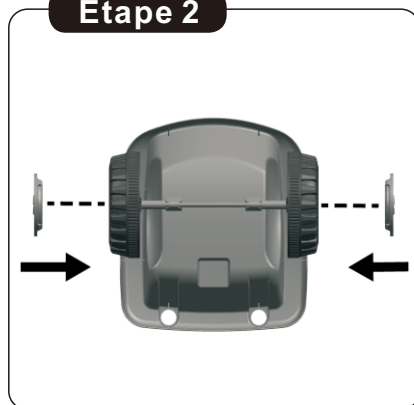

2. Placez les deux enjoliveurs de roue avant dans les deux roues de la remorque.

Étape 3

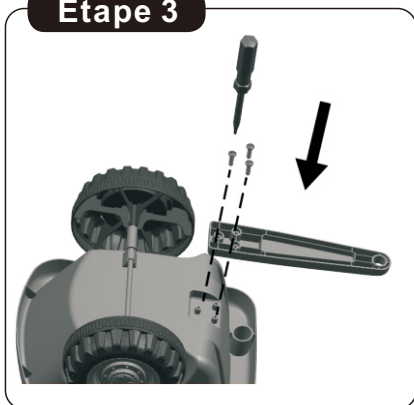

3. Assembler le connecteur de la remorque à l'aide d'un tournevis et de trois vis à tête plate (non fournies)

Étape 4

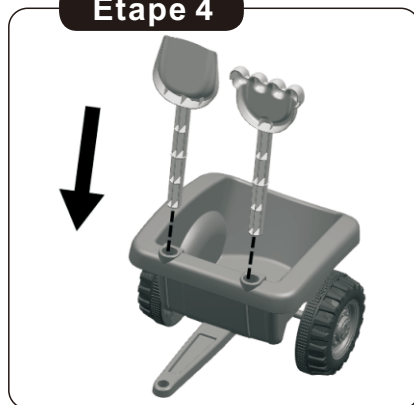

4. Insérez les deux jouets dans les trous prévus à cet effet dans la remorque.

Étape 5

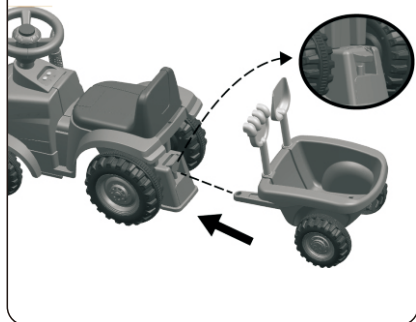

5. Ouvrir le verrou et connecter la remorque au tracteur.

Changement des piles

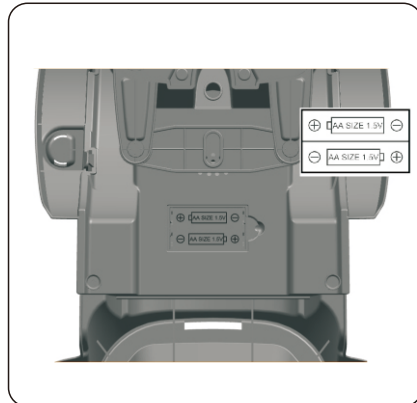
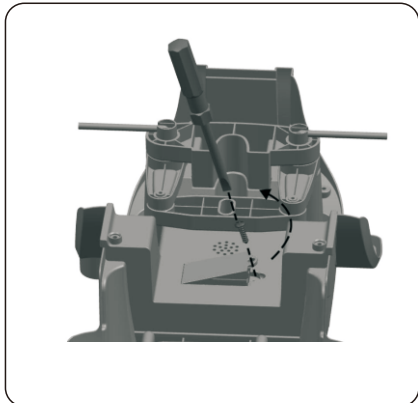

Retournez la carrosserie du tracteur et repérez le logement des piles. Dévissez la vis à l'aide d'un tournevis (non inclus). Placez 2 piles AA dans le logement des piles, puis serrez la vis à l'aide d'un tournevis (non inclus).

Fonction

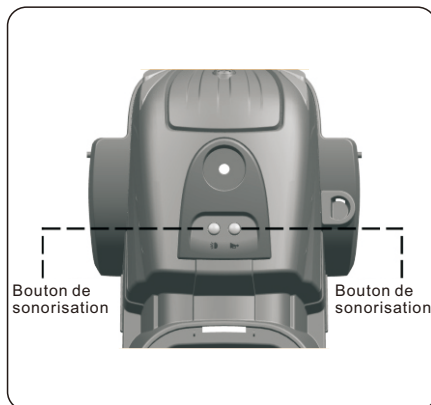
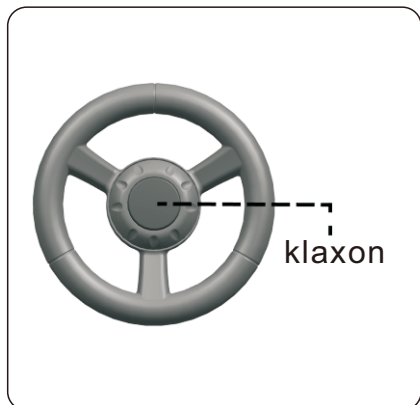

FR
Cet appareil,
ses accessoires,
cordons et batteries
se recyclent

REPRISE
À LA LIVRAISON



OU

À DÉPOSER
EN MAGASIN



OU

À DÉPOSER
EN DÉCHÈTERIE



Points de collecte sur www.quefairedemesdechets.fr
Privilégiez la réparation ou le don de votre appareil !

Si vous avez la moindre question, veuillez contacter notre centre d'assistance à la clientèle.

Nos coordonnées sont les suivantes:

 0033-1-84166106

 aosom@mhfrance.fr

Importé par/Fabricant/REP:
MH France
2, rue Maurice Hartmann
92130 Issy-les-Moulineaux
France
FABRIQUÉ EN CHINE



***Geeignet für Kinder im Alter von 12-36 Monate .**

***Max. Gewicht: 25 kg.**



New Holland Construction ist eine eingetragene Marke von CNH Industrial N.V., an der CNH Industrial Italian S.p.A. ein Eigentumsrecht hat, und wird hier von Ningbo Prince Toys Co., Ltd. im Rahmen einer Lizenzvereinbarung mit CNH Industrial Italian S.p.A. verwendet.

WICHTIG! SORGFÄLTIG LESEN UND FÜR SPÄTER NACHSCHLAGEN AUFBEWAHREN.



ACHTUNG:

1. Dieses Produkt ist für Kinder ab 12-36 Monaten geeignet;
2. Dieses Produkt kann vor dem Zusammenbau potenziell scharfe Kanten, Spitzen oder kleine Teile aufweisen und muss von Erwachsenen zusammengebaut werden;
3. Kinder sollten damit auf einer flachen und glatten Oberfläche fahren und sich von Verkehrsstraßen fernhalten; In der Nähe von Kraftfahrzeugen, Straßen, Treppen, Hügeln, Straßen, Gassen, Schwimmbädern oder anderen Orten mit Wasser ist es strengstens verboten.
4. Dieses Produkt sollte unter Aufsicht von Erwachsenen verwendet werden und Schuhe getragen werden;
5. Dieses Produkt ist nur für eine Person mit einem maximalen Tragegewicht von 25 kg geeignet;
6. Der Zusammenbau und die Installation aller Teile erfordern die Aufsicht eines Erwachsenen.
7. Lassen Sie Kinder nicht alleine mit diesem Produkt spielen, um Stürze zu verhindern.
8. Das Spielzeug sollte vorsichtig verwendet werden, da Geschicklichkeit erforderlich ist, um Stürze oder Kollisionen zu vermeiden, die dem Benutzer oder Dritten Verletzungen zufügen könnten.
9. Stellen Sie vor der Verwendung sicher, dass das Produkt richtig zusammengebaut ist.



WARTUNG & PFLEGE

- A. Bewahren Sie alle Anweisungen und Teile, die sich auf dieses Produkt beziehen, zur späteren Verwendung auf.
- B. Prüfen Sie es regelmäßig auf Beschädigungen und ob alle Schrauben fest angezogen sind.
- C. Prüfen Sie, ob der Sitz sicher befestigt ist.
- D. Sauberkeit: Nur die Oberfläche mit einem trockenen Tuch abwischen.
- E. Lagerung: Halten Sie es von Feuer, Feuchtigkeit und anderen Bereichen mit hohen Temperaturen fern. Direkte Sonneneinstrahlung vermeiden.

Handhabung der Batterie:

1. Die Batterie darf nur von Erwachsenen gehandhabt werden.
2. Entfernen Sie immer leere Batterien.
3. Vermischen Sie alte und neue Batterien nicht.
4. Mischen Sie keine Alkali-, Standard- (Kohle-Zink) oder wiederaufladbare (Nickel-Cadmium) Batterien.
5. Laden Sie keine nicht wiederaufladbaren Batterien auf.
6. Nehmen Sie aufladbare Batterien vor dem Aufladen aus dem Produkt.
7. Das Laden von Batterien muss unter Aufsicht von Erwachsenen erfolgen.
8. Setzen Sie die Batterien mit der richtigen Polarität ein.
9. Stellen Sie sicher, dass die Versorgungsklemmen nicht kurzgeschlossen sind.
10. Bei elektrischen Spielzeugen, die aufladbare Batterien benutzen, sollen die Batterien unter Aufsicht von Erwachsenen geladen werden.
11. Werfen Sie Batterien nicht ins Feuer – sie könnten explodieren oder auslaufen.
12. Es werden Alkalibatterien empfohlen.
13. Entfernen Sie die Batterien, wenn das Produkt eine Zeit lang nicht benutzt wird.
14. Achten Sie beim Auswechseln der Batterien darauf, dass alle durch neue ersetzt werden.
15. Verwenden Sie nur AA-Batterien.

KOMPONENTENLISTE

<p>1. Karosserie 1 Stück</p> 	<p>2. Lenkrad 1 Stück</p> 	<p>3. Anhänger 1 Stück</p> 
<p>4. Sitz 1 Stück</p> 	<p>5. Auspuffrohr 1 STÜCK</p> 	<p>6. Vorderrad 2 Stück avant 2pcs</p> 
<p>7. Radkappe hinten 2 Stück</p> 	<p>8. Hinterrad 2 Stück</p> 	<p>9. Anhängerrad 2 Stück</p> 
<p>10. Vorderradkappe 4 Stück</p> 	<p>11. Kippschutz Ablage 1 Stück</p> 	<p>12. Anhängerstecker 1 Stück</p> 
<p>13. J-Stock 1 Stück</p> 	<p>14. Radachse 2 Stück</p> 	<p>15. Ring 6 Stück</p> 
<p>16. Unterlegscheibe 7 Stück (1 Ersatzteil)</p> 	<p>17. Splint 5 Stück (1 Ersatzteil)</p> 	<p>18. Schraube schwarz 2 Stück (1 Ersatzteil)</p> 
<p>19. Schraube silber 4 Stück (1 Ersatzteil)</p> 	<p>20. Spielzeug 2 Stück</p> 	

Montage des Traktors

Schritt 1

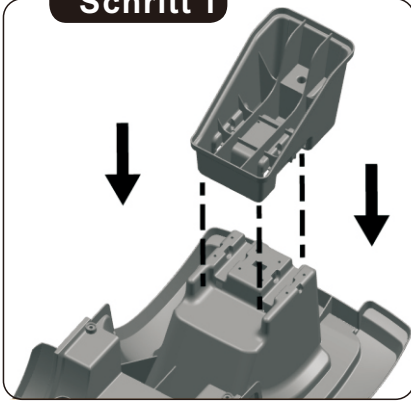

1. Setzen Sie den Kippschutz in das Heck der Traktorkarosserie.

Schritt 2

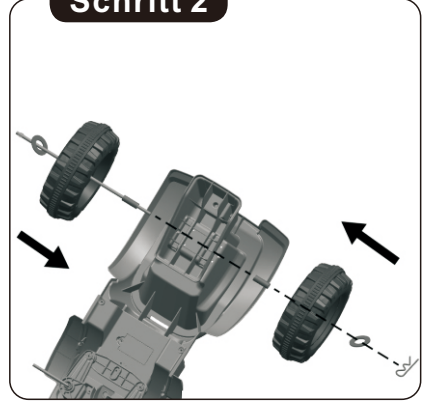

2. Setzen Sie die Radachse durch die Unterlegscheibe, das Hinterrad und den Kunststoffring in die Karosserie ein und ziehen Sie sie mit einem Splint fest.

Schritt 3

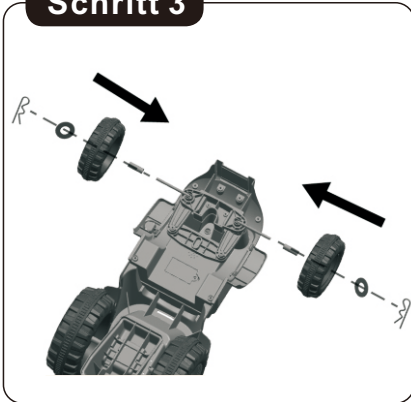

3. Montieren Sie die beiden Vorderräder, setzen Sie den Kunststoffring, das Rad und die Unterlegscheibe ein und ziehen Sie sie mit einem Splint fest.

Schritt 4

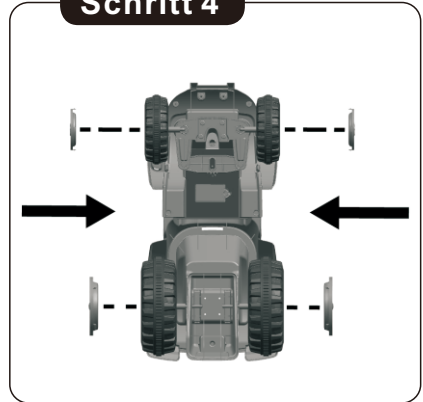

4. Setzen Sie die beiden vorderen Radkappen auf die Vorderräder, die beiden hinteren Radkappen auf die Hinterräder.

Schritt 5

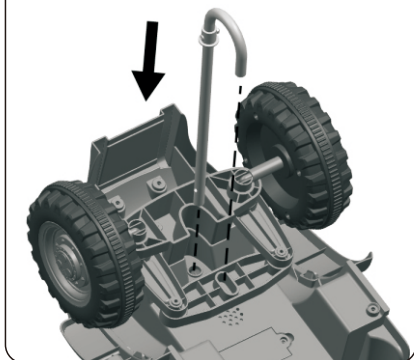

5. Montieren Sie den J-Stock an der zugewiesenen Stelle wie abgebildet.

Schritt 6

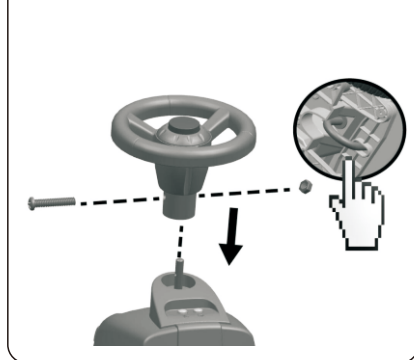

6. Lösen Sie zuerst die Schraube und die Mutter im Lenkrad, setzen Sie dann das Lenkrad über den J-förmigen Stock, setzen Sie die Schraube und ziehen Sie die Mutter mit einem Schraubendreher (nicht im Lieferumfang enthalten) fest.

Schritt 7

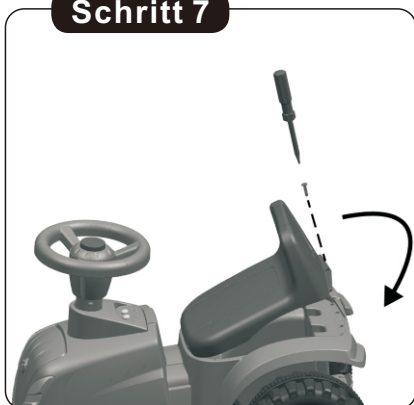

7. Montieren Sie den Sitz, ziehen Sie die schwarze Schraube mit einem Schraubendreher fest (nicht im Lieferumfang enthalten).

Schritt 8



8. Setzen Sie das Auspuffrohr ein, stellen Sie sicher, dass das Auspuffrohr vollständig sitzt.

Montage des Traktors

Schritt 1

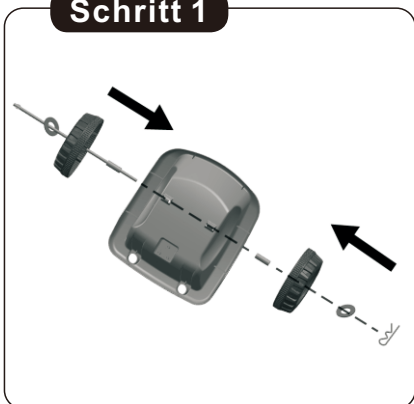

1. Stecken Sie die Radachse durch die Unterlegscheibe, das Anhängerrad und den Kunststoffring in den Anhänger, ziehen Sie sie mit einem Splint fest.

Schritt 2

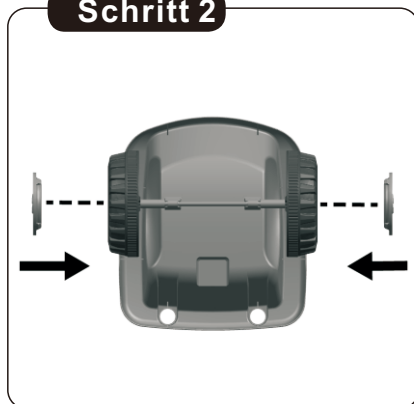

2. Setzen Sie die beiden vorderen Radkappen auf beide Anhängerräder.

Schritt 3

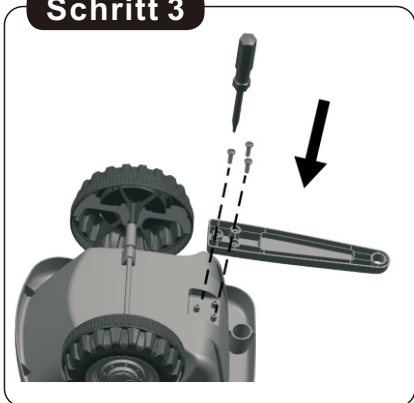

3. Montieren Sie den Anhängeranschluss mit drei Splitterschrauben mit einem Schraubendreher (nicht im Lieferumfang enthalten)

Schritt 4

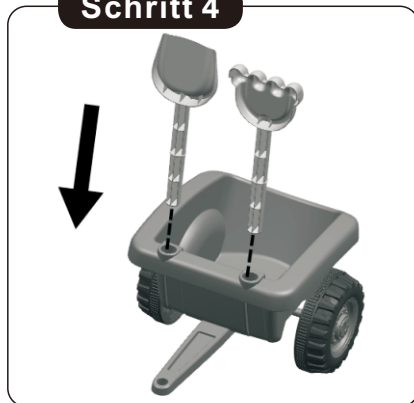

4. Stecken Sie die beiden Spielzeuge in die Löcher des Anhängers.

Schritt 5

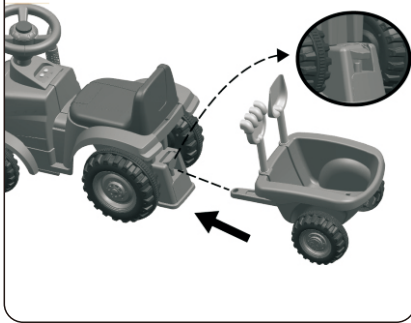

5. Öffnen Sie das Schloss und verbinden Sie den Anhänger mit dem Traktor.

Batteriewechsel

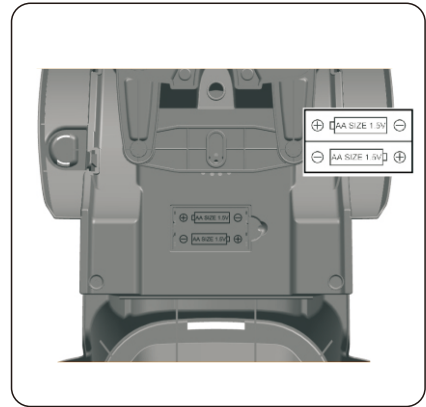
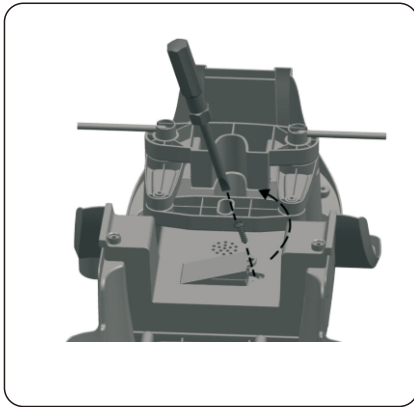

Drehen Sie die Traktorkarosserie um, und suchen Sie das Batteriefach. Lösen Sie die Schraube mit einem Schraubendreher (nicht im Lieferumfang enthalten), legen Sie 2 AA-Batterien in das Batteriefach und ziehen Sie die Schraube mit einem Schraubendreher fest (nicht im Lieferumfang enthalten).

Funktion

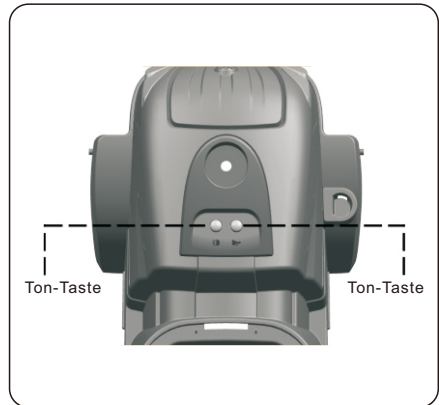
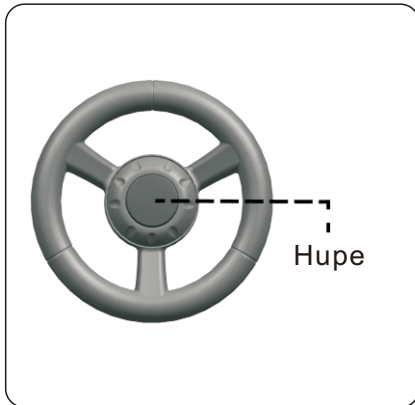

Wenn Sie Fragen haben, wenden Sie sich bitte an unser Kundendienstzentrum.

Unsere Kontaktdaten stehen unten:

 0049-0(40)-87408465

 service@aosom.de

Importeur/Hersteller/REP:
MH Handel GmbH
Wendenstraße 309
D-20537 Hamburg
Germany
IN CHINA HERGESTELLT

12-36
 mesi

* Adatto a bambini di 12-36 mesi.

* Peso massimo: 25 kg.



New Holland Construction è un marchio registrato di proprietà di CNH Industrial N.V., in cui CNH Industrial Italian S.p.A. ha interessi proprietari, ed è utilizzato nel presente manuale da Ningbo Prince Toys Co., Ltd. a secondo di un accordo di licenza stipulato con CNH Industrial Italian S.p.A.

IMPORTANTE! CONSERVARE IL PRESENTE MANUALE PER FUTURO RIFERIMENTO E LEGGERLO ATTENTAMENTE.



AVVERTENZA:

1. Questo prodotto è adatto a bambini di età compresa tra 12 e 36 mesi.
2. Prima dell'assemblaggio, il prodotto potrebbe presentare bordi taglienti, punte o piccole parti; l'assemblaggio deve essere effettuato esclusivamente da un adulto.
3. I bambini devono utilizzare questo prodotto su superfici piatte e lisce e tenersi alla larga dalle strade trafficate. È severamente vietato l'uso in prossimità di veicoli a motore, strade, gradini, pendii, colline, vicoli, piscine o altri luoghi con acqua.
4. Questo prodotto deve essere utilizzato sotto la supervisione di un adulto e il bambino deve indossare le scarpe.
5. Questo prodotto è destinato all'uso individuale, con un carico massimo consentito di 25 kg.
6. È richiesto che un adulto assembli e installi tutti i componenti.
7. Non lasciare che i bambini giochino con questo prodotto da soli, per evitare il rischio di caduta.
8. Il giocattolo deve essere utilizzato con cautela, poiché è richiesta una certa destrezza per evitare cadute o collisioni che potrebbero causare lesioni all'utente o a terzi.
9. Assicurarsi che questo prodotto sia assemblato correttamente prima dell'uso.

MANUTENZIONE & CURA

- A. Conservare tutte le istruzioni e le parti relative a questo prodotto per riferimenti futuri.
- B. Verificare regolarmente la presenza di danni e che tutte le viti siano strette saldamente.
- C. Verificare che il sedile sia fissato in sicurezza.
- D. Pulizia: Pulire solo la superficie con un panno asciutto.
- E. Conservazione: tenere lontano da fuoco, umidità e aree ad alta temperatura. Evitare l'esposizione diretta al sole.

Gestione delle batterie:

1. Le batterie devono essere maneggiate solo da adulti.
2. Rimuovere sempre le batterie scariche.
3. Non mischiare batterie vecchie e nuove.
4. Non mischiare batterie alcaline, standard (carbone-zinco) o ricaricabili (nichel-cadmio).
5. Non tentare di ricaricare batterie non ricaricabili.
6. Prima della ricarica, rimuovere le batterie ricaricabili dal prodotto.
7. È necessaria la supervisione di un adulto durante la ricarica delle batterie.
8. Inserire le batterie secondo la polarità corretta.
9. Assicurarsi che i terminali di alimentazione non siano in stato di cortocircuito.
10. Le batterie ricaricabili devono essere caricate solo sotto supervisione di un adulto.
11. Non smaltire le batterie nel fuoco: potrebbero esplodere o potrebbero esserci perdite.
12. Si consiglia l'uso di batterie alcaline.
13. Quando il prodotto non viene utilizzato a lungo, rimuovere le batterie.
14. Quando si sostituiscono le batterie, assicurarsi che siano tutte sostituite con batterie nuove.
15. Utilizzare solo batterie AA.

EIENCO DEI COMPONENTI

<p>1. Corpo 1 pz</p> 	<p>2. Volante 1 pz</p> 	<p>3. Rimorchio 1 pz</p> 
<p>4. Sedile 1 pz</p> 	<p>5. Tubo di scarico 1 pz</p> 	<p>6. Ruota anteriore 2 pz</p> 
<p>7. Coperchio della Ruota posteriore 2 pz</p> 	<p>8. Ruota posteriore 2 pz</p> 	<p>9. Ruota Rimorchio 2 pz</p> 
<p>10. Coperchio della Ruota anteriore 4 pz</p> 	<p>11. Supporto anti caduta 1 pz</p> 	<p>12. Connettore rimorchio 1 pz</p> 
<p>13. Bastoncino a forma J 1 pz</p> 	<p>14. Asse ruota 2 pz</p> 	<p>15. Anello 6 pz</p> 
<p>16. Rondella 7 pz (1 replacement piece)</p> 	<p>17. Coppiglia 5 pz (1 pezzo di sostituzione)</p> 	<p>18. vite nera 2 pz (1 pezzo di sostituzione)</p> 
<p>19. Vite d'argento 4 pz (1 pezzo di sostituzione)</p> 	<p>20. Giocattolo 2 pz</p> 	

Assemblaggio Trattore

Passaggio 1

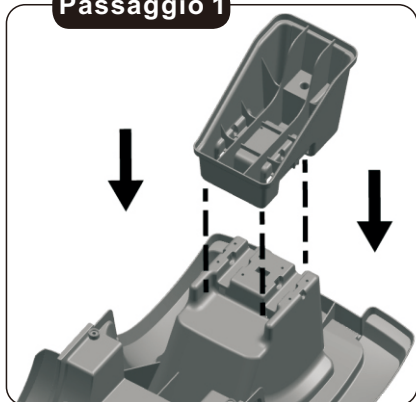

1. Posizionare il supporto anti-caduta nella parte posteriore del corpo del trattore.

Passaggio 2

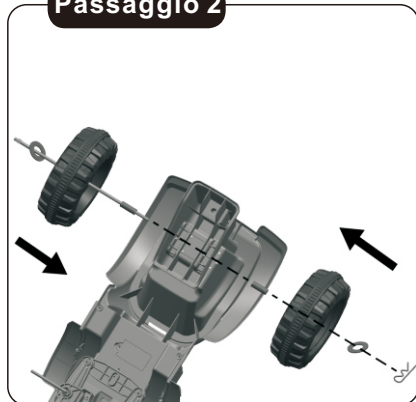

2. Inserire l'asse della ruota attraverso la rondella, montare la ruota posteriore, l'anello di plastica nel corpo, fissare con una coppiglia.

Passaggio 3

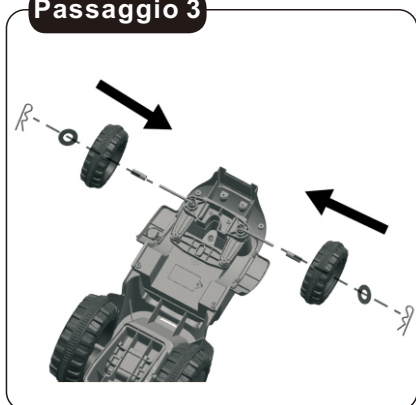

3. Montare le due ruote anteriori, inserire l'anello di plastica, la ruota e la rondella, fissare con un perno di cotter.

Passaggio 4

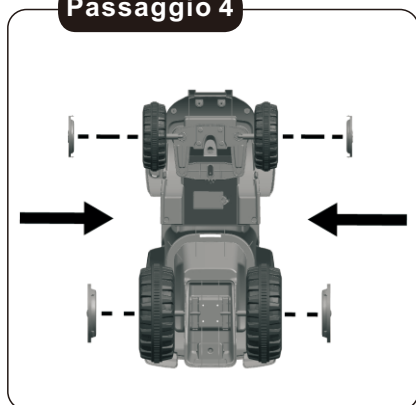

4. Posizionare i due coperchi delle ruote anteriori nelle ruote anteriori e i due coperchi delle ruote posteriori nelle ruote posteriori.

Passaggio 5

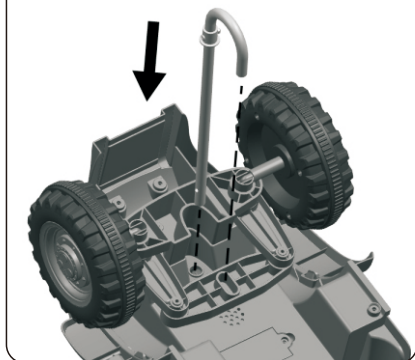

5. Installare il bastoncino a forma J nella posizione assegnata come mostrato nell'immagine.

Passaggio 6

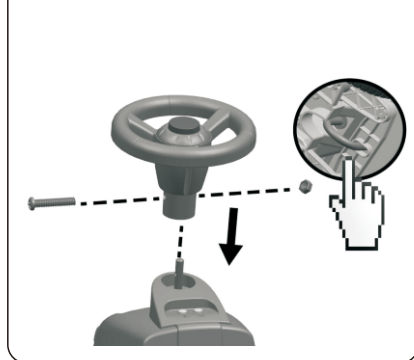

6. Allentare prima il bullone e il dado nel volante, e poi posizionare il volante sul bastoncino a forma J, inserire il bullone e stringere il dado con un cacciavite (non incluso).
and tighten the nut with a screwdriver(not included)

Passaggio 7



7. Montare il sedile, stringere con una vite nera da un cacciavite (non incluso).

Passaggio 8



8. Inserire il tubo di scarico, assicurarsi che il tubo di scarico sia completamente piantato.

Assemblaggio Trattore

Passaggio 1

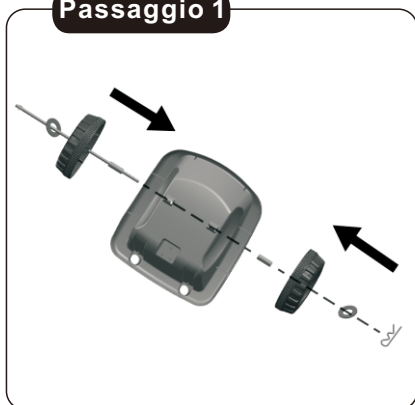

1. Inserire l'asse della ruota attraverso la rondella, montare la ruota del rimorchio, l'anello di plastica nel rimorchio, fissare con una coppia.

Passaggio 2

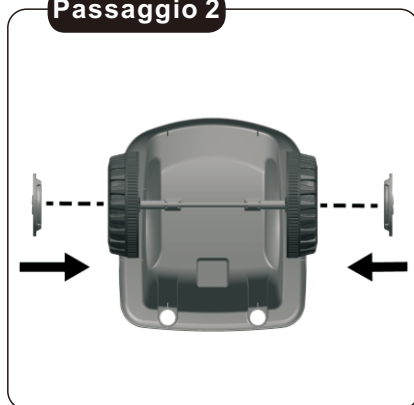

2. Posizionare i due coperchi delle ruote anteriori nelle due ruote del rimorchio.

Passaggio 3

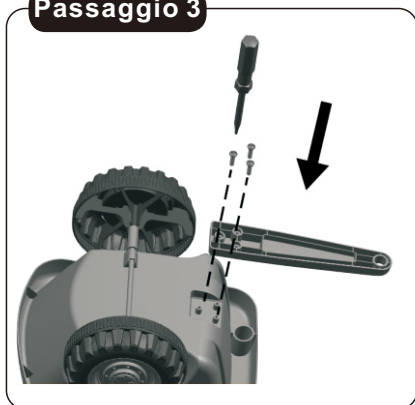

3. Montare il connettore del rimorchio con tre viti d'argento da un cacciavite (non incluso).

Passaggio 4

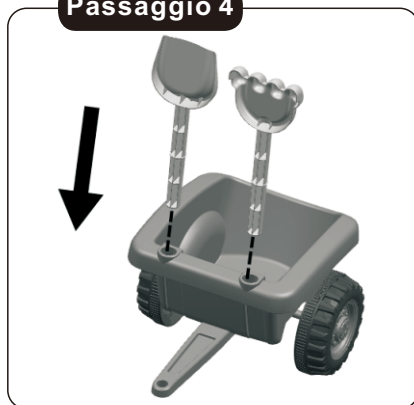

4. Inserire i due giocattoli nei fori del rimorchio.

Passaggio 5

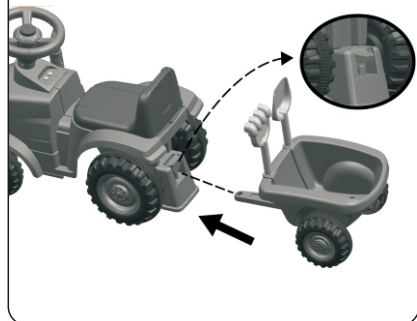

5. Aprire la serratura e collegare il rimorchio con il trattore.

Sostituzione della batteria

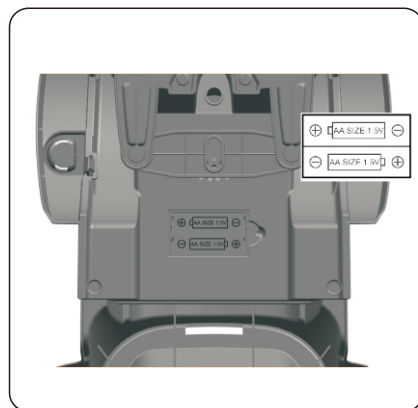
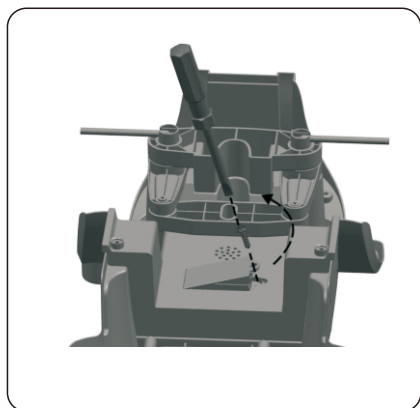

Capovolgere il corpo del trattore e trovare il vano della batteria. Allentare la vite con un cacciavite (non incluso). Sostituire con 2 batterie AA nel vano, e poi serrare la vite con un cacciavite (non incluso).

Funzionamento

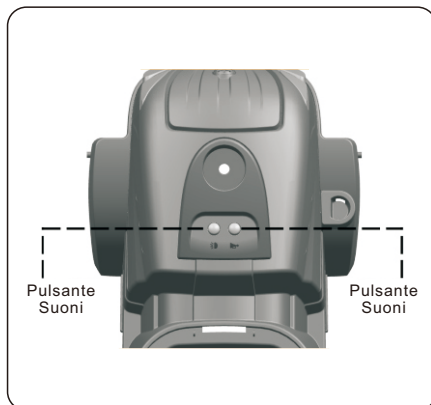
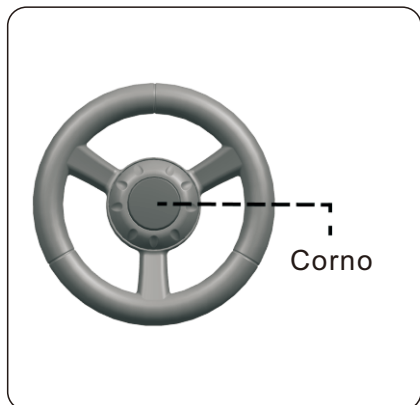

In caso di dubbio, si prega di contattare il nostro centro assistenza clienti. I nostri dettagli di contatto sono di seguito:

 0039-0249471447

 clienti@aosom.it

IMPORTATO DA/Produttore/REP:
AOSOM Italy srl
Centro Direzionale Milanofiori
Strada 1 Palazzo F1
20057 Assago (MI)
P.I.: 08567220960
FATTO IN CINA



***Adecuado para los niños de 12 a 36 meses .**

***Peso máximo: 25 kg.**



New Holland Construction es una marca registrada propiedad de CNH Industrial N.V., en la que CNH Industrial Italian S.p.A. tiene intereses de propiedad, y la marca es utilizada por Ningbo Prince Toys Co.,Ltd. en este producto en virtud de un acuerdo de licencia suscrito con CNH Industrial Italian S.p.A.

IMPORTANTE, LEA Y GUARDE PARA FUTURAS REFERENCIAS.

INSTRUCCIONES DE MONTAJE



ADVERTENCIA:

1. Este producto es adecuado para niños a partir de los 12-36 meses;
2. Este producto puede tener bordes afilados, puntas o piezas pequeñas antes del montaje y debe ser ensamblado por adultos;
3. Los niños deben montar esto en una superficie plana y lisa y mantenerse alejados de la carretera; Está estrictamente prohibido cerca de vehículos motorizados, calles, escalones, pendientes, colinas, carreteras, callejones, piscinas u otros lugares con agua;
4. Este producto debe ser utilizado bajo la supervisión de adultos y se deben usar zapatos;
5. Este producto está limitado a un solo pasajero, con una capacidad de carga máxima de 25 kg;
6. Se requiere el montaje y la instalación de todas las partes por parte de un adulto.
7. No permita que los niños jueguen solos con este producto para evitar peligros de caída.
8. El juguete debe usarse con precaución, ya que se requiere habilidad para evitar caídas o colisiones que puedan causar lesiones al usuario o a terceros.
9. Asegúrese de que este automóvil esté montado de manera correcta antes de utilizarlo.





MANTENIMIENTO Y CUIDADO

- A. Guarde todas las instrucciones y piezas relativas juntas con este producto para las referencias futuras.
- B. Compruebe regularmente para asegurarse de que no haya daños y que todos los tornillos estén apretados firmemente.
- C. Compruebe que el asiento del scooter esté abrochado firmemente.
- D. Limpieza: Limpiar únicamente la superficie con un paño seco.
- E. Almacenamiento: Mantenga el triciclo alejado del fuego, la humedad y otras áreas de alta temperatura. Evitar la exposición directa al sol.

Manejar las baterías:

1. Las baterías solo deben ser manipuladas por los adultos.
2. Siempre retire las baterías agotadas.
3. No mezcle las baterías viejas y nuevas.
4. No mezcle las baterías alcalinas, estándar (carbono-zinc) o recargables (níquel-cadmio).
5. No cargue las baterías no recargables.
6. Antes de cargar las baterías recargables, retírelas del automóvil.
7. Al cargar las baterías, se requiere la supervisión de un adulto responsable.
8. Inserte las baterías con los electrodos correctamente conectados.
9. Asegúrese de que los terminales de alimentación no estén en cortocircuito.
10. Las baterías recargables solo han de cargarse bajo supervisión de un adulto.
11. No deseche las baterías al fuego, de lo contrario, las baterías podrían explotar o tener fugas.
12. Se recomiendan utilizar las baterías alcalinas.
13. Cuando no utilice el automóvil durante largo plazo, retire las baterías.
14. Al reemplazar las baterías, asegúrese de reemplazar todas las baterías usadas por otras nuevas.
15. Solo utilice las baterías AA.

LISTA DE COMPONENTES

<p>1. Cuerpo 1pieza</p> 	<p>2. Volante 1pieza</p> 	<p>3. Remolque 1pieza</p> 
<p>4. Asiento 1pieza</p> 	<p>5. Tubo de escape 1pieza</p> 	<p>6. Rueda delantera 2piezas</p> 
<p>7. Tapa de la rueda trasera 2piezas</p> 	<p>8. Rueda trasera 2piezas</p> 	<p>9. Rueda de remolque 2piezas</p> 
<p>10. Tapa de rueda delantera 4piezas</p> 	<p>11. Armazón anti-vuelco 1pieza</p> 	<p>12. Conector de remolque 1pieza</p> 
<p>13. Palo en forma de J 1pieza</p> 	<p>14. Eje de rudas 2piezas</p> 	<p>15. Anillo 6piezas</p> 
<p>16. Arandela 7piezas (1 pieza de repuesto)</p> 	<p>17. Claveta 5piezas (1 pieza de repuesto)</p> 	<p>18. Tornillo negro 2piezas (1 pieza de repuesto)</p> 
<p>19. Tornillo plateado 4piezas (1 pieza de repuesto)</p> 	<p>20. Juguete 2piezas</p> 	

Ensamblaje del Tractor

Paso 1

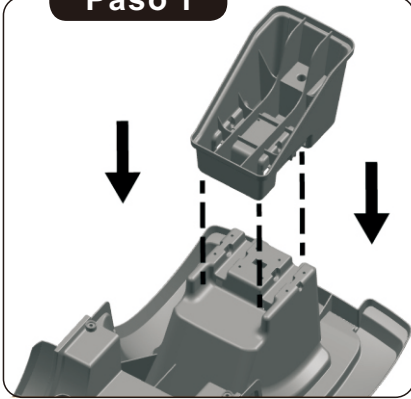

1. Coloque el armazón anti-vuelco detrás del cuerpo del tractor.

Paso 2

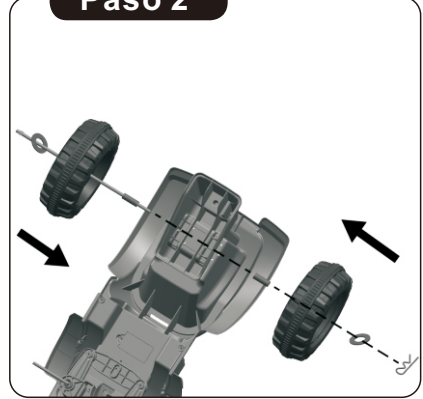

2. Inserte el eje de la rueda a través de la arandela, la rueda trasera, el anillo de plástico en el cuerpo, apriételo con una chaveta

Paso 3

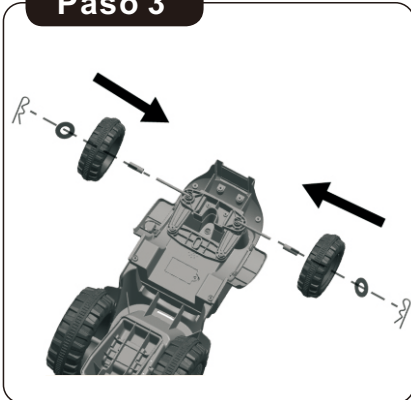

3. Monte las dos ruedas delanteras, inserte el anillo de plástico, la rueda y la arandela, y apriételos con una chaveta.

Paso 4

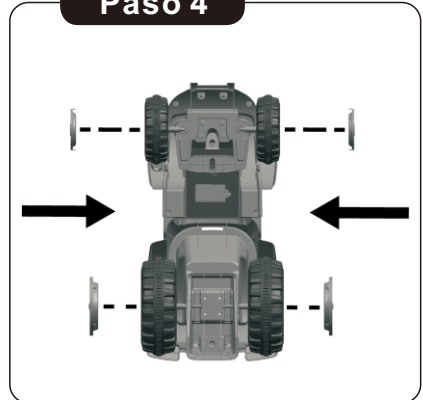

4. Coloque las dos tapas de las ruedas delanteras en las ruedas delanteras, y las dos tapas de las ruedas traseras en las ruedas traseras.

Paso 5

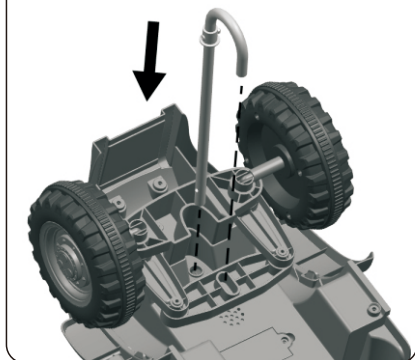

5. Instale el palo en forma de J en el lugar asignado como en la imagen.

Paso 6

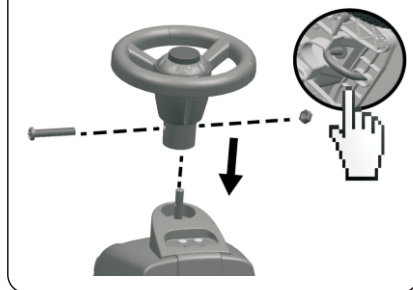

6. Afloje primero el tornillo y la tuerca en el volante, luego coloque el volante sobre el palo en forma de J, inserte el tornillo y apriete la tuerca con un destornillador (no incluido)

Paso 7



7. Monte el asiento, y apriete el tornillo negro con un destornillador (no incluido).

Paso 8



8. Inserte el tubo de escape, asegúrese de que el tubo de escape esté completamente asentado.

Ensamblaje del Tractor

Paso 1

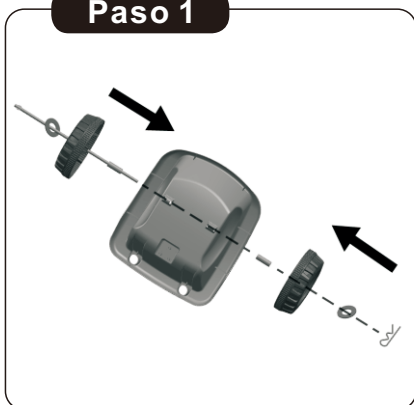

1. Inserte el eje de la rueda a través de la arandela, la rueda del remolque, el anillo de plástico en el remolque, apriételo con una claveta.

Paso 2

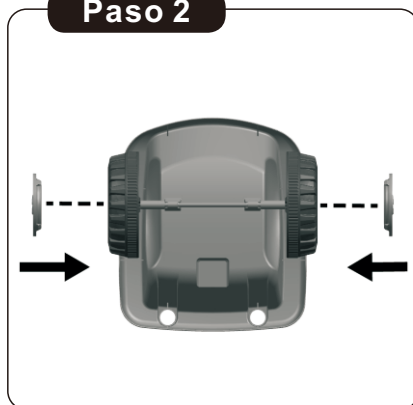

2. Coloque las dos tapas de las ruedas delanteras en las dos ruedas del remolque.

Paso 3

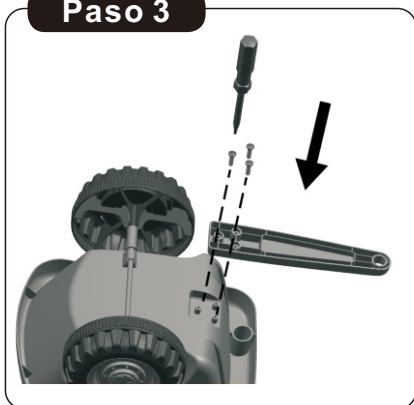

3. Monte el conector del remolque con tres tornillos plateados usando un destornillador (no incluido)

Paso 4



4. Inserte los dos juguetes en los agujeros del remolque.

Paso 5

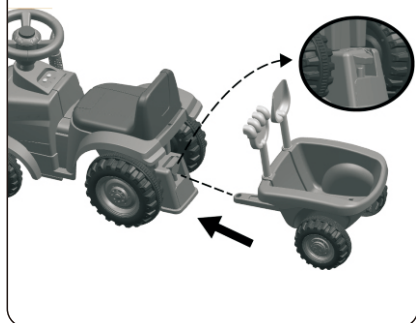

5. Abra la cerradura y conecte el remolque con el tractor.

Reemplazo de pilas

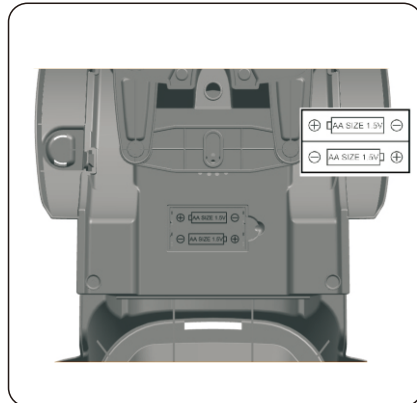
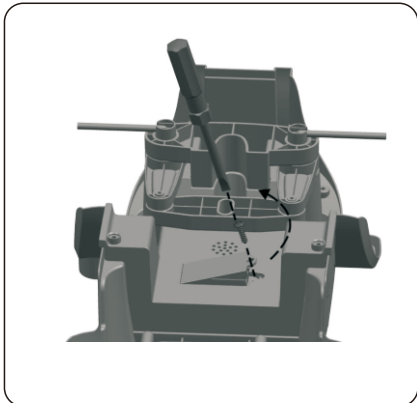

Gire el cuerpo del tractor y localice el compartimento de las pilas. Afloje el tornillo con un destornillador (no incluido). Coloque 2 pilas AA en el compartimento de las pilas y apriete el tornillo con un destornillador (no incluido).

Función

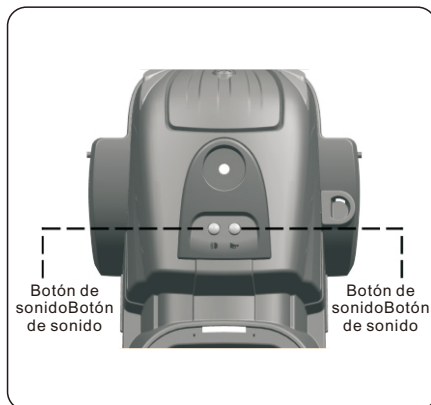
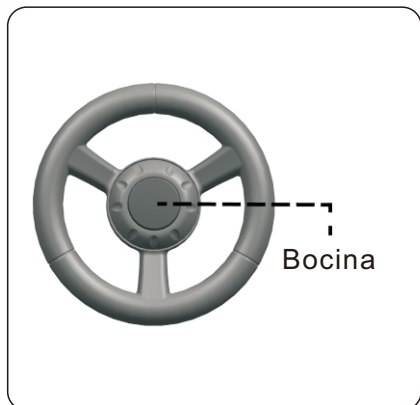

Si tiene alguna pregunta, comuníquese con nuestro Centro de Atención al Cliente.

Nuestros datos de contacto son los siguientes:

 0034-931294512

 atencioncliente@aosom.es

Importador/Fabricante/REP:

Spanish Aosom, S.L.

C/ Roc Gros, nº 15. 08550, Els Hostalets de Balenyà, Spain.

B66295775

atencioncliente@aosom.es

TEL: 931294512

HECHO EN CHINA

