

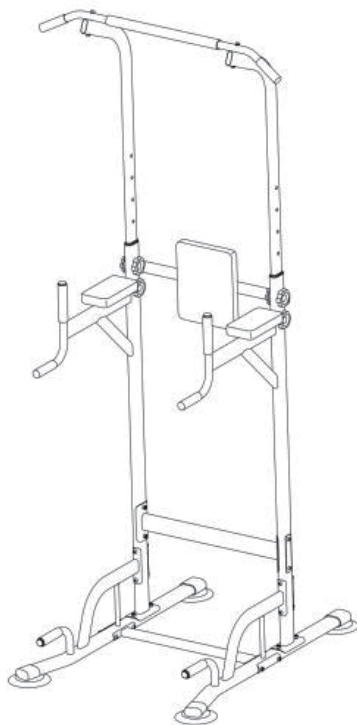

IN240200170V01\_UK\_FR\_ES\_PT\_IT\_DE

**A91-106**

**EN**



## Heavy Duty Adjustable Power Tower

IMPORTANT, RETAIN FOR FUTURE REFERENCE: READ CAREFULLY

**ASSEMBLY INSTRUCTIONS**

# WARNING DECAL PLACEMENT

This drawing shows the location(s) of the warning decal(s). If a decal is missing or illegible, see the front cover of this manual and request a free replacement decal. Apply the decal in the locations shown. Note: The decal(s) may not be shown at actual size

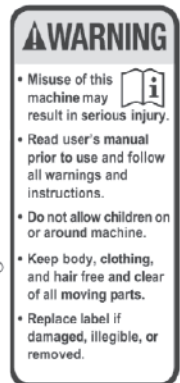
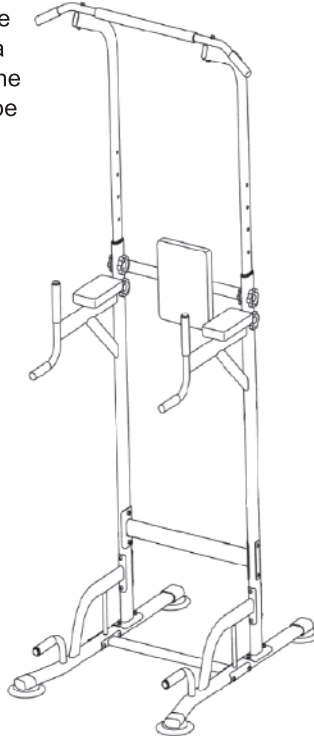

## CAUTION

Read all precautions and instructions in this manual before using this equipment. Keep this manual for future reference.

# IMPORTANT PRECAUTIONS

**WARNING:** To reduce the risk of serious injury, read all important precautions and instructions in this manual and all warnings on your exercise rack before using your exercise rack. assumes no responsibility for personal injury or property damage sustained by or through these of this product.

1. It is the responsibility of the owner to ensure that all users of the exercise rack are adequately informed of all precautions.
2. Before beginning any exercise program, consult your physician. This is especially important for persons over the age of 35 or persons with pre-existing health problems.
3. Use the exercise rack only as described in this manual.
4. The exercise rack is intended for home use only. Do not use the exercise rack in a commercial, rental, or institutional setting.
5. Keep the exercise rack indoors, away from moisture and dust. Do not put the exercise rack in a garage or covered patio, or near water.
6. Use the exercise rack only on a level surface. Cover the floor beneath the exercise rack to protect the floor.
7. Make sure that all parts are properly tightened each time the exercise rack is used. Replace any worn parts immediately.
8. Keep children under age 12 and pets away from the exercise rack at all times.
9. The exercise rack is designed to support a maximum user weight of 120KG.
10. Always wear athletic shoes for foot protection while exercising.
11. Over exercising may result in serious injury or death. If you feel faint or if you experience pain while exercising, stop immediately and cool down.

Consult your physician before starting this or any exercise program. This is especially important if you are over the age of 35, have never exercised before, are pregnant, or suffer from any health problem. This product is for home use only. Do not use in institutional or commercial applications. Failure to follow all warnings and instructions could result in bodily injury and property damage. To reduce the risk of serious injury, read the following Safety Instructions before using the rack.

# BEFORE YOU BEGIN

Thank you for selecting the versatile POWER TOWER exercise rack. The POWER TOWER exercise rack is designed to help you develop the major muscle groups of the upper body. Whether your goal is a shapely figure, dramatic muscle size and strength, or a healthier cardiovascular system, the exercise rack will help you achieve the specific results you want.

reading this manual, please see the front cover of this manual.

Before reading further, please review the drawing below and familiarize yourself with the parts that are labeled.

For your benefit, read this manual **carefully** before using the exercise rack. If you have questions after

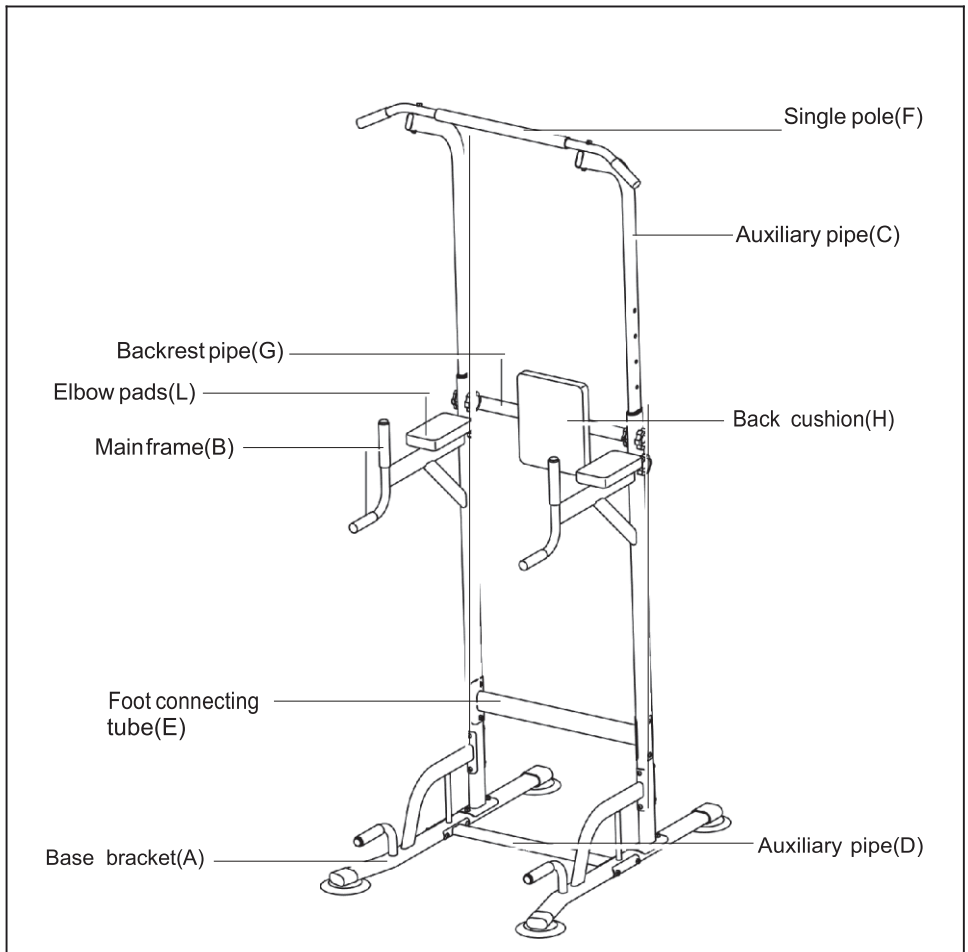









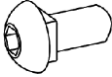



# PART IDENTIFICATION CHART

Use the drawings below to identify the small parts needed for assembly. The number in parentheses below each drawing is the key number of the part.



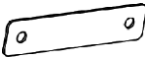

Note: If a part is not in the hardware kit, check to see if it has been preassembled. Extra parts may be included.

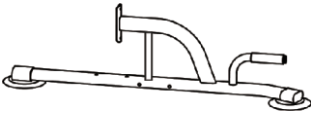

Please make a classification of the accessories first ,which is very important! Place all parts from the box in a cleared area and position them on the floor in front of you. Remove all packing materials from your area and place them back into the box. Do not dispose of the packing materials until assembly is completed. Read each step carefully before beginning.

Parts list	Name	picture	specification	Quantity
1	Round head square neck screw		M8*40	4
2	Inner hexagonal screw		M8*70	8
3	Inner hexagonal screw		M8*80	2
4	Inner hexagonal screw		M8*40	4
5	Inner hexagonal screw		M8*15	2
6	Plastic handle screw		M8*45	4
7	Plastic handle nut		M8	4
8	M8 nut		M8	18

Parts list	Name	picture	specification	Quantity
9	Arc backing plate		13*3	4
10	Reinforced backing plate		13*3	2
11	Circular gasket		68	6
12	Arc gasket		68	4
13	hexagonal installation too		5#	1
14	wrench		10#-13#	1

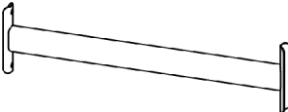
## ACCESSORIES DETAILS

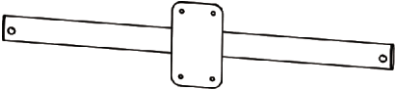
	Name	picture	Quantity
A	Base bracket		2
B	Main frame		2
C	Auxiliary pipe		2
D	Auxiliary pipe		1
E	Foot connecting tube		1

	Name	picture	Quantity
F	Single pole		1
G	Backrest pipe		1
H	Back cushion		1
L	Elbow pads		2

## ASSEMBLY

After confirming the integrity of all accessories, start installation  
**NOTE : PLEASE DO NOT SECURELY TIGHTEN ALL BOLTS UNTIL STEP 9.**

### Step 1

- ① Identify the left and right base(A)

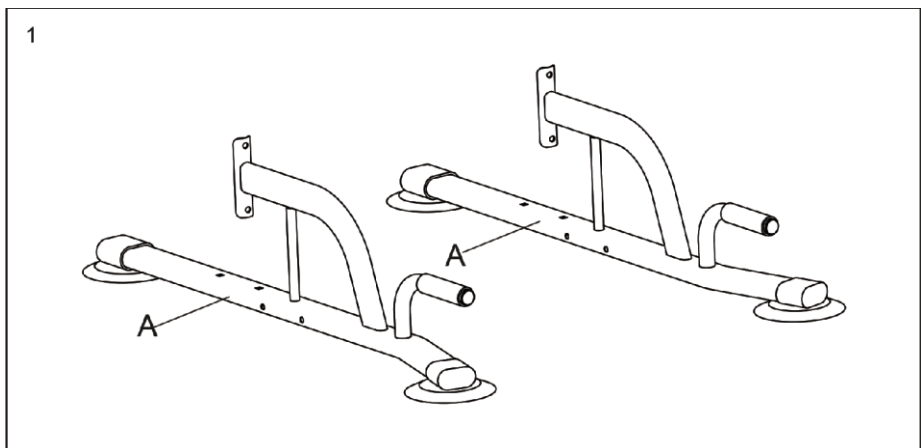

## Step 2 Connect Base (A) and Foot Pipe (D)

- ① Connect the two foot tubes (D) and base (A) with the four M8\*70 inner hexagonal screws (2) then, tighten arc plate (9) to them with M8 (8) locknuts.

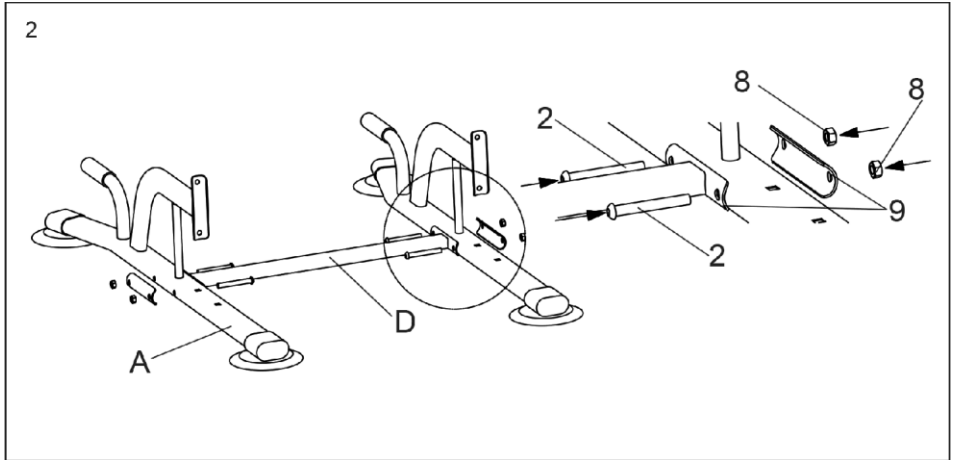

## Step 3 Install Main Frame

- ① Find main frame(B) 2 pieces with 4 M8 \* 40 round head square neck screws(1) from bottom through base(A) Put round gasket 11, tighten with M8 nut(8)
- ② Use 4 M8 \* 70 inner hexagonal screws(2) from the base(A) to connect to the main frame and put on the curved pad(9) and tighten with the M8 nut(8)

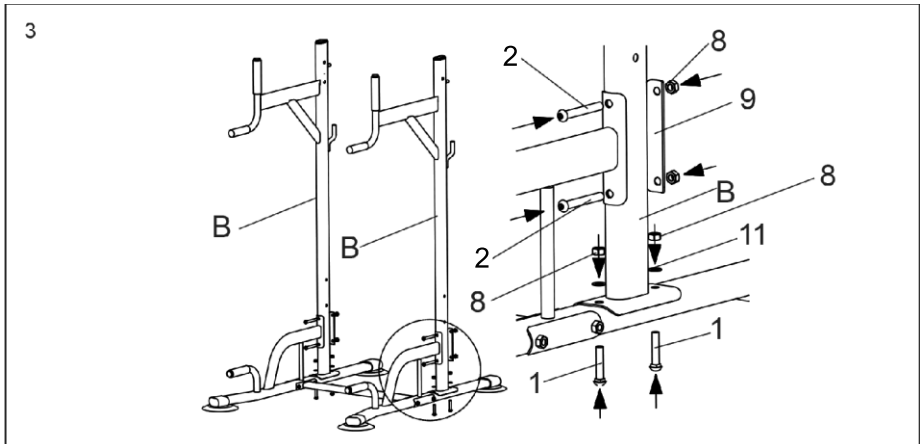

## Step 4 Install Main Frame

- ① Find the supervisor joint(E) with 4 M8 \* 40 inner hexagonal screws(4), connect with the main frame(B) put the reinforcement pad(10) through from the outside, and tighten with the M8 nut(8).

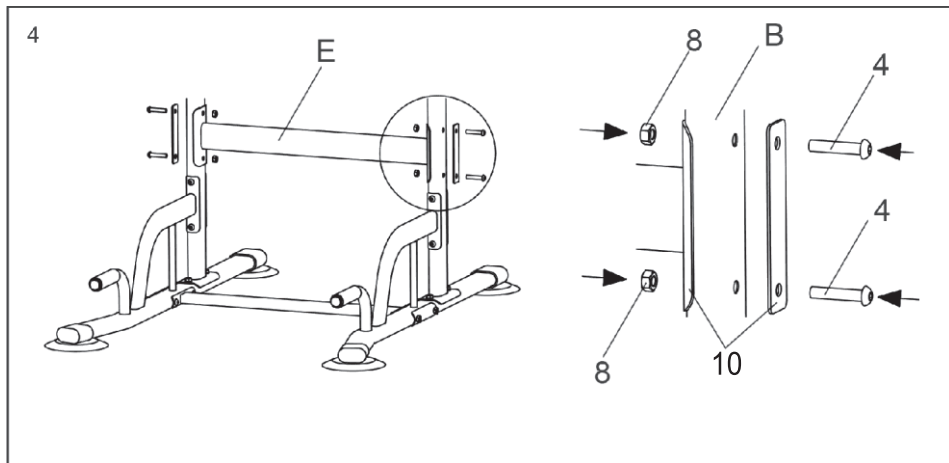

## Step 5 Install Elbow Pad(L)

- ① Fasten through the iron plate and elbow pad(L) with the self-propelled screw on the main frame(B)

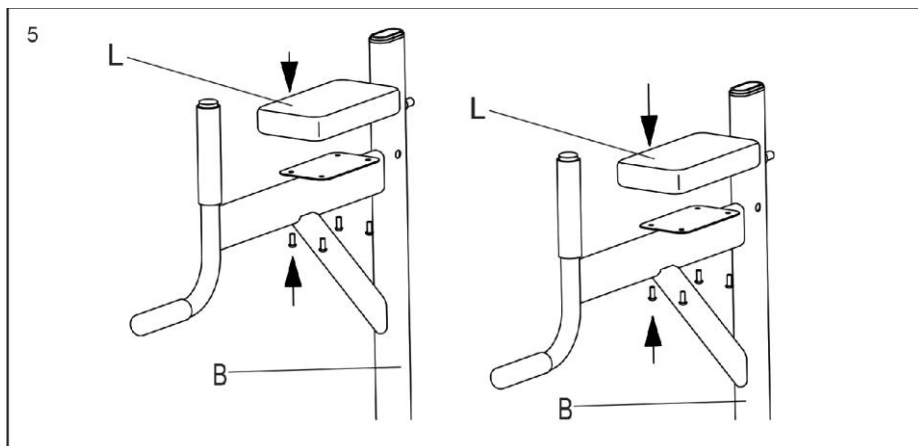

## Step 6 Installation of cushions(H)

- ① Attach the backrest pad (H) to the backrest pipe(G) with the screws of the backrest pipe(G).

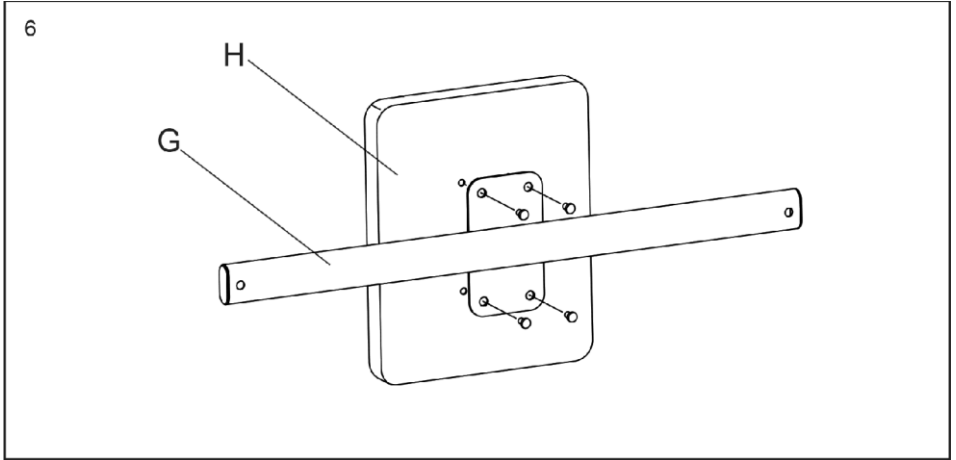

## Step 7 Install backend(C)

- ① Attach the backrest tube (G) to the main frame (B) with the M8\*15 inner hexagonal screw (5) then, tighten round plate(11) to them with the inner hexagonal wrench.

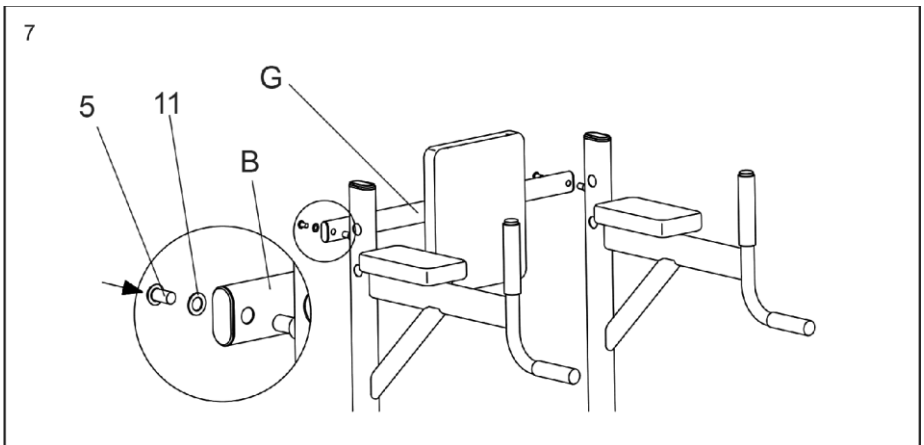

## Step 8 Install single bar(F)

- ① Attach the single rod (F) to the auxiliary pipe (C) with M8\*80 inner hexagonal screws (3) then, tighten arc plate(12) to them with M8 (8) locknuts. Note: Orient the Screw holes

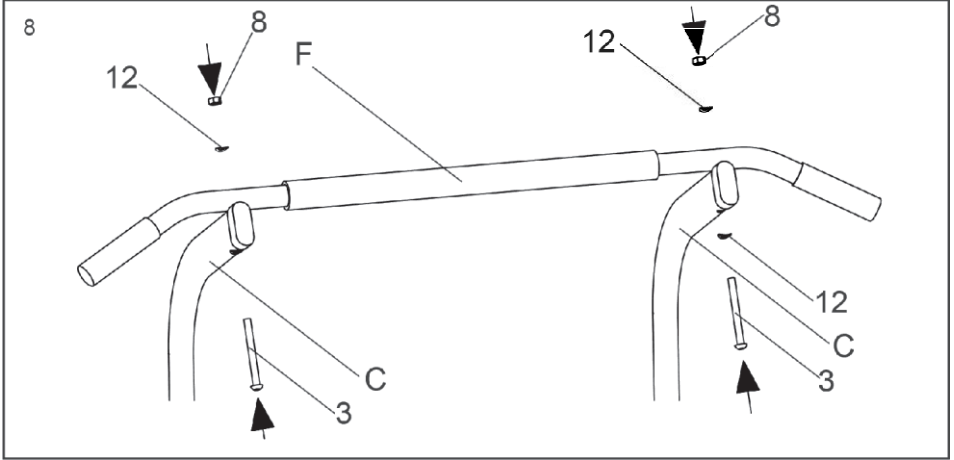

## Step 9 Install Deputy(C)

- ① Put the auxiliary pipe(c) through top of the main frame(B) and adjust the proper height to orient the screw holes then, tighten M8\*45 plastic handle screw(6) to them with plastic handle nuts (7).

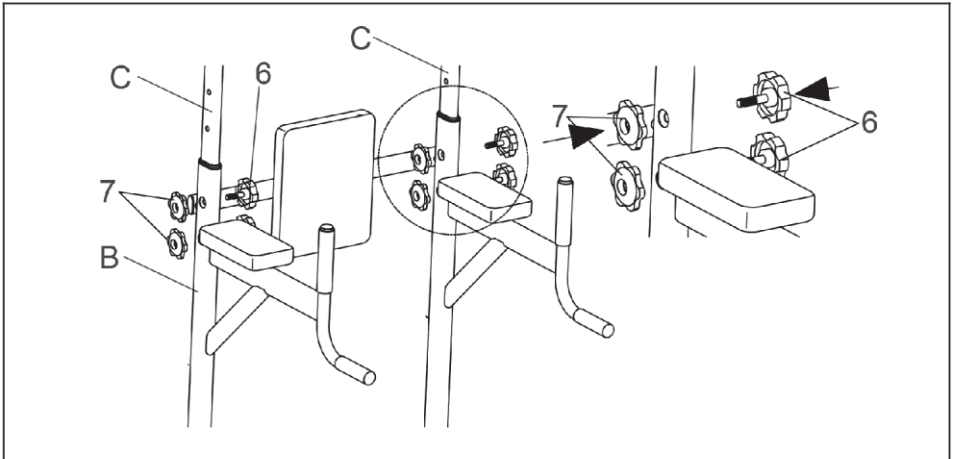

# INSTALLATION COMPLETE

10

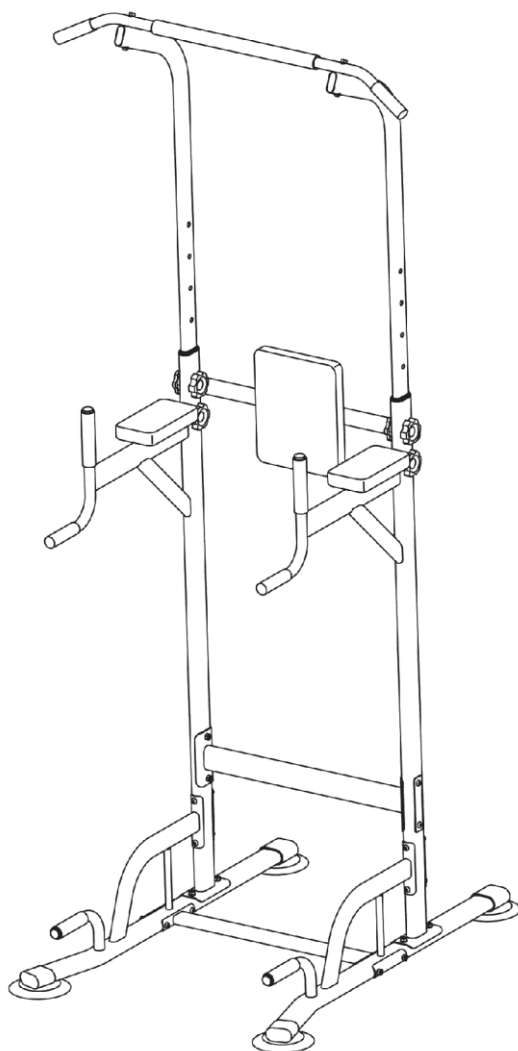

# EXPLODED DRAWING

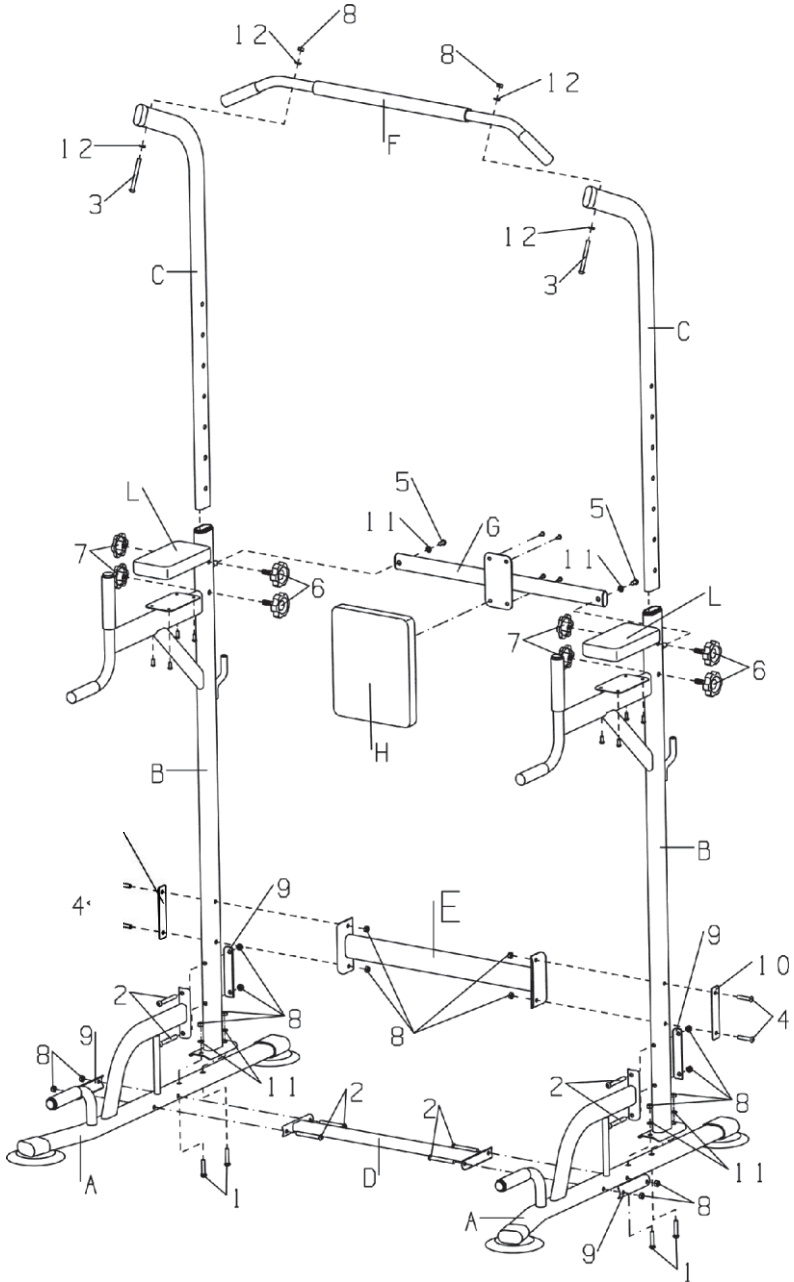

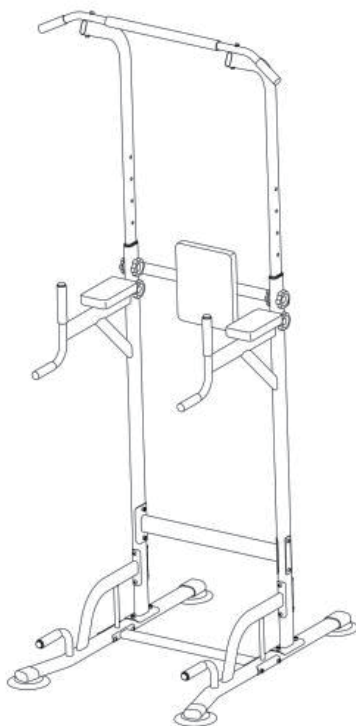

## Tour de puissance ajustable et robuste

**IMPORTANT - CONSERVEZ CES INFORMATIONS  
POUR VOTRE CONSULTATION ULTÉRIEURE: LISEZ ATTENTIVEMENT**

**INSTRUCTIONS D'ASSEMBLAGE**

## EMPLACEMENT DE L'AUTOCOLLANT D'AVERTISSEMENT

Ce dessin indique l'emplacement du ou des autocollants d'avertissement. Si un autocollant est manquant ou illisible, voir la couverture de ce manuel et demander un autocollant de remplacement gratuit. Appliquez l'autocollant à l'endroit indiqué. Remarque : il se peut que le(s) autocollant(s) ne soit(nt) pas représenté(s) dans sa(leur) taille réelle.

### AVERTISSEMENT

POIDS DE L'UTILISATEUR :  
MAX 120KG

Lisez toutes les précautions et instructions dans ce manuel avant d'utiliser cet équipement. Le produit peut ne pas offrir tous les exercices répertoriés

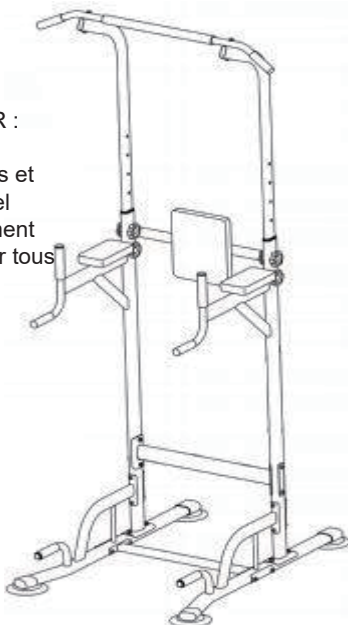

### AVERTISSEMENT

- Faible hauteur sous plafond.
- Pour éviter les blessures à la tête, positionnez correctement votre corps.

### AVERTISSEMENT

- Une utilisation incorrecte de cette machine peut entraîner des blessures graves.
- Lisez le manuel de l'utilisateur avant utilisation et suivez toutes les instructions et avertissements.
- Ne laissez pas les enfants sur ou autour de la machine.
- Gardez le corps, les vêtements et les cheveux loin de toutes les pièces mobiles.
- Remplacez l'étiquette si elle est endommagée, illisible ou retirée.

## ATTENTION

Lisez toutes les précautions et instructions dans ce manuel avant d'utiliser cet équipement. Conservez ce pour référence ultérieure.

## PRÉCAUTIONS IMPORTANTES

**AVERTISSEMENT :** Pour réduire le risque de blessures graves, lisez toutes les précautions importantes et instructions dans ce manuel et tous les avertissements sur votre rack d'exercice avant d'utiliser votre rack d'exercice. n'assume aucune responsabilité pour les blessures personnelles ou les dommages matériels subis par l'utilisation de ce produit.

1. Il incombe au propriétaire de veiller à ce que tous les utilisateurs du rack d'exercice soient suffisamment informés de toutes les précautions.
2. Avant de commencer un programme d'exercices, consultez votre médecin. Cela est particulièrement important pour les personnes de plus de 35 ans ou les personnes ayant des problèmes de santé préexistants.
3. Utilisez le rack d'exercice uniquement comme décrit dans ce manuel.
4. Le rack d'exercice est destiné à un usage domestique uniquement. N'utilisez pas le rack d'exercice dans un environnement commercial, de location ou institutionnel.  
Gardez le rack d'exercice à l'intérieur, à l'abri de l'humidité et de la poussière. Ne placez pas le rack d'exercice dans un garage ou sur un patio couvert, ou près de l'eau
6. Utilisez le rack d'exercice uniquement sur une surface plane. Couvrir le sol sous le rack d'exercice pour protéger le sol.
7. Assurez-vous que toutes les pièces sont correctement serrées à chaque utilisation du rack d'exercice. Remplacez immédiatement toute pièce usée.
8. Gardez les enfants de moins de 12 ans et les animaux domestiques éloignés du rack d'exercice en tout temps.
9. Le rack d'exercice est conçu pour supporter un poids utilisateur maximum de 120KG
10. Portez toujours des chaussures de sport pour protéger vos pieds pendant l'exercice  
Faire trop d'exercice peut entraîner des blessures graves ou la mort. Si vous vous sentez étourdi ou si vous ressentez une douleur pendant l'exercice, arrêtez immédiatement et refroidissez-vous.

Consultez votre médecin avant de commencer ce programme d'exercices ou tout autre programme d'exercices. Cela est particulièrement important si vous avez plus de 35 ans, n'avez jamais fait d'exercice auparavant, êtes enceinte ou souffrez de tout problème de santé. Ce produit est destiné à un usage domestique uniquement. Ne pas utiliser dans des applications institutionnelles ou commerciales. Le non-respect de tous les avertissements et instructions pourrait entraîner des blessures corporelles et des dommages matériels. Pour réduire le risque de blessures graves, lisez les instructions de sécurité suivantes avant d'utiliser le rack.

## AVANT DE COMMENCER

Merci d'avoir choisi le rack d'exercices polyvalent POWER TOWER. Le rack d'exercices POWER TOWER est conçu pour vous aider à développer les principaux groupes musculaires du haut du corps. Que votre objectif soit une silhouette élégante, une taille et une force musculaire impressionnantes, ou un système cardiovasculaire plus sain, le rack d'exercices vous aidera à obtenir les résultats spécifiques que vous souhaitez.

Dans votre intérêt, lisez attentivement ce manuel avant d'utiliser le support d'exercices. Si vous avez des questions après avoir lu ce manuel, veuillez consulter la couverture de ce manuel. Avant de continuer à lire, veuillez examiner le dessin ci-dessous et vous familiariser avec les pièces qui sont étiquetées.

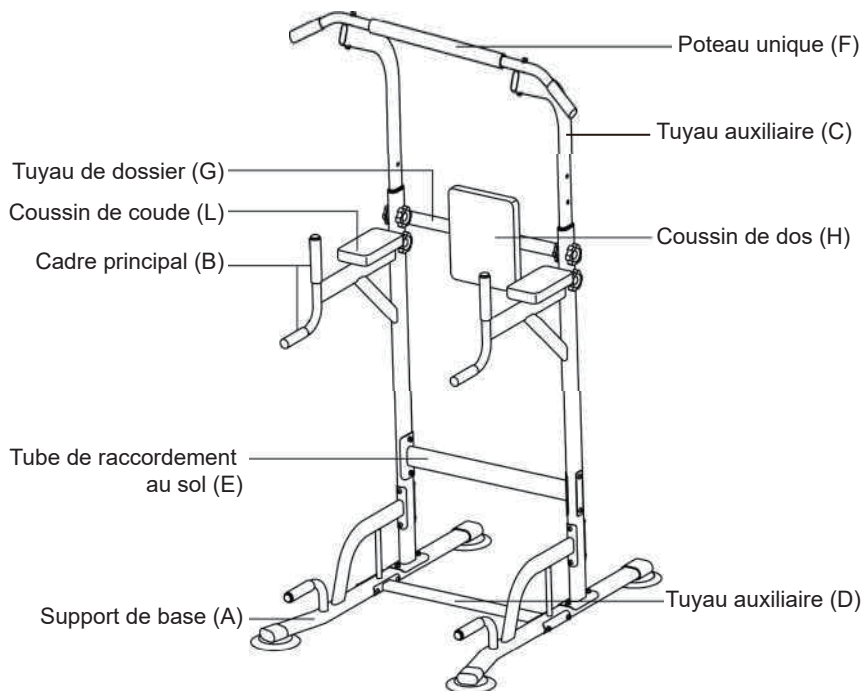















## TABLEAU D'IDENTIFICATION DES PIÈCES







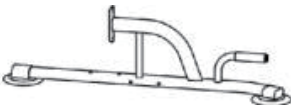

Utilisez les dessins ci-dessous pour identifier les petites pièces nécessaires à l'assemblage. Le nombre entre parenthèses sous chaque dessin est le numéro de clé de la pièce.

Remarque : Si une pièce n'est pas dans le kit de quincaillerie, vérifiez si elle a été préassemblée. Des pièces supplémentaires peuvent être incluses.

Veuillez classer d'abord les accessoires, ce qui est très important ! Placez toutes les pièces de la boîte dans une zone dégagée et positionnez-les sur le sol devant vous. Retirez tous les matériaux d'emballage de votre zone et replacez-les dans la boîte. Ne jetez pas les matériaux d'emballage avant que l'assemblage ne soit terminé. Lisez attentivement chaque étape avant de commencer.

Liste des pièces	Désignation	image	spécification	Quantité
1	Vis à tête carrée à tête ronde		Vis M8*40	4
2	Vis hexagonale intérieure		Vis M8*70	8
3	Vis hexagonale intérieure		Vis M8*80	2
4	Vis hexagonale intérieure		Vis M8*40	4
5	Vis hexagonale intérieure		Vis M8*15	2
6	Vis à poignée en plastique		M8*45	4
7	Vis à poignée en plastique		M8	4
8	Écrou M8		M8	18
9	Plaque de soutien arqué		13*3	4
10	Plaque de support renforcée		13*3	2
11	Joint circulaire		68	6
12	Joint arqué		68	4
13	Outil d'installation hexagonal		5#	1
14	Clé		10#-13#	1

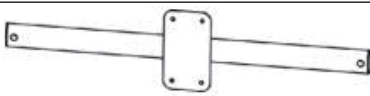
## DÉTAILS DES ACCESSOIRES

	Désignation	image	Quantité
A	Support de base	 A technical drawing of a base support component, featuring a horizontal base with a vertical post and a curved arm extending from the top.	2
B	Cadre principal	 A technical drawing of the main frame, showing a long horizontal beam with several holes and a T-shaped crosspiece at one end.	2
C	Tuyau auxiliaire	 A technical drawing of an auxiliary pipe, which is a long, thin tube with a slight curve at one end.	2
D	Tuyau auxiliaire	 A technical drawing of an auxiliary pipe with a straight shape and flared ends.	1
E	Tube de raccordement au sol	 A technical drawing of a ground connection tube, consisting of a long, straight tube with flared ends.	1
F	Poteau unique	 A technical drawing of a single post, a long, thin tube with a slight curve and a small protrusion at one end.	1
G	Tuyau de dossier	 A technical drawing of a backrest pipe, a long, straight tube with a central rectangular plate and holes.	1
H	Coussin de dos	 A technical drawing of a backrest cushion, a simple rectangular block.	1
L	Coussin de coude	 A technical drawing of an elbow cushion, a rectangular block with rounded ends.	2

## ASSEMBLAGE

Après avoir confirmé l'intégrité de tous les accessoires, commencez l'installation  
REMARQUE : NE SERREZ PAS TOUS LES BOULONS AVANT L'ÉTAPE 9.

Étape 1 :

① Identifiez les supports gauche et droit (A)

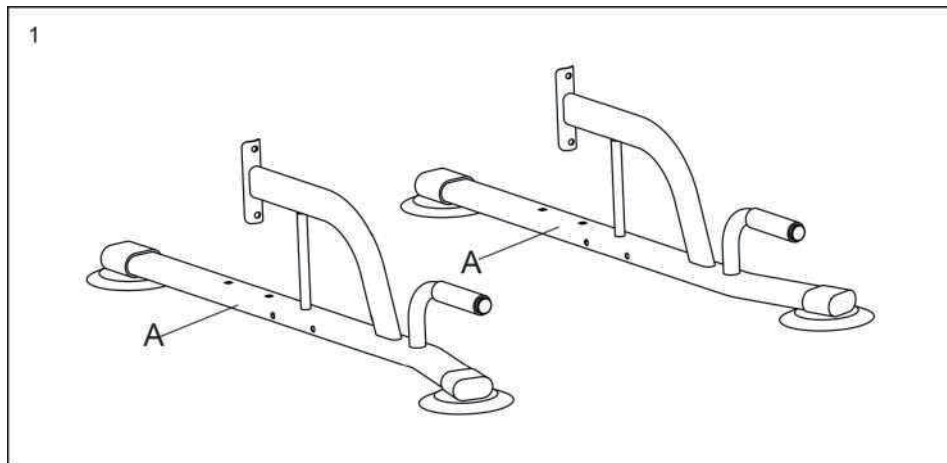

Étape 2 : Connectez le support (A) et le tuyau de pied (D)

① Connectez les deux tubes de pied (D) et la base (A) avec les quatre vis hexagonales intérieures M8\*70 (2) puis, serrez la plaque arquée (9) avec des écrous de blocage M8 (8).

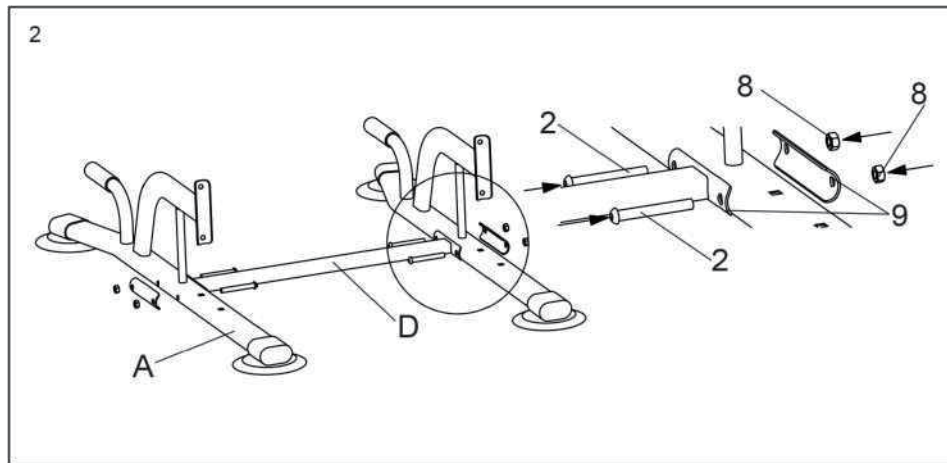

### Étape 3 : Installez le cadre principal

① Trouvez le cadre principal(B) avec 4 vis à tête carrée M8\*40 (1) par le bas à travers la base(A) Mettez la rondelle ronde 11, serrez avec un écrou M8(8)

② Utilisez 4 vis hexagonales intérieures M8\*70 (2) de la base(A) pour connecter au cadre principal et mettre le tampon courbé(9) et serrez avec l'écrou M8(8)

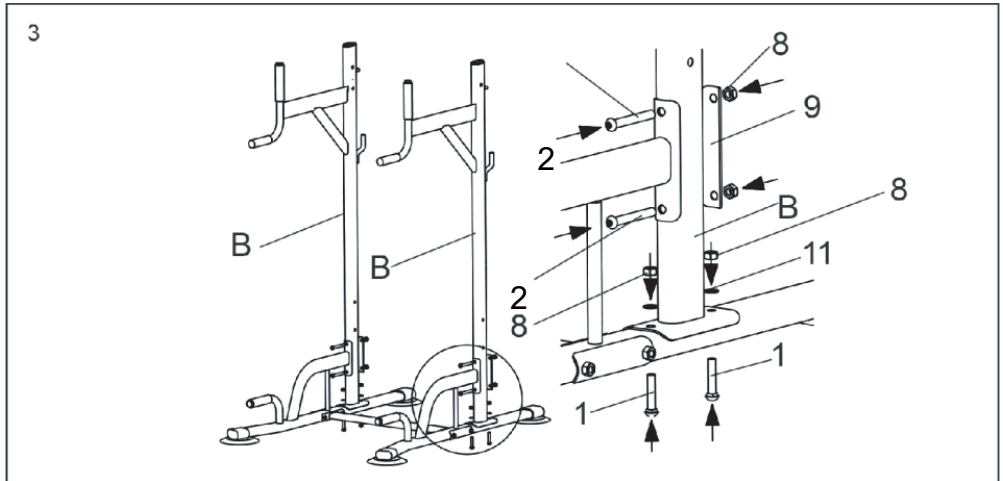

### Étape 4 : Installez le cadre principal

① Trouvez l'articulation de surveillance(E) avec 4 vis hexagonales intérieures M8\*40(4), connectez-vous au cadre principal(B) mettez la plaque de renfort(10) à travers de l'extérieur, et serrez avec l'écrou M8(8).

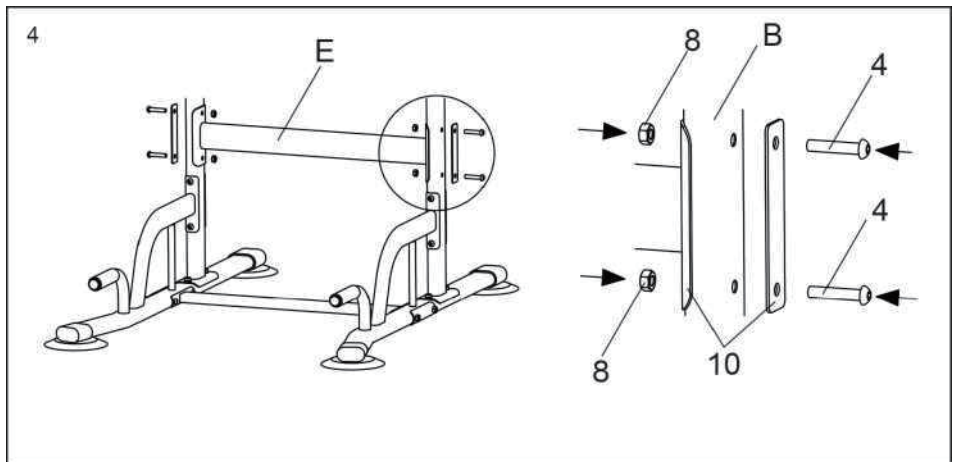

### Étape 5 : Installez le coussin de coude (L)

① Fixez à travers la plaque de fer et le coussin de coude (L) avec la vis auto-propulsée sur le cadre principal (B)

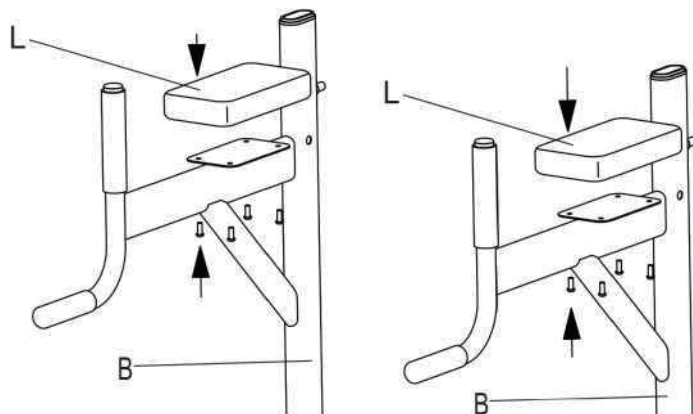

### Étape 6 : Installation des coussins (H)

① Fixez le coussin de dossier (H) au tuyau de dossier (G) avec les vis du tuyau de dossier (G).

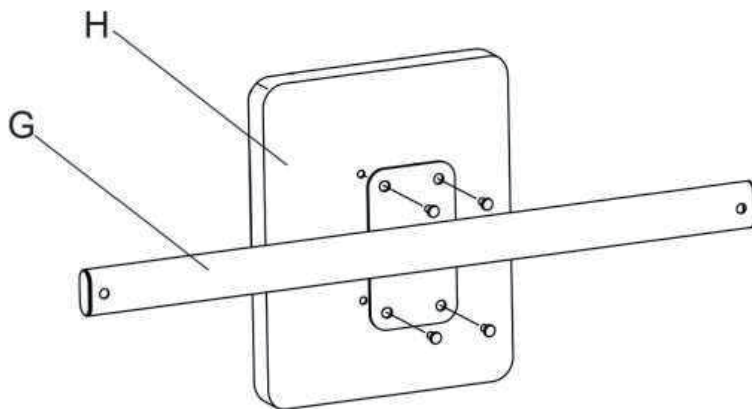

Étape 7 : Installez l'extrémité arrière (C)

① Fixez le tube de dossier (G) au cadre principal (B) avec la vis hexagonale intérieure M8\*15 (5) puis, serrez la plaque ronde (11) sur eux avec la clé hexagonale intérieure.

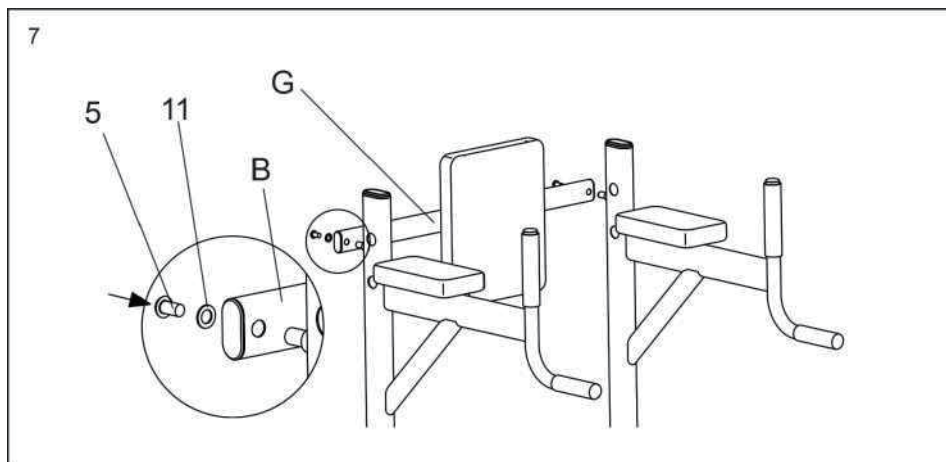

PÉtape 8 : Installez la barre unique (F)

① Attachez la barre unique (F) au tuyau auxiliaire (C) avec les vis hexagonales intérieures M8\*80 (3) puis, serrez la plaque arquée (12) sur eux avec des écrous de blocage M8 (8).  
Remarque : Orientez les trous de vis

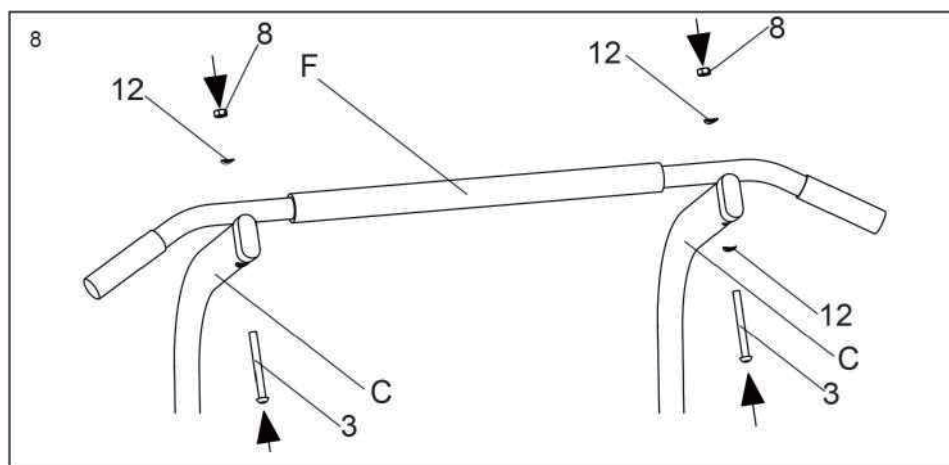

### Étape 9 : Installer le tuyau auxiliaire

① Mettez le tuyau auxiliaire(c) par le haut du cadre principal(B) et ajustez la hauteur appropriée pour orienter les trous de vis puis, serrez la vis à poignée en plastique M8\*45(6) sur eux avec des écrous à poignée en plastique (7).

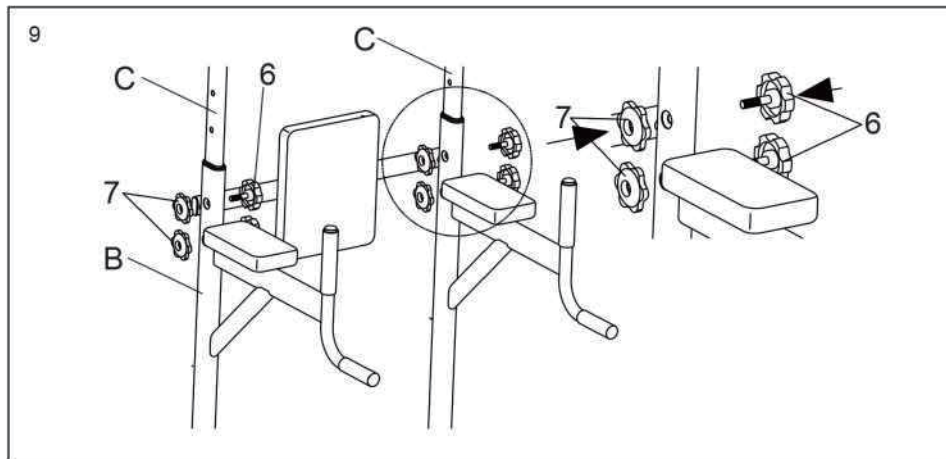

## INSTALLATION TERMINÉE

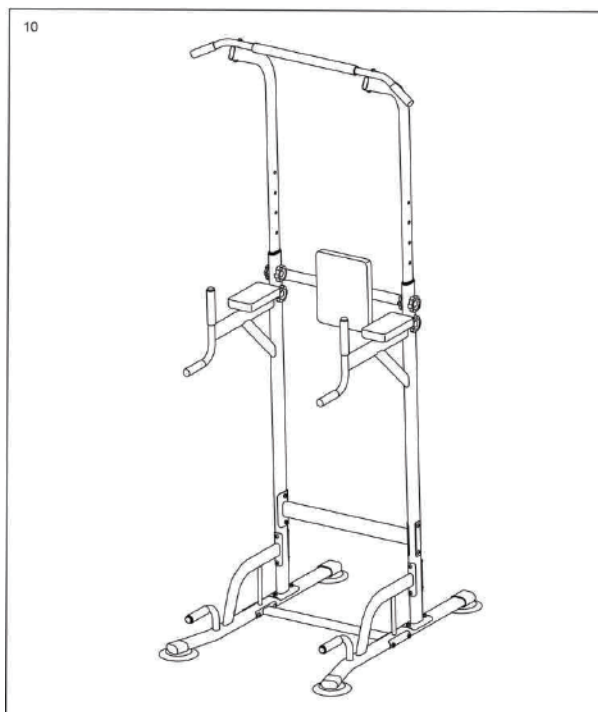

# DESSIN DÉTAILLÉ

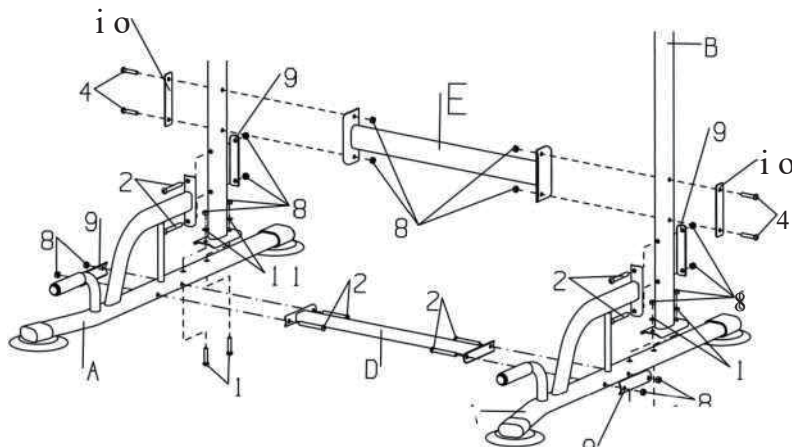
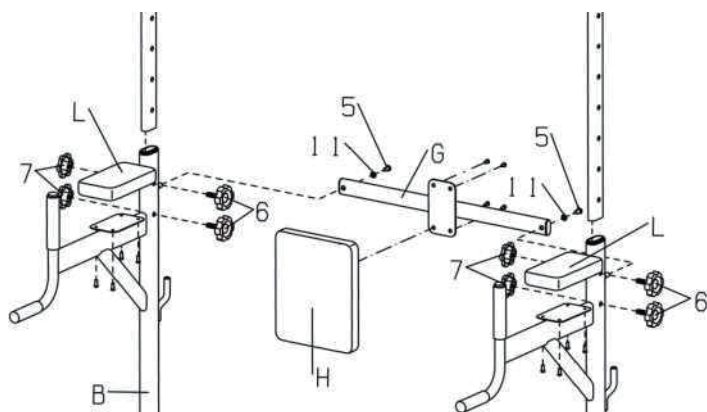
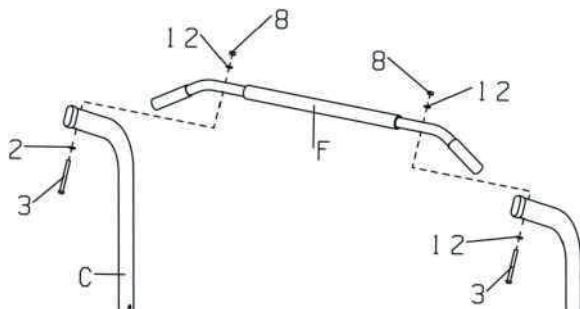

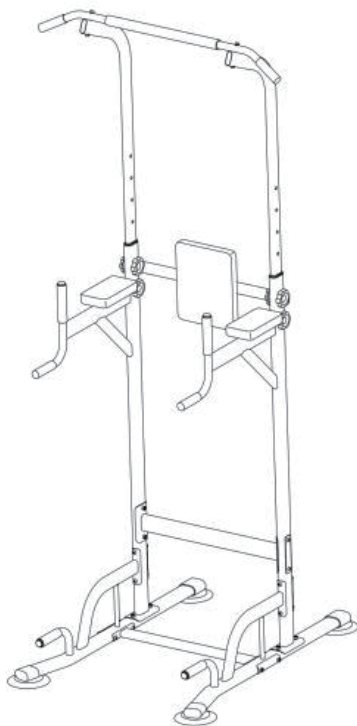

## Torre de Fuerza Ajustable para Trabajo Pesado

LEA Y GUARDE ESTA INSTRUCCIÓN PARA FUTURA REFERENCIA

# INSTRUCCIONES DE MONTAJE

# COLOCACIÓN DE LAS ETIQUETAS DE ADVERTENCIA

Este dibujo muestra la (s) ubicación (es) de la(s) etiqueta (s) de advertencia. Si falta alguna etiqueta o es ilegible, consulte la portada de este manual y solicite una etiqueta de reemplazo gratuita. Coloque la etiqueta en la ubicación mostrada.

Nota: Es posible que las etiquetas no se muestren en tamaño real.

## ADVERTENCIA

Peso del usuario: Max \* 120 KG

Lea todas las precauciones e instrucciones de este manual antes de utilizar este equipo. Es posible que en el producto no puede practicar todos los ejercicios enumerados.

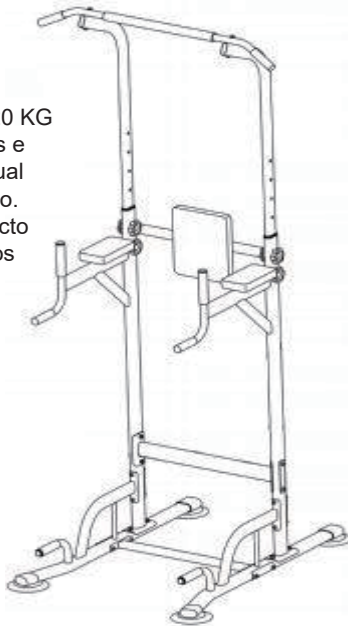

## ADVERTENCIA

Para evitar lesiones en la cabeza, mantenga el cuerpo en posición correcta.

## ADVERTENCIA

El mal uso de esta máquina puede resultar en lesiones graves.

Lea el manual del usuario antes de usarlo y siga todas las advertencias e instrucciones.

No permita que los niños se acerquen a la máquina o estén cerca de ella.

Mantenga el cuerpo, la ropa y el cabello libres y alejados de todas las piezas móviles.

Reemplace la etiqueta si está dañada, ilegible o caída.

## PRECAUCIÓN

Lea todas las precauciones e instrucciones de este manual antes de utilizar este equipo. Guarde este manual para su futura referencia.

## PRECAUCIONES IMPORTANTES

**ADVERTENCIA:** Para reducir el riesgo de lesiones graves, lea todas las precauciones e instrucciones importantes en este manual y todas las advertencias en su equipo de ejercicios antes de usarlo. Nuestra empresa no asume ninguna responsabilidad por lesiones personales o daños a la propiedad sufridos por o a través del uso de este producto.

- 1.El propietario tiene que asegurarse de que todos los usuarios del soporte de ejercicios estén adecuadamente informados de todas las precauciones.
- 2.Antes de comenzar cualquier programa de ejercicios, consulte a su médico para obtener sus sugerencias. Esto es especialmente importante para personas mayores de 35 años o personas con problemas de salud preexistentes.
- 3.Únicamente utilice el soporte de ejercicios como se describe en este manual.
- 4.El soporte de ejercicios está diseñado para uso doméstico únicamente. No utilice el soporte de ejercicios en un ambiente comercial, ni de alquiler o institucional.
- 5.Mantenga el soporte de ejercicios en el interior, alejado de la humedad y el polvo. No coloque el soporte de ejercicios en un garaje o patio cubierto, o cerca del agua.
- 6.Utilice el soporte de ejercicios sólo en una superficie nivelada. Cubra el piso debajo del soporte de ejercicios para proteger el piso.
- 7.Asegúrese de que todas las piezas estén bien apretadas cada vez que utilice el soporte de ejercicios. Reemplace la pieza desgastada inmediatamente cuando la detecta.
- 8.Mantenga a los niños menores de 12 años y las mascotas alejados del soporte de ejercicios en todo momento.
- 9.El soporte de ejercicios está diseñado para soportar un peso máximo de usuario de 120 KG.
- 10.Siempre utilice calzados deportivos para proteger los pies mientras hace ejercicio.
- 11.El ejercicio excesivo puede provocar lesiones graves o la muerte. Si siente maleo o dolor mientras hace ejercicio, deténgase inmediatamente y descanse.

Consulte a su médico antes de comenzar un programa de ejercicios. Esto es especialmente importante si tiene más de 35 años, nunca ha hecho ejercicio antes, o está embarazada o sufre algún problema de salud. Este producto es sólo para uso doméstico. No lo utilice en aplicaciones institucionales o comerciales. El incumplimiento de todas las advertencias e instrucciones podría resultar en lesiones corporales y daños a la propiedad. Para reducir el riesgo de lesiones graves, lea las siguientes instrucciones de seguridad antes de utilizar el soporte.

## ANTES DE EMPEZAR

Gracias por seleccionar el versátil soporte de ejercicios TORRE DE FUERZA.

El soporte de ejercicios TORRE DE FUERZA está diseñado para ayudarle a desarrollar los principales grupos de músculos de la parte superior del cuerpo. Ya sea que su objetivo sea tener una figura bien formada, un tamaño y fuerza muscular dramáticos o un sistema cardiovascular más saludable, el soporte de ejercicios lo ayudará a lograr los resultados específicos que desea.

Para su beneficio, lea este manual detenidamente antes de usar el soporte de ejercicios. Si tiene dudas después de leer este manual, consulte la portada de este manual. Antes de seguir leyendo el manual, revise el dibujo a continuación y familiarícese con las partes indicadas.

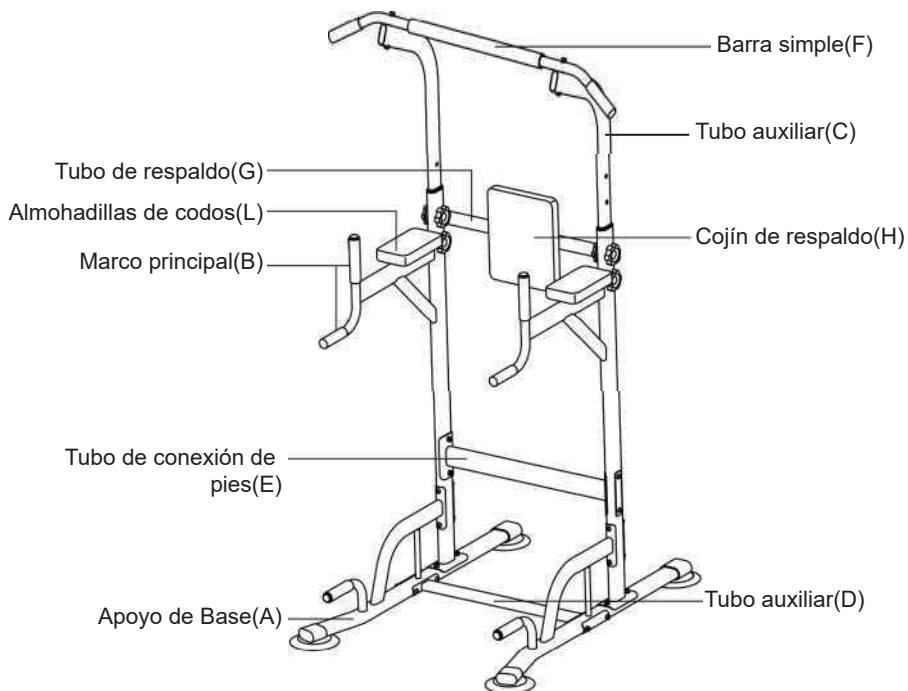









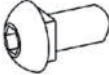





## TABLA DE IDENTIFICACIÓN DE PIEZAS

Utilice los dibujos a continuación para identificar las piezas pequeñas necesarias para el montaje. El número debajo de cada dibujo es el número clave de la pieza.







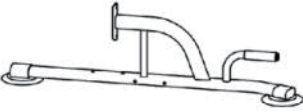

Nota: Si una pieza no está en el kit de hardware, verifique si se ha preensamblado en el producto. Es posible que se requieran piezas adicionales.

Primero haga una clasificación de los accesorios, lo cual es un paso muy importante. Coloque todas las piezas en un área despejada y colóquelas en el piso frente a usted. Quite todos los materiales de embalaje y vuelva a colocarlos en la caja. No deseche los materiales de embalaje hasta que se complete el montaje. Lea todos los pasos con atención antes de comenzar el ensamblaje.

Lista de piezas	Nombre	Imagen	Especificación	Cantidad
1	Tornillo de cuello cuadrado con cabeza redonda		M8*40	4
2	Tornillo hexagonal interior		M8*70	8
3	Tornillo hexagonal interior		M8*80	2
4	Tornillo hexagonal interior		M8*40	4
5	Tornillo hexagonal interior		M8*15	2
6	Tornillo de manija de plástico		M8*45	4
7	Tuerca de manija de plástico		M8	4
8	Tuerca de M8		M8	18
9	Placa de respaldo de arco		13*3	4
10	Placa de respaldo reforzada		13*3	2

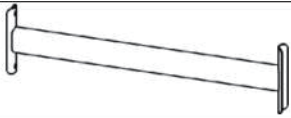
11	Arandela circular		68	6
12	Arandela de Arco		68	4
13	Herramienta de instalación hexagonal		5#	1
14	Llave		10#-13#	1

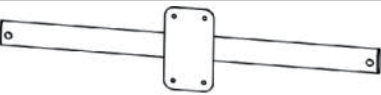
## ACCESSORIES DETAILS

	Nombre	Imagen	Cantidad
A	Apoyo de base		2
B	Marco principal		2
C	Tubo auxiliar		2
D	Tubo auxiliar		1
E	Tubo de conexión de pies		1
F	Barra simple		1
G	Tubo de respaldo		1
H	Cojín de respaldo		1
L	Almohadillas de codos		2

# ENSAMBLAJE

Después de confirmar que están todos los accesorios, comience la instalación

NOTA: POR FAVOR NO APRIETE TODOS LOS PERNOS DE FORMA SEGURA HASTA EL PASO 9.

## Paso 1

① Identificar la base izquierda y la derecha (A)

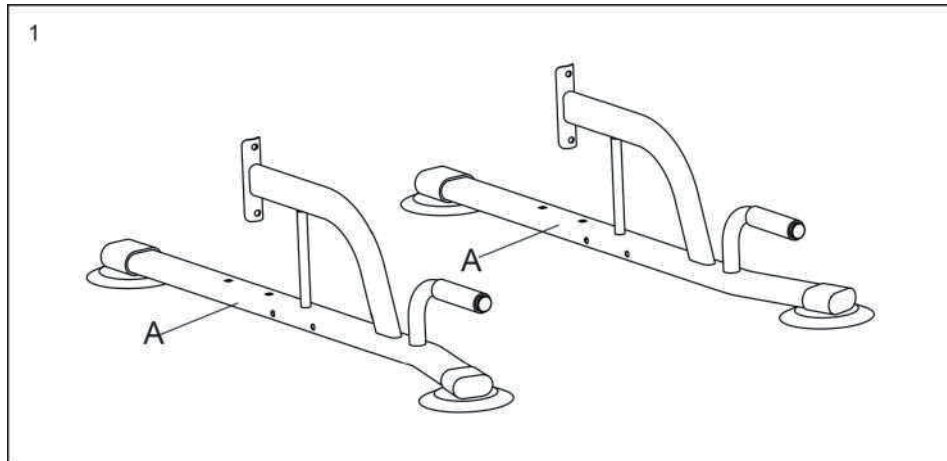

## Paso 2 Conectar la Base (A) y el Tubo de Pies (D)

① Conecte los dos tubos de pies (D) y la base (A) con los cuatro tornillos hexagonales interiores M8 \* 70 (2) y luego apriete la placa de arco (9) con las tuercas de seguridad M8 (8).

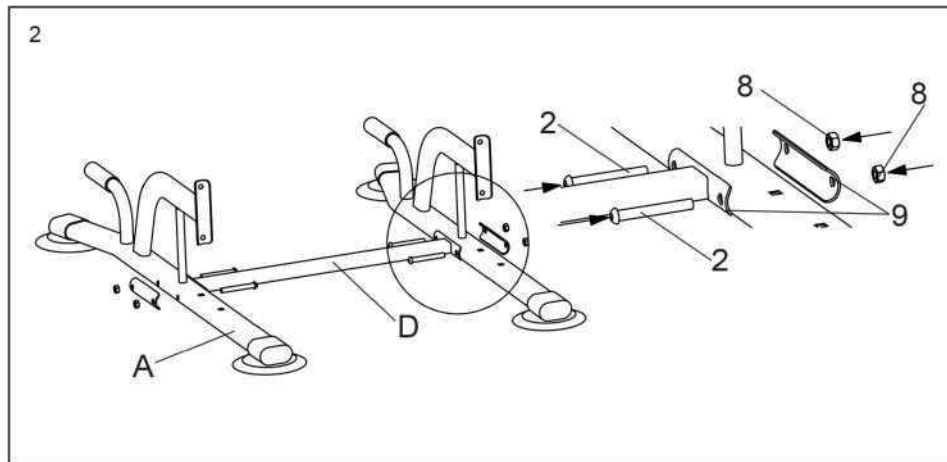

### Paso 3 Instalar el marco principal

- ① Conecte las 2 piezas del marco principal (B) con 4 tornillos de cuello cuadrado de cabeza redonda M8 \* 40 (1) desde la parte inferior a través de la base (A). Coloque la junta redonda 11, y apriete con la tuerca M8 (8).
- ② Use 4 tornillos hexagonales interiores M8 \* 70 (2) de la base (A) para conectar al marco principal y coloque la almohadilla curva (9) y apriete con la tuerca M8 (8).

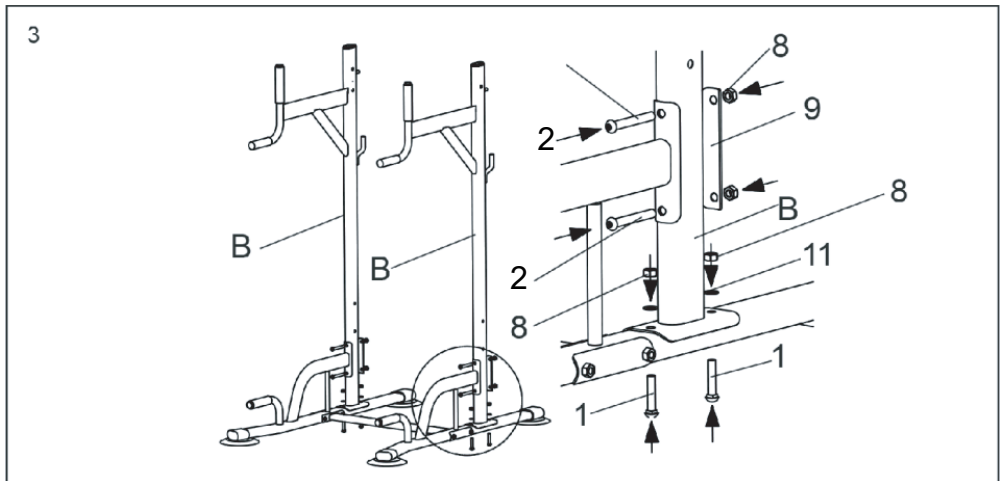

### Paso 4 Instalar el Marco Principal

- ① Fije la junta supervisora (E) con 4 tornillos hexagonales interiores M8 \* 40 (4), conecte el marco principal (B), pase la almohadilla reforzada (10) desde el exterior y apriétela con la tuerca M8 (8).

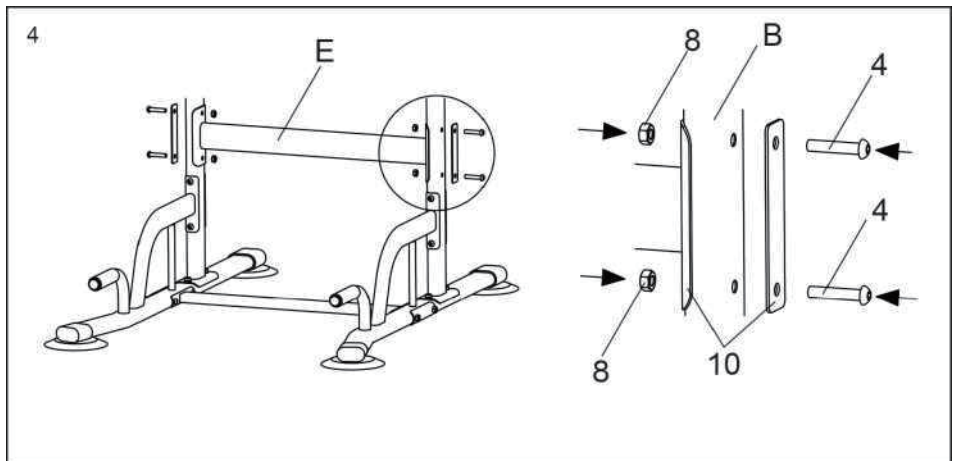

### Paso 5 Instalar la almohadilla de Codo (L)

① Sujete la placa de hierro y la almohadilla del codo (L) con el tornillo autopropulsado en el marco principal (B)

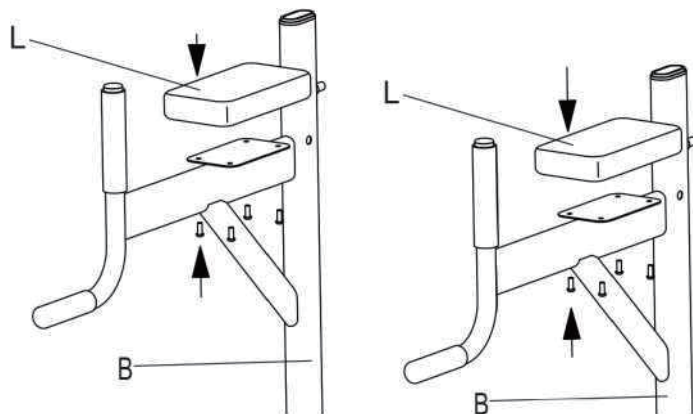

### Paso 6 Instalación de cojines (H)

① Fije la almohadilla del respaldo (H) al tubo del respaldo (G) con los tornillos del tubo del respaldo (G).

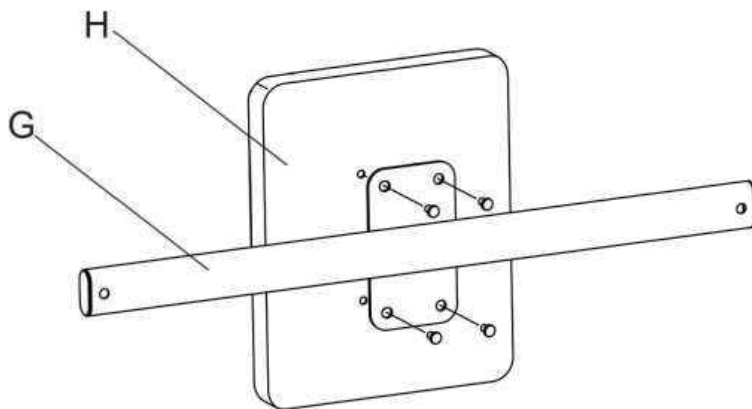

### Paso 7 Instalar el extremo posterior (C)

① Fije el tubo del respaldo (G) al marco principal (B) con el tornillo hexagonal interior M8 \* 15 (5) y luego apriete la placa redonda (11) con la llave hexagonal interior.

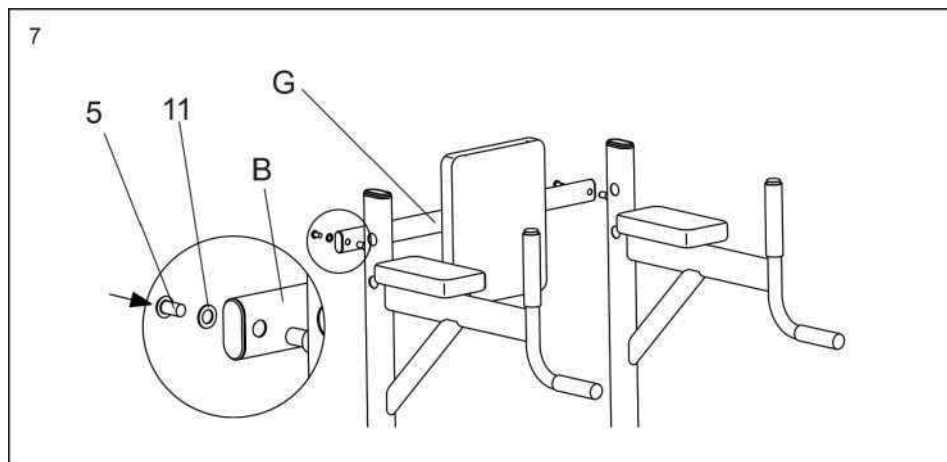

### Paso 8 Instalar la barra simple (F)

① Fije la barra simple (F) al tubo auxiliar (C) con tornillos hexagonales internos M8 \* 80 (3) y luego apriete la placa de arco (12) a ellos con contratuercas M8 (8). Nota: Alinéalos con los orificios de los tornillos

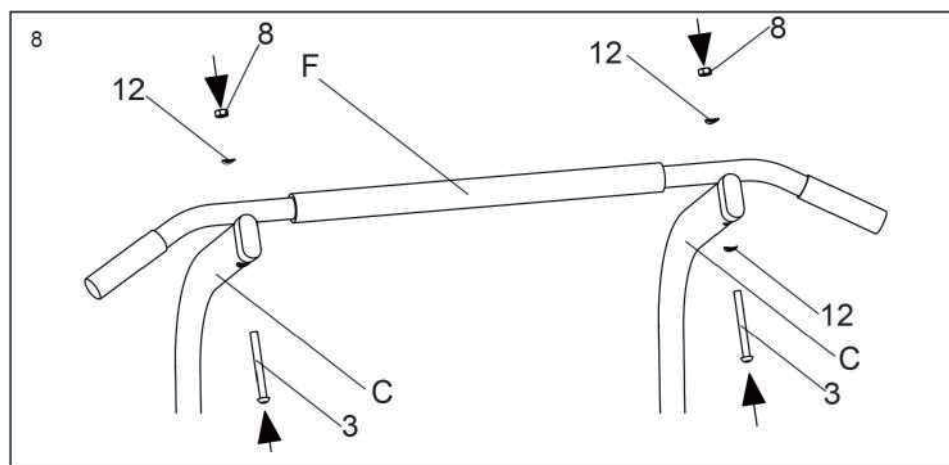

### Paso 9 Instalar el tubo auxiliar (C)

① Coloque el tubo auxiliar (c) a través de la parte superior del marco principal (B) y ajuste la altura adecuada para alinear los orificios de los tornillos, luego apriete el tornillo de manija de plástico M8 \* 45 (6) con las tuercas de manija de plástico (7).

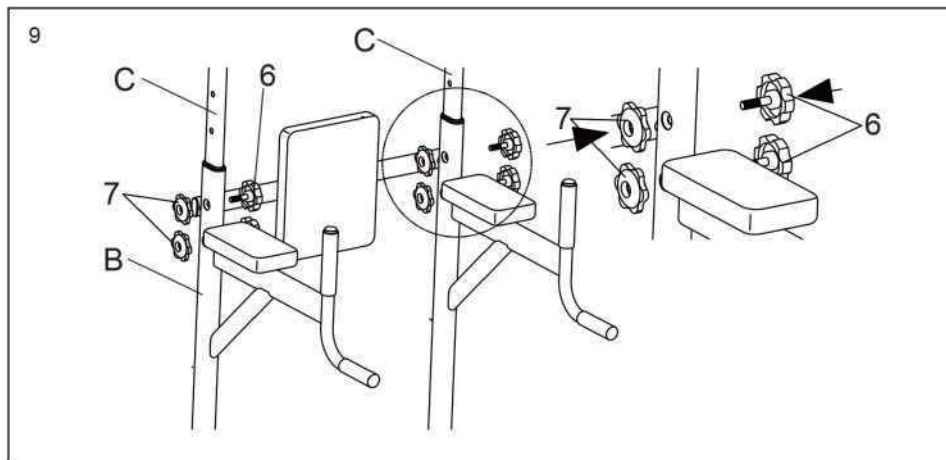

## INSTALACIÓN COMPLETADA

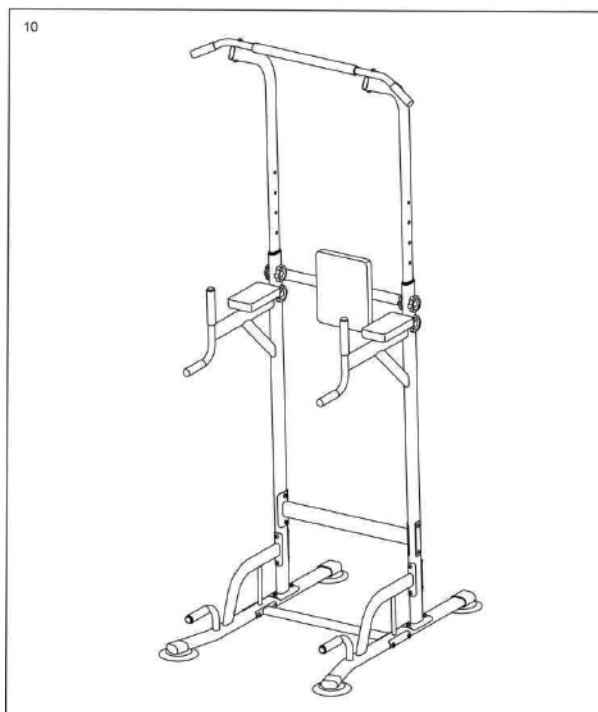

# DIBUJO DE DEPIECES

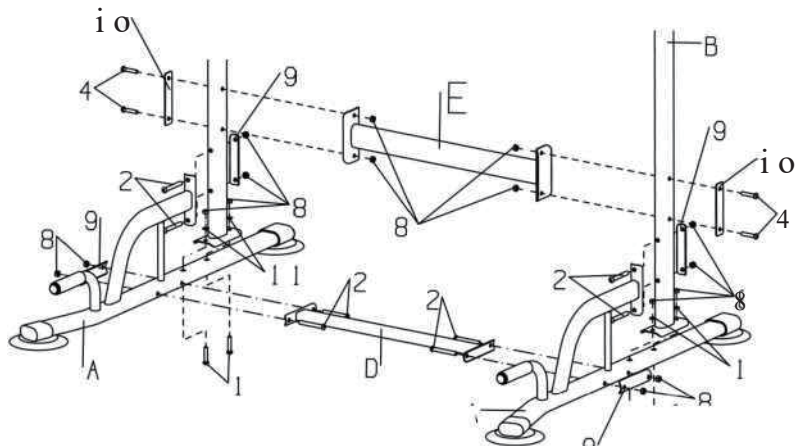
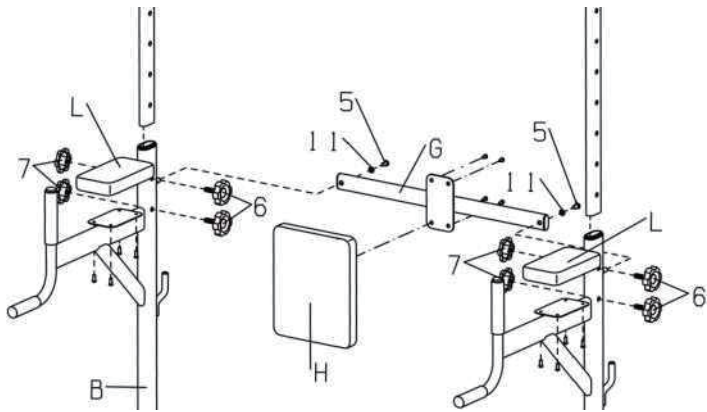
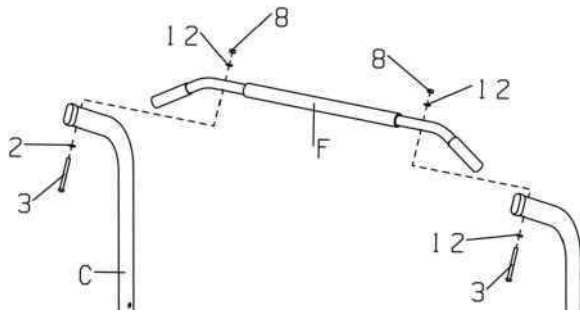

**A91-106**

**PT**

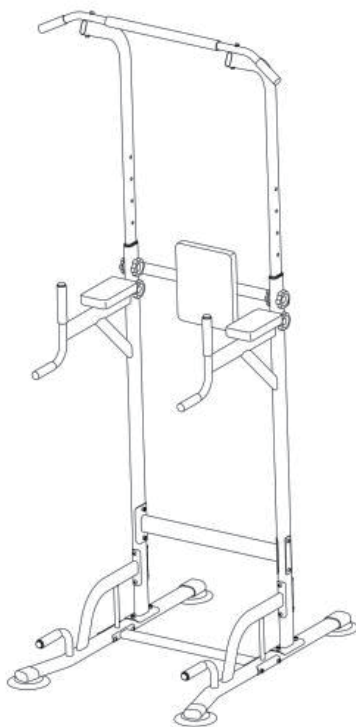

## Máquina de Pesos Ajustável

LEIA E GUARDE ESTA INSTRUÇÃO PARA REFERÊNCIA FUTURA

# MANUAL DE INSTRUÇÕES

## COLOCAÇÃO DE ETIQUETAS DE AVISOS

Este desenho mostra a(s) localização(ões) da(s) etiqueta(s) de aviso. Se alguma etiqueta estiver em falta ou ilegível, consulte a capa deste manual e solicite uma etiqueta de substituição gratuita. Anexe a etiqueta no local indicado.

Nota: Os rótulos podem não ser exibidos em tamanho real.

### ADVERTÊNCIA

Peso do utilizador: Máximo \*  
120 KG Leia todas as precauções e instruções deste manual antes de utilizar este equipamento.

O produto pode não ser capaz de realizar todos os exercícios listados.

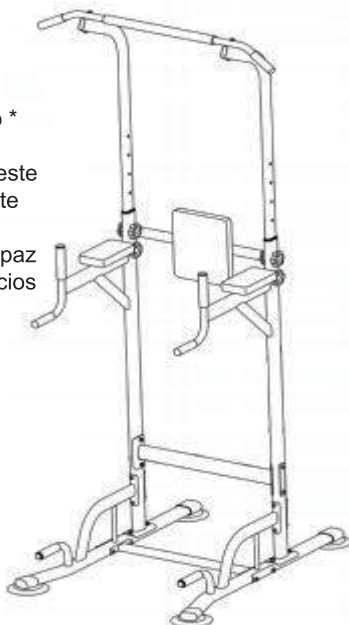

### ADVERTÊNCIA

Para evitar lesões na cabeça, manter o corpo na posição correcta..

### ADVERTÊNCIA

A má utilização desta máquina pode resultar em lesões graves.

Ler o manual do proprietário antes de usar e seguir todos os avisos e instruções.

Não permitir que crianças se aproximem ou estejam perto da máquina.

Manter o corpo, vestuário e cabelo limpos e afastados de todas as partes móveis.

Substituir o rótulo se este estiver danificado, ilegível ou caído.

## PRECAUÇÃO

Leia todas as precauções e instruções contidas neste manual antes de utilizar este equipamento. Guarde este manual para referência futura.

# PRECAUÇÕES IMPORTANTES

**ADVERTÊNCIA:** Para reduzir o risco de ferimentos graves, leia todas as precauções e instruções importantes neste manual e todos os avisos no seu equipamento de exercício antes de o utilizar. A nossa empresa não assume qualquer responsabilidade por danos pessoais ou danos materiais sofridos por ou através da utilização deste produto.

1. O proprietário deve assegurar-se de que todos os utilizadores do stand de exercício estão devidamente informados de todas as precauções.
2. Antes de iniciar qualquer programa de exercícios, consulte o seu médico para aconselhamento. Isto é especialmente importante para pessoas com mais de 35 anos de idade ou pessoas com problemas de saúde pré-existentes.
3. Utilizar o apoio ao exercício apenas como descrito neste manual.
4. O suporte de exercício destina-se apenas a uso doméstico. Não utilizar o stand de exercício num ambiente comercial, de aluguer ou institucional.
5. Manter o suporte de exercício dentro de casa, longe da humidade e do pó. Não colocar o Suporte de Exercício numa garagem ou pátio coberto, ou perto de água.
6. Utilizar o suporte de exercício apenas sobre uma superfície plana. Cobrir o chão debaixo do suporte de exercício para proteger o chão.
7. Certifique-se de que todas as peças são apertadas com segurança cada vez que utilizar o suporte de exercício. Substituir imediatamente uma peça desgastada quando esta for detectada.
8. Manter sempre as crianças com menos de 12 anos e os animais de estimação afastados da bancada de exercício.
9. O Suporte de Exercício foi concebido para suportar um peso máximo de 120 KG. 10. Use sempre sapatos atléticos para proteger os seus pés durante o exercício.

O exercício excessivo pode resultar em lesões graves ou morte. Se sentir desconforto ou dor durante o exercício, pare imediatamente e descanse.

Consulte o seu médico antes de iniciar um programa de exercícios. Isto é especialmente importante se tiver mais de 35 anos, nunca tiver exercitado antes, ou se estiver grávida ou tiver quaisquer problemas de saúde. Este produto é apenas para uso doméstico. Não utilizar em aplicações institucionais ou comerciais. A não observância de todos os avisos e instruções pode resultar em lesões corporais e danos materiais. Para reduzir o risco de ferimentos graves, leia as seguintes instruções de segurança antes de utilizar o suporte.

## ANTES DE COMEÇAR

Obrigado por seleccionar o versátil bastidor de exercícios STRENGTH TOWER.

O suporte de exercício STRENGTH TOWER foi concebido para o ajudar a desenvolver os principais grupos musculares da parte superior do corpo. Quer o seu objectivo seja uma figura informe, um tamanho e força muscular dramática, ou um sistema cardiovascular vascular mais saudável, o Bastidor de Exercício ajudá-lo-á a alcançar os resultados específicos que deseja. Para seu benefício, leia atentamente este manual antes de utilizar o Apoio ao Exercício. Se tiver alguma questão depois de ler este manual, por favor consulte a capa deste manual. Antes de continuar a ler o manual, reveja o desenho abaixo e familiarize-se com as peças indicadas.

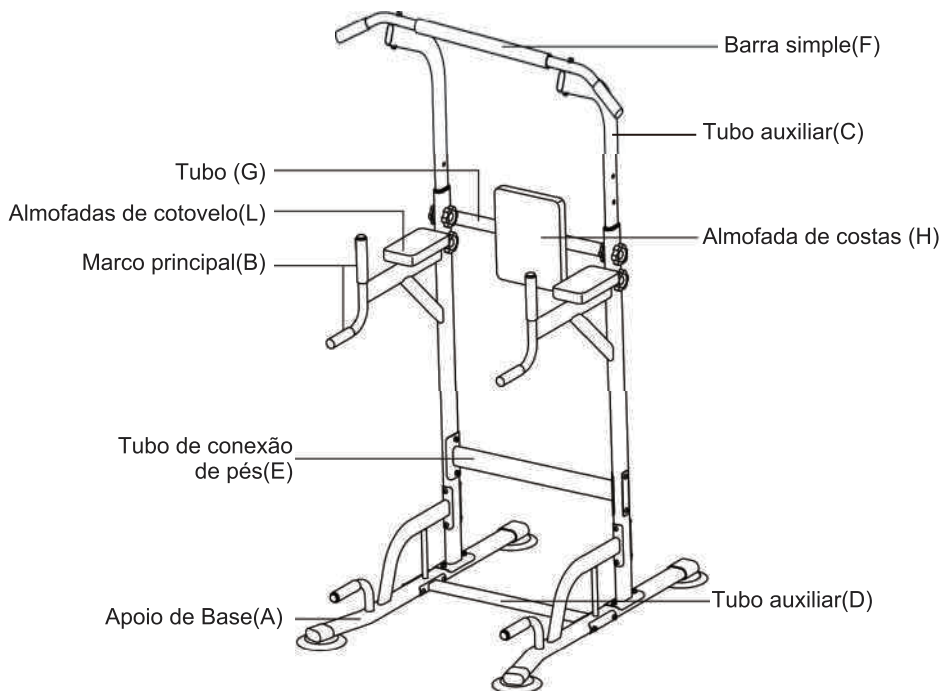









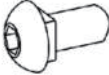





## TABELA DE IDENTIFICAÇÃO DE PEÇAS

Utilize os desenhos abaixo para identificar as pequenas peças necessárias para a montagem. O número abaixo de cada desenho é o número da peça chave.







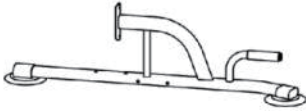

Nota: Se uma peça não estiver no kit de hardware, verificar se foi pré-montada no produto. Poderão ser necessárias peças adicionais.

Ordenar primeiro através dos acessórios, o que é um passo muito importante. Coloque todas as peças numa área livre e coloque-as no chão à sua frente. Retirar todos os materiais de embalagem e colocá-los de volta na caixa. Não descartar materiais de embalagem até que a montagem esteja completa. Leia cuidadosamente todos os passos antes de iniciar a montagem.

Lista de peças	Nome	Imagem	Especificação	Quantidade
1	Parafuso do pescoço quadrado com cabeça redonda		M8*40	4
2	Parafuso hexagonal interior		M8*70	8
3	Parafuso hexagonal interior		M8*80	2
4	Parafuso hexagonal interior		M8*40	4
5	Parafuso hexagonal interior		M8*15	2
6	Parafuso de manivela de plástico		M8*45	4
7	Parafuso de pegada de plástico		M8	4
8	Porca de M8		M8	18
9	Placa de suporte em arco		13*3	4
10	Placa de suporte reforçada		13*3	2

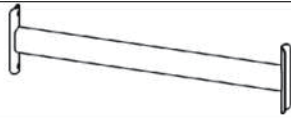
11	Anilha Circular		68	6
12	Anilha de Arco		68	4
13	Ferramenta de instalação hexagonal		5#	1
14	Chave		10#-13#	1

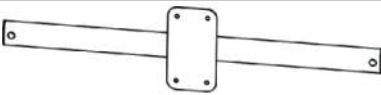
## DETALHES DOS ACESSÓRIOS

	Nome	Imagem	Quantidade
A	Apoio de base		2
B	Marco principal		2
C	Tubo auxiliar		2
D	Tubo auxiliar		1
E	Tubode conexão de pés		1
F	Barra simples		1
G	Tubode suporte		1
H	Almofada de encosto		1
L	Almofadas de cotovelos		2

# MONTAGEM

Depois de confirmar que todos os acessórios estão presentes, iniciar a instalação.

NOTA: POR FAVOR NÃO APERTAR TODOS OS PARAFUSOS COM SEGURANÇA ATÉ AO PASSO 9.

Passo 1 • Identificar a base esquerda e direita (A).

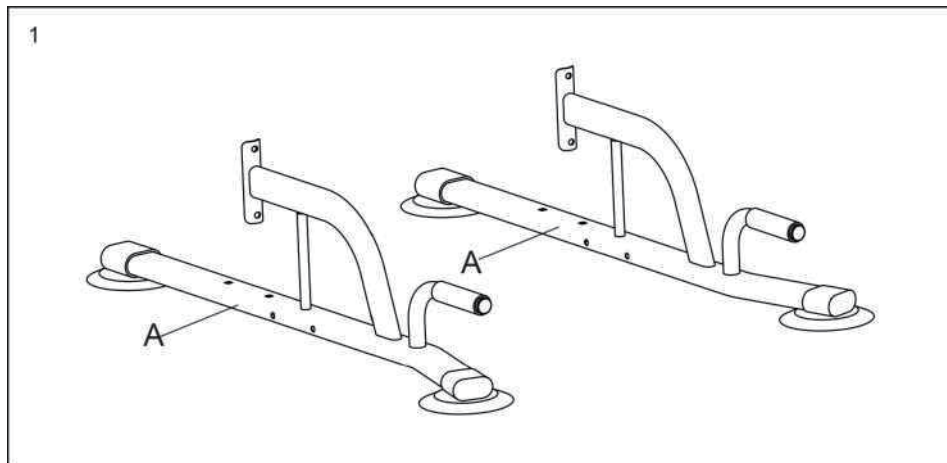

Passo 2 Ligar Base (A) e Tubo de Pé (D).

• Ligar os dois tubos de pé (D) e a base (A) com os quatro parafusos hexagonais internos M8 \* 70 (2) e depois apertar a placa de proa (9) com as porcas de segurança M8 (8).

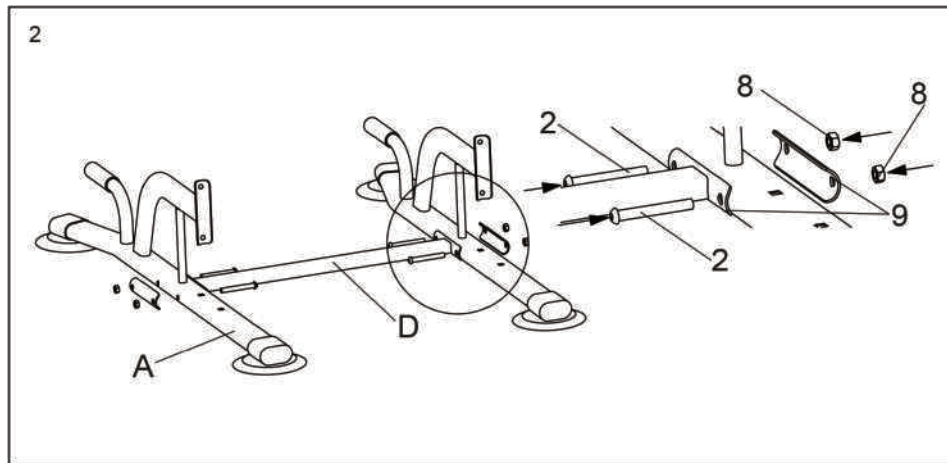

### Passo 3 Instalar a estrutura principal

- Ligar as 2 peças da estrutura principal (B) com 4 M8 \* 40 parafusos de pescoço quadrado de cabeça redonda (1) a partir do fundo através da base (A). Encaixar a junta redonda 11, e apertar com a porca M8 (8).
- Use 4 M8 \* 70 parafusos hexagonais internos (2) da base (A) para ligar à estrutura principal e encaixar a almofada curva (9), e apertar com a porca M8 (8).

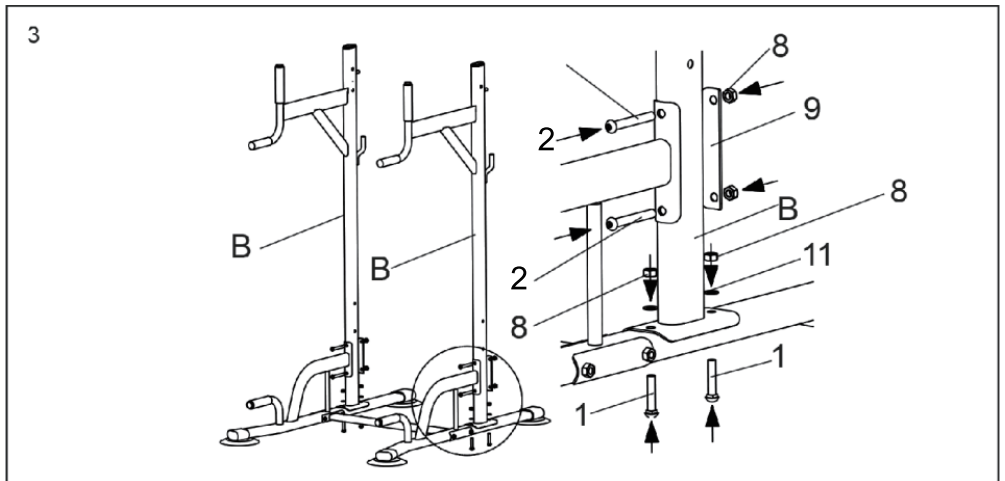

### Passo 4 Instalar o quadro principal

- Fixar a junta do supervisor (E) com 4 parafusos sextavados interiores M8 \* 40 (4), ligar a estrutura principal (B), passar a almofada reforçada (10) do exterior e apertar com a porca M8 (8).

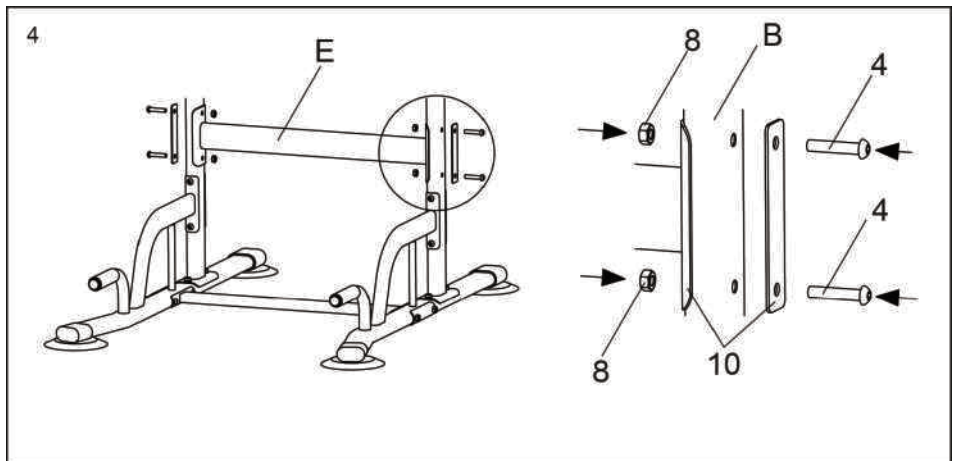

Passo 5 Instalar o Cotovelo (L).

- Fixar a placa de ferro e o cotovelo (L) com o parafuso auto-roscante na armação principal (B).

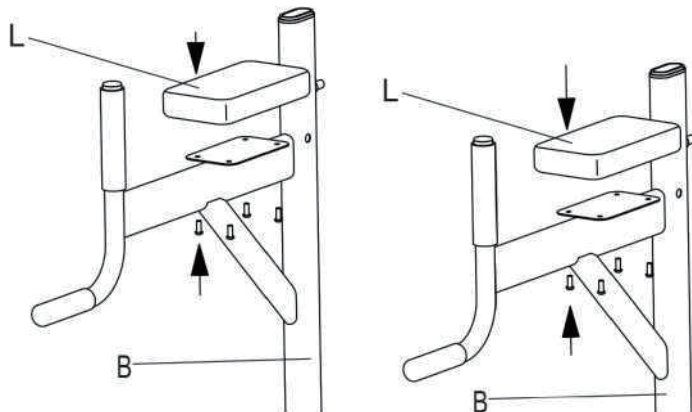

Passo 6 Instalação de almofadas (H)

- Fasten a almofada de encosto (H) ao tubo de encosto (G) com os parafusos do tubo de encosto (G).

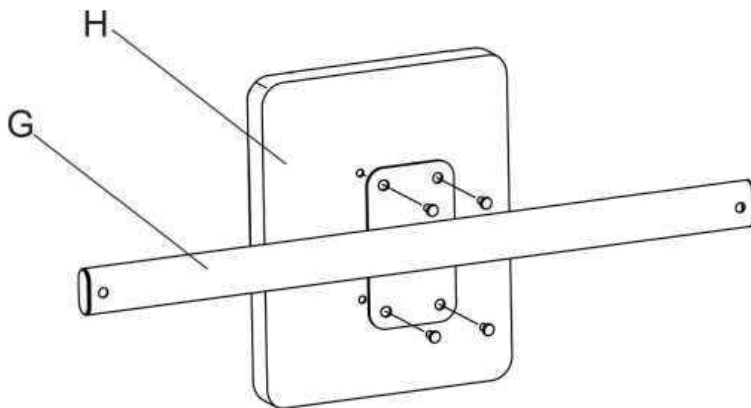

Passo 7 Instale a extremidade traseira (C).

- Fixar o tubo da extremidade traseira (G) à estrutura principal (B) com o parafuso de tampa da cabeça da tomada M8 \* 15 (5) e depois apertar a placa redonda (11) com a chave da cabeça da tomada.

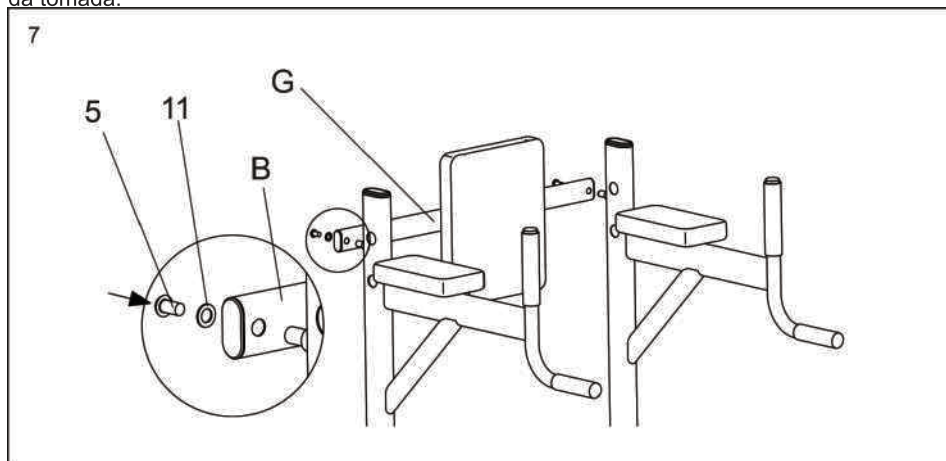

Passo 8 Instalar barra única (F)

- Fixar a barra simples (F) ao tubo auxiliar (C) com parafusos hexagonais internos M8 \* 80 (3) e depois apertar-lhes a placa do arco (12) com porcas de segurança M8 (8). Nota: Alinhe-os com os orifícios dos parafusos.

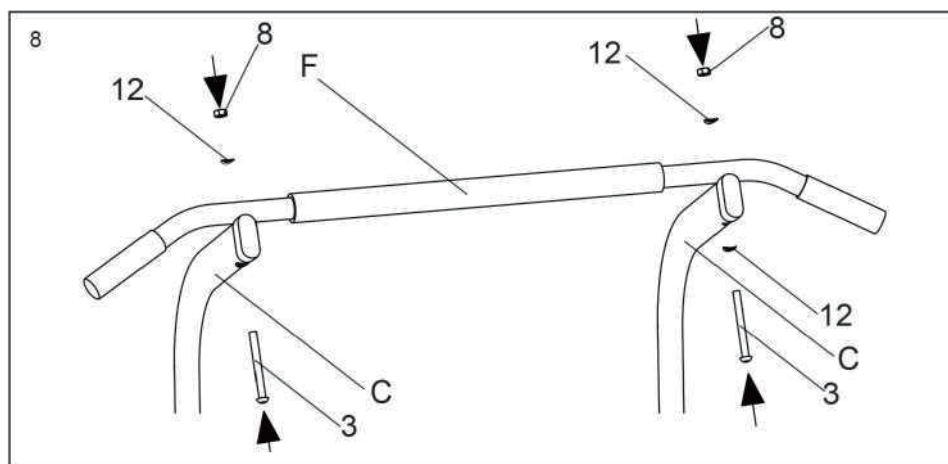

### Paso 9 Instalar el tubo auxiliar (C)

- Coloque el tubo auxiliar (c) a través de la parte superior del marco principal (B) y ajuste la altura adecuada para alinear los orificios de los tornillos, luego apriete el tornillo de manija de plástico M8 \* 45 (6) con las tuercas de manija de plástico (7).

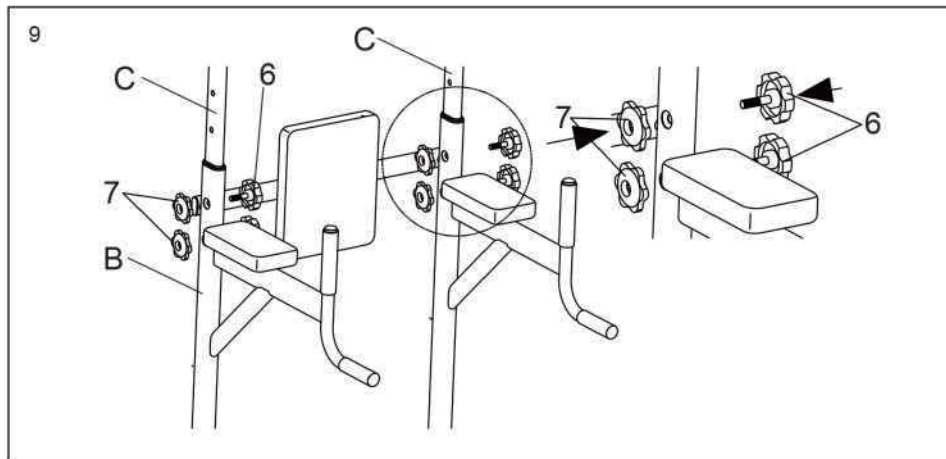

## INSTALAÇÃO CONCLUÍDA

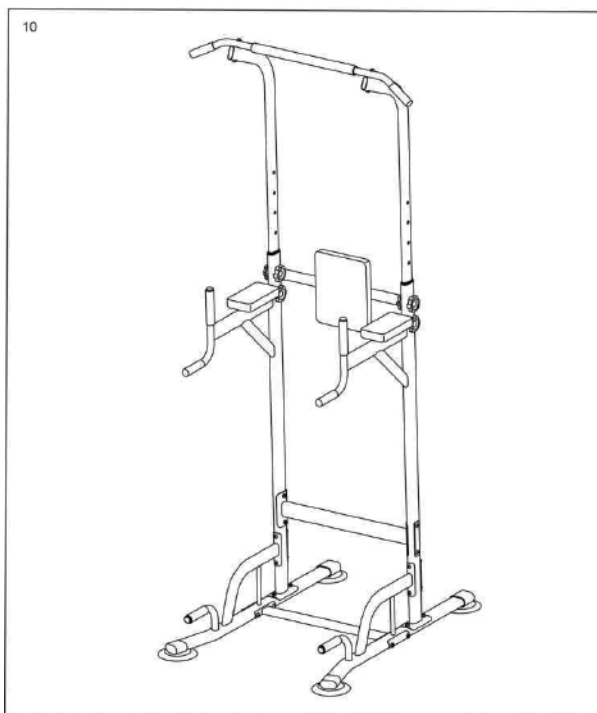

# ILUSTRAÇÃO DAS PEÇAS

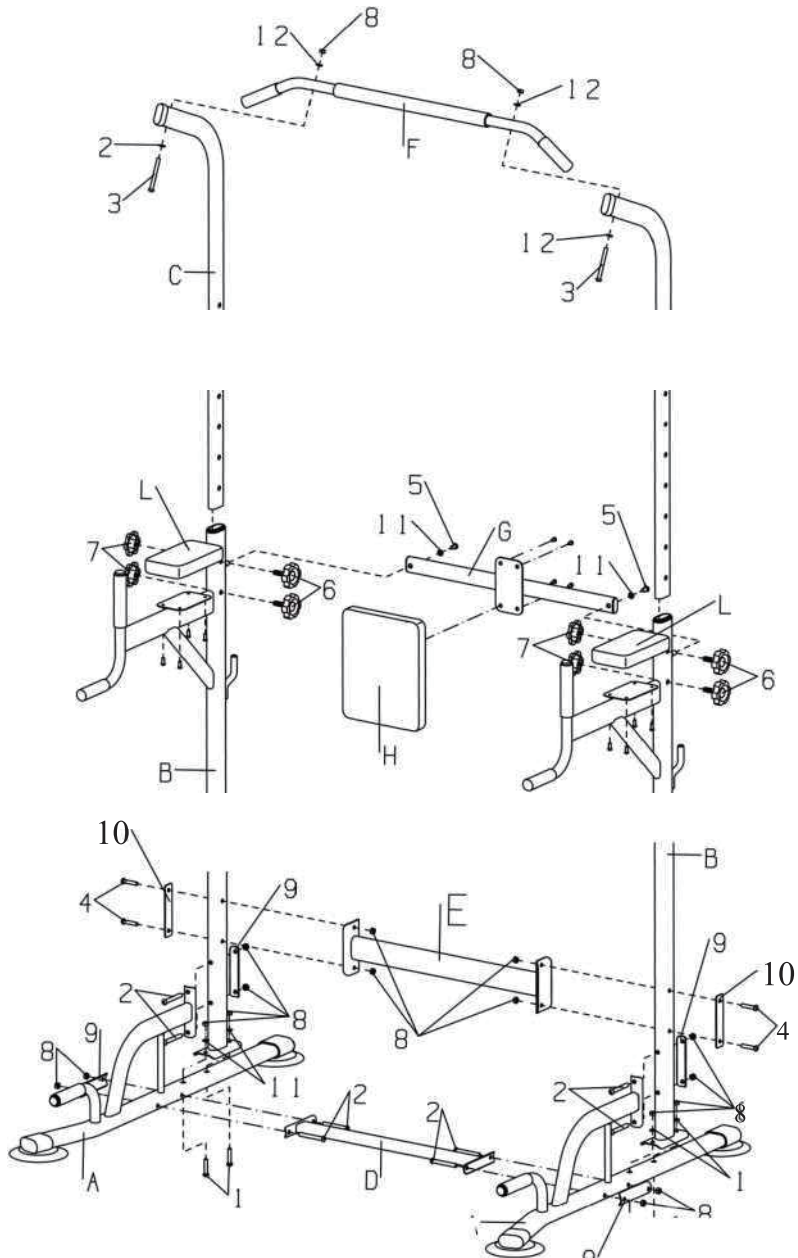

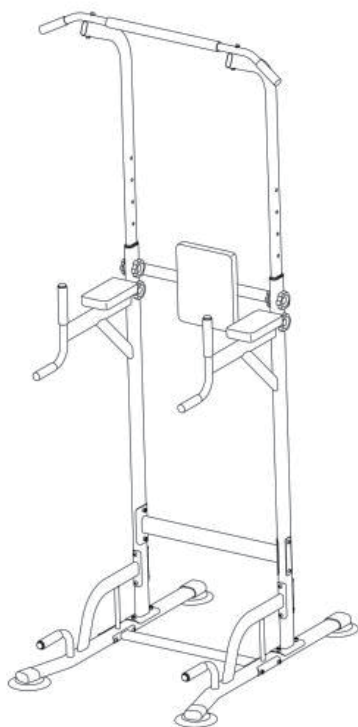

## Stazione stabilizzata per esercizi

IMPORTANTE - CONSERVARE QUESTE INFORMAZIONI  
PER CONSULTARLE IN SEGUITO: LEGGERE ATTENTAMENTE

**ISTRUZIONI DI ASSEMBLAGGIO**

## AVVERTENZE SUL POSIZIONAMENTO

Questo disegno mostra la posizione o le posizioni dell'avviso. Se un'etichetta è mancante o illeggibile, consultare la copertina di questo manuale e richiedere un'etichetta sostitutiva gratuita. Applicare l'etichetta nella posizione indicata. Nota: le etichette potrebbero non essere visualizzate con le dimensioni effettive

### AVVERTIMENTO

PESO: MAX 120 KG

Leggere tutte le precauzioni e le istruzioni in questo manuale prima di utilizzare questa apparecchiatura

- Il prodotto potrebbe non offrire tutti gli esercizi elencati

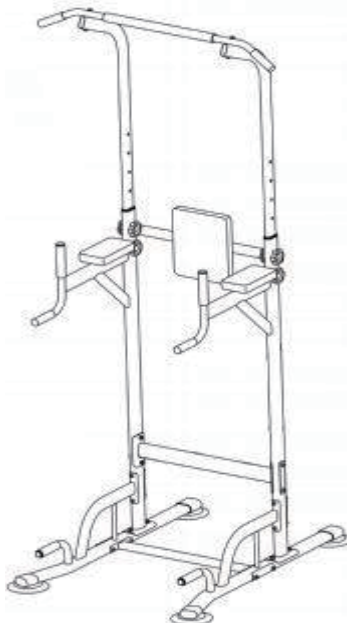

### AVVERTIMENTO

Distanza libera dall'alto.

Per prevenire lesioni alla testa posizionare correttamente il corpo.

### • AVVERTIMENTO

- L'uso improprio di questa macchina può provocare gravi lesioni

- Leggere il manuale dell'utente prima dell'uso e seguire tutte le avvertenze e istruzioni.

- Non lasciare che i bambini usino o sia nelle vicinanze del macchinario

- • Mantenere il corpo, i vestiti e i capelli liberi da tutte le parti in movimento.

- • Sostituire l'etichetta se danneggiata, illeggibile o rimossa.

### ATTENZIONE

Leggere tutte le precauzioni e le istruzioni contenute in questo manuale prima di utilizzare questa apparecchiatura. Conservare questo manuale per riferimenti futuri.

**AVVERTENZA:** Per ridurre il rischio di lesioni gravi, leggere tutte le precauzioni e le istruzioni importanti contenute in questo manuale e tutte le avvertenze prima di utilizzare il macchinario. Non si assume alcuna responsabilità per lesioni personali o danni alla proprietà subiti da o attraverso l'uso di questo prodotto.

1. È responsabilità del proprietario assicurarsi che tutti gli utenti della stazione siano adeguatamente informati di tutte le precauzioni.
2. Prima di iniziare qualsiasi programma di allenamento, consultare il proprio medico. Ciò è particolarmente importante per le persone di età superiore ai 35 anni o per persone con problemi di salute preesistenti.
3. Utilizzare la stazione solo come descritto nel presente manuale.
4. La stazione per esercizi è destinata esclusivamente all'uso domestico. Non utilizzare la palestra in un ambiente commerciale, a noleggio o istituzionale.
5. Mantenere la palestra in ambienti chiusi, lontano da umidità e polvere. Non posizionare la stazione in un garage o in un patio coperto o vicino all'acqua
6. Utilizzare la stazione solo su una superficie piana. Coprire il pavimento sotto la stazione per proteggere il pavimento.
7. Accertarsi che tutte le parti siano strette correttamente ogni volta che si utilizza la stazione per esercizi. Sostituire immediatamente tutte le parti usurate.
8. Tenere sempre i bambini di età inferiore ai 12 anni e gli animali domestici lontano dalla stazione per esercizi.
9. Il prodotto è progettato per supportare un peso massimo dell'utente di 120 kg
10. Indossare sempre scarpe da ginnastica per proteggere i piedi durante l'allenamento
11. Un allenamento eccessivo può provocare lesioni gravi o mortali. Se vi sentite svenire o avvertite dolore durante l'allenamento, fermatevi immediatamente e rinfrescatevi.

**Consultare il proprio medico prima di iniziare questo o qualsiasi programma di allenamento. Ciò è particolarmente importante se avete più di 35 anni, non vi siete mai esercitati prima, siete incinta o soffrite di problemi di salute. Questo prodotto è solo per uso domestico. Non utilizzare in applicazioni istituzionali o commerciali. La mancata osservanza di tutte le avvertenze e istruzioni può provocare lesioni personali e danni materiali. Per ridurre il rischio di lesioni gravi, leggere le seguenti istruzioni di sicurezza prima di utilizzare la stazione per esercizi.**

## PRIMA DI INIZIA

Grazie per aver scelto la versatile stazione per esercizi POWER TOWER. La stazione per esercizi POWER TOWER è progettata per aiutarvi a sviluppare i principali gruppi muscolari della parte superiore del corpo. Sia che il vostro obiettivo sia una figura formosa, una dimensione e una forza dei muscoli migliori o un sistema cardiovascolare più sano, la stazione per esercizi vi aiuterà

Per vostra conoscenza, leggete attentamente questo manuale prima di utilizzare la stazione per esercizi. In caso di domande dopo aver letto questo manuale, consultare la copertina di questo manuale.

Prima di leggere altro, si prega di rivedere il disegno sottostante e familiarizzare con le parti che sono etichettate.

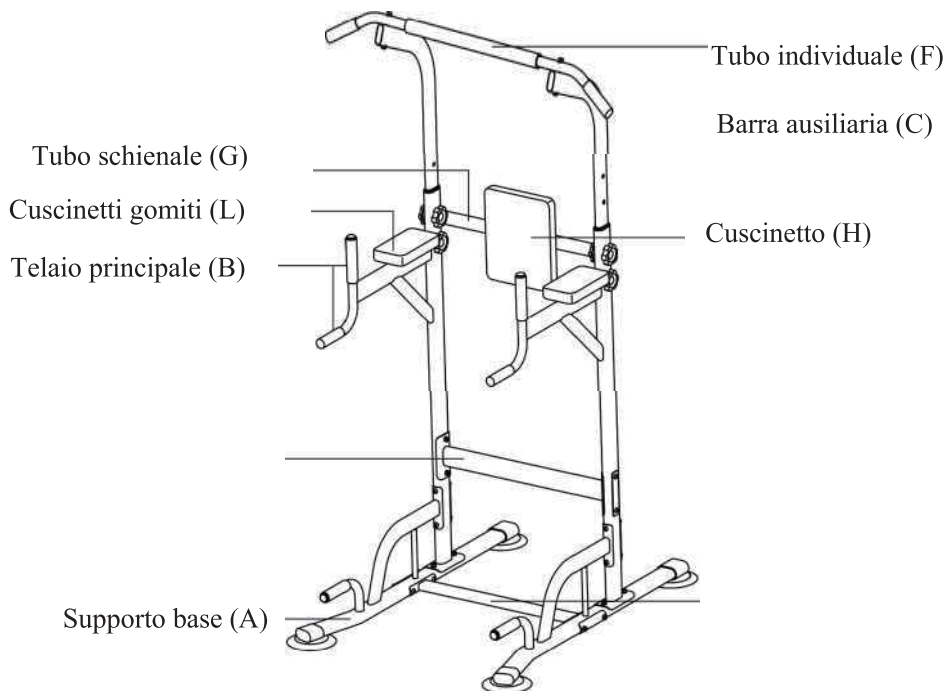















## DIAGRAMMA IDENTIFICAZIONE PARTI

Utilizzare i disegni seguenti per identificare le piccole parti necessarie per il montaggio. Il numero tra parentesi sotto ogni disegno è il numero chiave della parte.





**Nota: se una parte non è presente nel kit hardware, verificare se è stata pre-assemblata. Parti extra possono essere incluse.**



**Si prega di fare prima una classificazione degli accessori, il che è molto importante! Posizionare tutte le parti dalla scatola in un'area libera e posizionarle sul pavimento di fronte a voi. Rimuovere tutti i materiali di imballaggio dalla propria area e rimetterli nella scatola. Non gettare i materiali di imballaggio fino al completamento del montaggio. Leggere attentamente ogni passaggio prima di iniziare.**

Lista Parti	Nome	Illustrazione	Specifiche	Quantita'
1	Vite quadrata a testa tonda		M8*40	4
2	Vite esagonale interna		M8*70	8
3	Vite esagonale interna		M8*80	2
4	Vite esagonale interna		M8*40	4
5	Vite esagonale interna		M8*15	2
6	Vite con impugnatura in plastica		M8*45	4
7	Dado con impugnatura in plastica		M8	4
8	Dado M8		M8	18

Lista Parti	Nome	Illustrazione	Specifiche	Quantita'
9	Placca di supporto ad arco		13*3	4
10	Placca di supporto ad arco rinforzata		13*3	2
11	Guarnizione circolare		Φ8	6
12	Guarnizione ricurva		Φ8	4
13	Chiave a brugola		5#	1
14	Chiave		10#-13#	1

### DETTAGLI DEGLI ACCESSORI

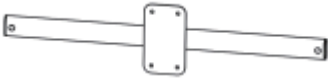
Lista Parti	Nome	Illustrazione	Specifiche
A	Supporto base		2
B	Telaio principale		2
C	Barra ausiliaria		2
D	Barra ausiliaria		1
	Tubo connessione piedi		1

Lista Parti	Nome	Illustrazione	Specifiche
F	Barra individuale		1
G	Barra schienale		1
H	Cuscinetto		1
L	Cuscinetti gomiti		2

## ASSEMBLAGGIO

Dopo aver verificato l'integrità di tutti gli accessori, avviare l'installazione

**NOTA: NON STRINGERE TROPPO TUTTI I BULLONI FINO AL PASSAGGIO 9.**

### Step 1

- ① Identifica la base sinistra e destra (A)

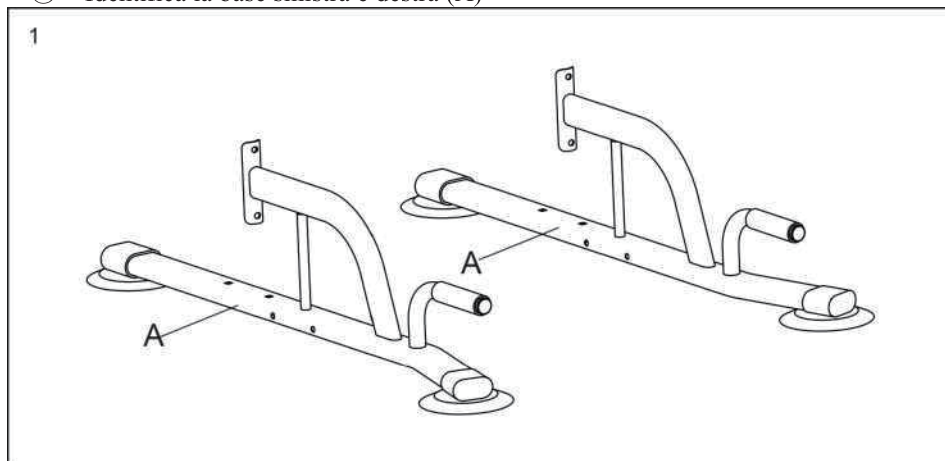

## Passaggio 2 Collegare la base (A) e il tubo di base (D)

1. Collegare i due tubi di fondo (D) e la base (A) con le quattro viti esagonali interne M8 \* 70 (2), quindi stringere ad esse la piastra ad arco (9) con i controdadi M8 (8).

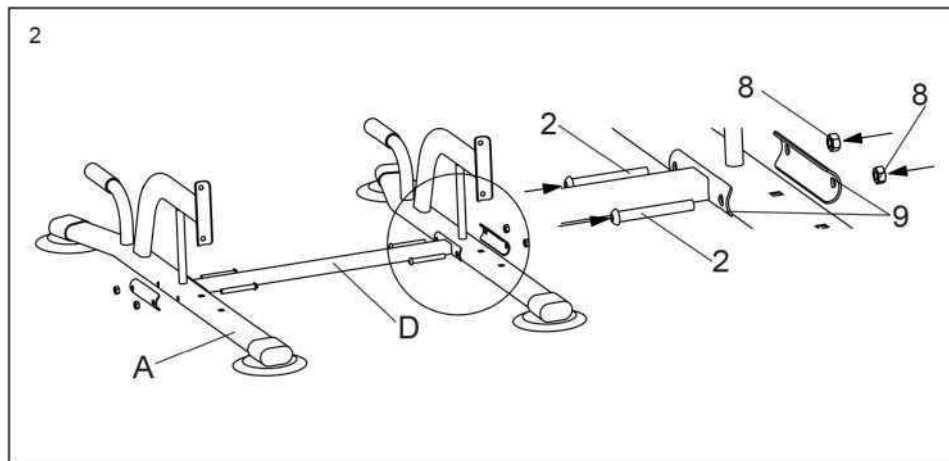

## Passaggio 3 Installare il telaio principale

1. Trovare il telaio principale (B), 2 pezzi con 4 viti a testa tonda M8 \* 40 a testa tonda (1), installare dal basso attraverso la base (A), inserire la guarnizione circolare 11, stringere con il dado M8 (8)
2. Utilizzare 4 viti esagonali interne M8 \* 70 (2) dalla base (A) per collegarsi al telaio principale e mettere il cuscinetto curvo (9) e stringere con il dado M8 (8)

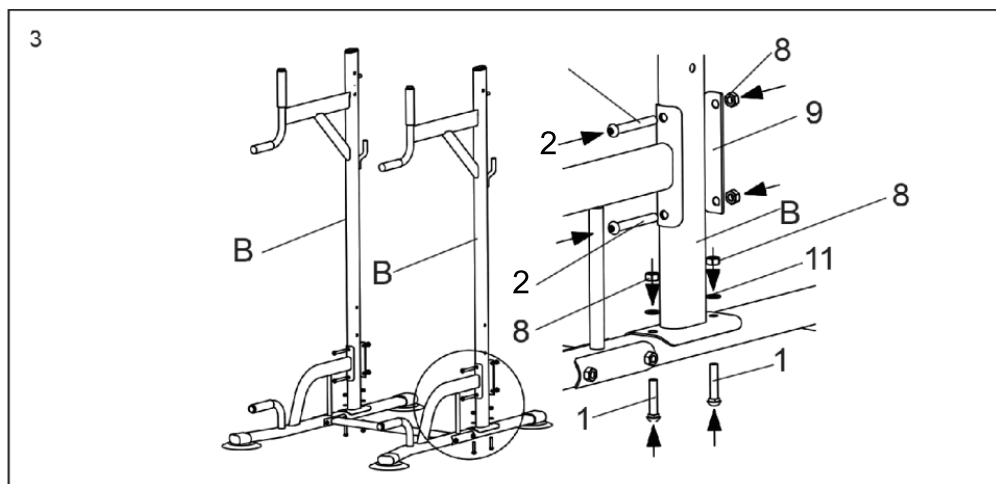

## Passaggio 4 Installare il telaio principale

- ① Trovare il giunto del connettore (E) con 4 viti esagonali interne M8 \* 40 (4), collegare con il telaio principale (B) far passare il cuscinetto di rinforzo (10) dall'esterno e stringere con il dado M8 (8).

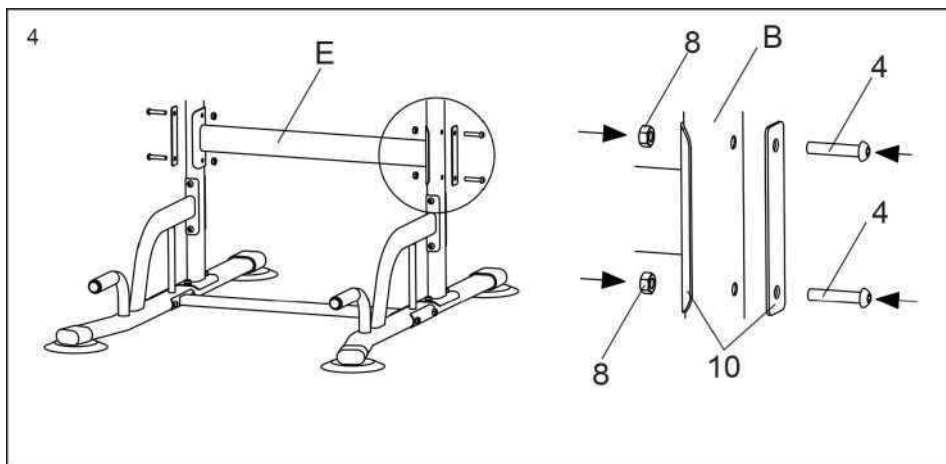

## Passaggio 5 Installare i cuscinetti per il gomito (L)

- ① Fissare attraverso la piastra di ferro e il gomito (L) con la vite semovente sul telaio principale (B)

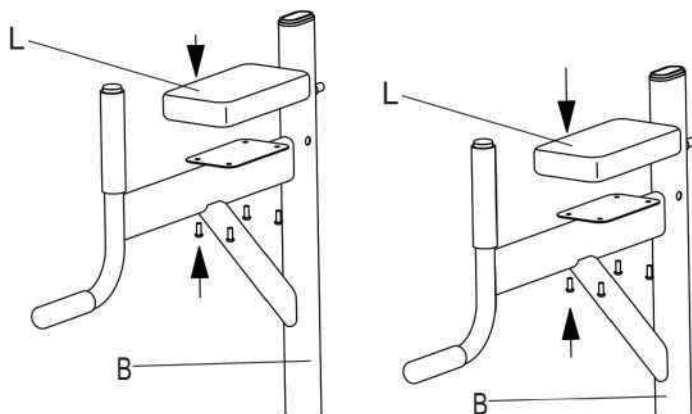

## Passaggio 6 Installare il cuscinetto (H)

- ① Collegare il cuscinetto dello schienale (H) al tubo dello schienale (G) con le viti del tubo dello schienale (G).

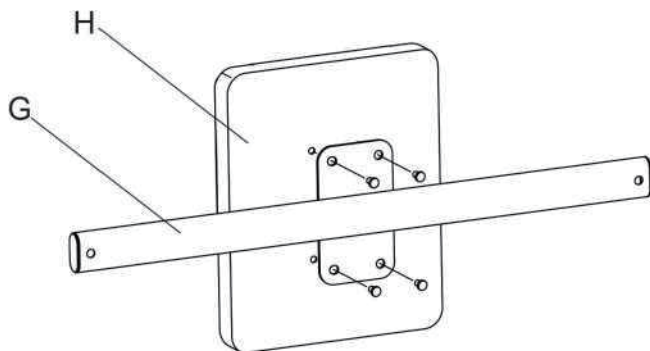

## Passaggio 7 Installare lo schienale (G)

- ① Fissare il tubo dello schienale (G) al telaio principale (B) con la vite esagonale interna M8 \* 15 (5), quindi stringere ad essi la piastra rotonda (11) con la chiave esagonale interna

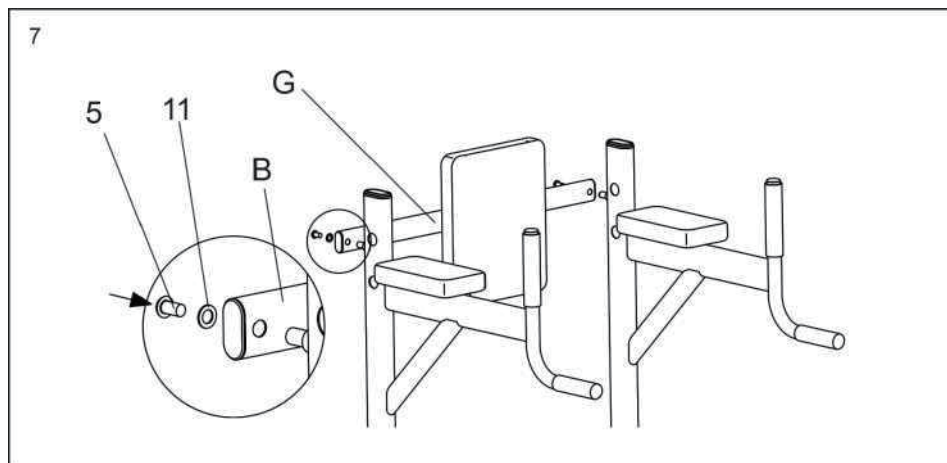

## Passaggio 8 Installare la barra individuale (F)

- ① Collegare la barra individuale (F) al tubo ausiliario (C) con le viti esagonali interne M8 \* 80 (3), quindi stringere ad esse la piastra dell'arco (12) con i controdadi M8 (8). Nota: orientare i fori delle viti

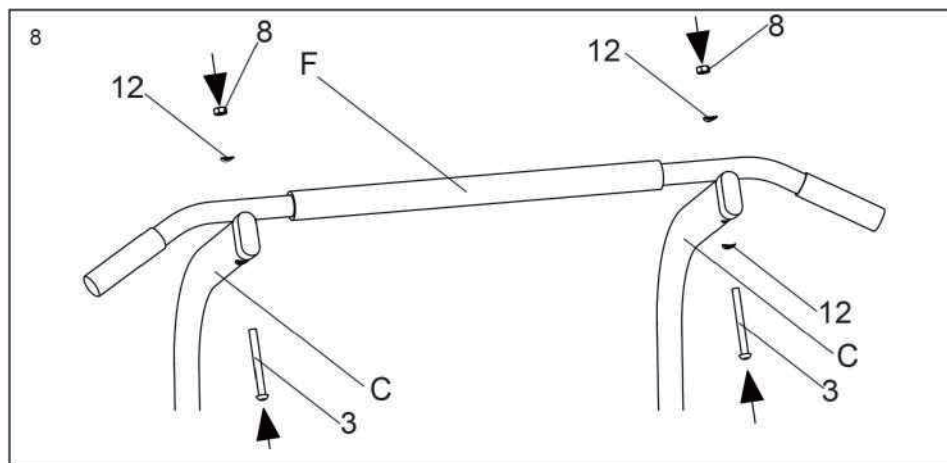

## Passaggio 9 installare il tubo ausiliario (C)

- ① Inserire il tubo ausiliario (C) attraverso la parte superiore del telaio principale (B) e regolare l'altezza corretta per orientare i fori delle viti, quindi serrare a loro le viti dell'impugnatura in plastica M8 \* 45 (6) con i dadi dell'impugnatura in plastica (7).

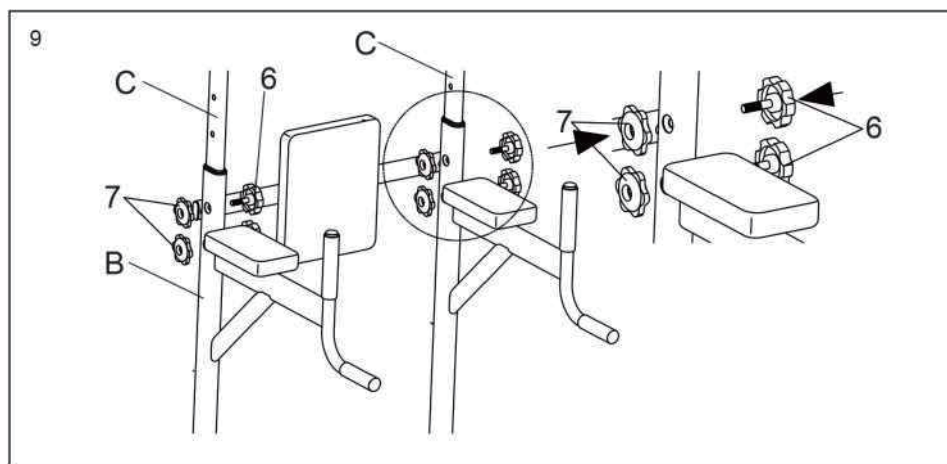

## INSTALLAZIONE COMPLETA

10

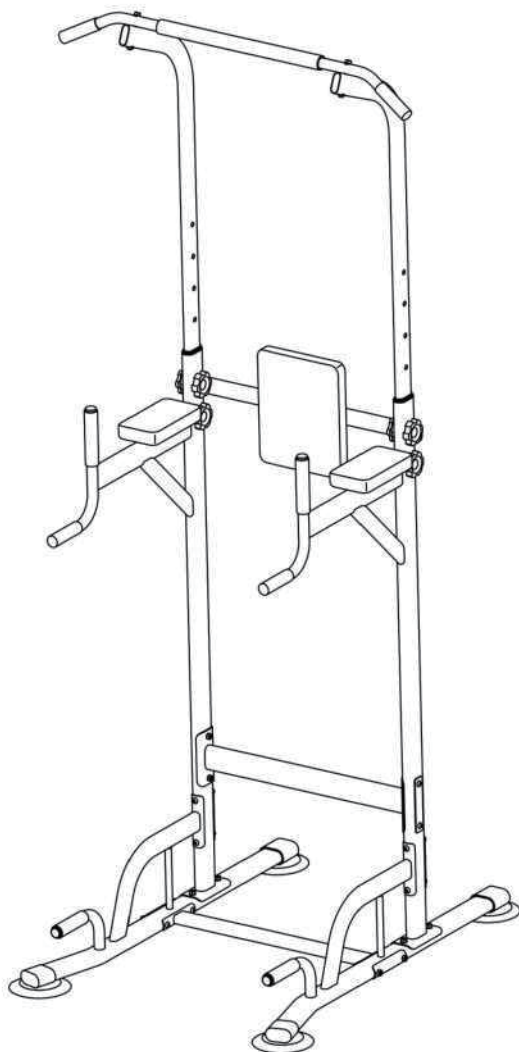

# VISTA ESPLOSA

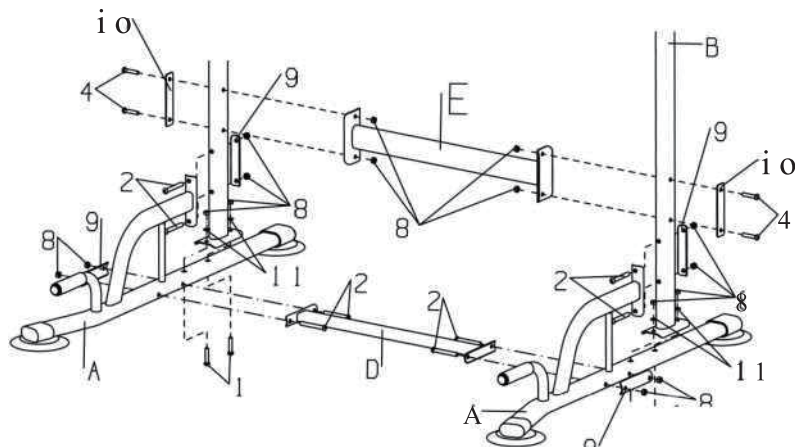
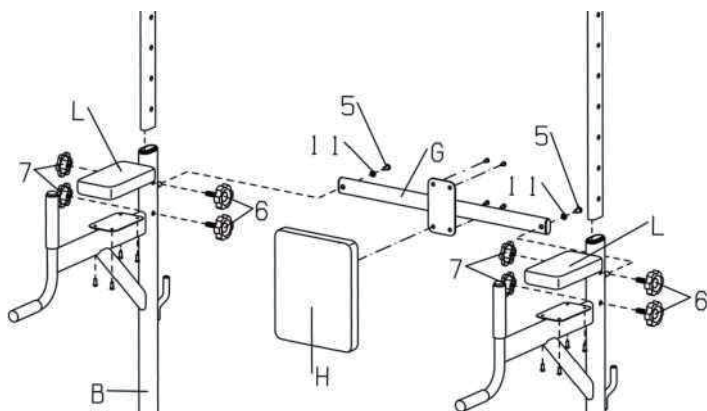
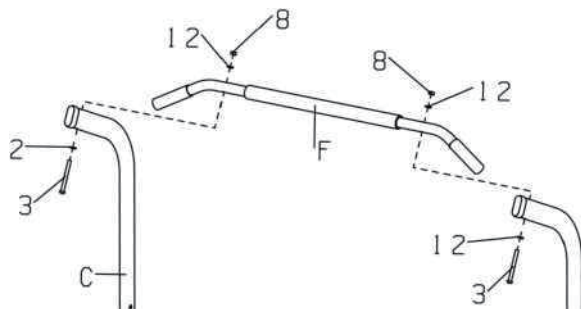

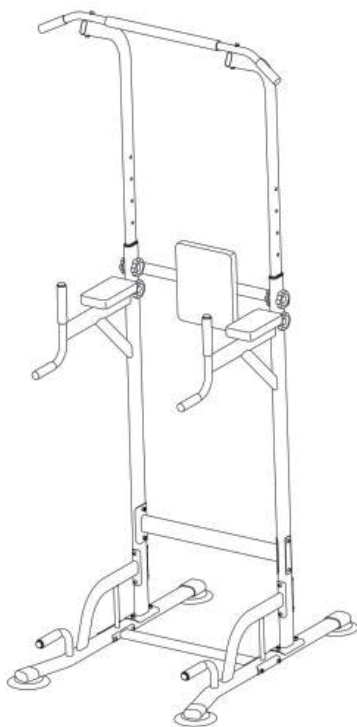

## Einstellbarer Kraftturm für schwere Arbeiten

LESEN UND BEWAHREN SIE DIESE ANLEITUNG FÜR SPÄTERE REFERENZ AUF.

# MONTAGEANLEITUNG

## ANBRINGEN DER WARNHINWEISE

Diese Zeichnung zeigt die Position(en) der Warneaufkleber. Wenn ein Aufkleber fehlt oder unleserlich ist, sehen Sie bitte auf dem Deckblatt dieses Handbuchs nach und fordern Sie einen kostenlosen Ersatzaufkleber an. Bringen Sie den Aufkleber an der abgebildeten Stelle an. Hinweis: Die Etiketten werden möglicherweise nicht in ihrer tatsächlichen Größe angezeigt.

### WARNUNG

Benutzergewicht: max. \* 120 kg  
Lesen Sie alle  
Vorsichtsmaßnahmen und  
Anweisungen in diesem  
Handbuch, bevor Sie dieses  
Gerät verwenden.  
Es ist möglich, dass Sie nicht  
alle aufgeführten Übungen mit  
dem Produkt durchführen  
können.

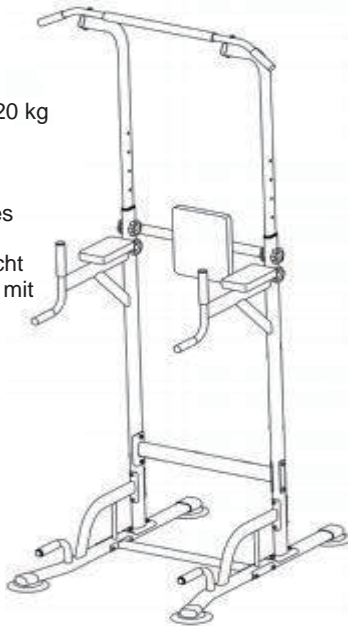

### WARNUNG

Um Kopfverletzungen zu vermeiden, halten Sie Ihren Körper in der richtigen Position.

### WARNUNG

Die unsachgemäße Verwendung dieses Geräts kann zu schweren Verletzungen führen.

Lesen Sie vor der Verwendung die Bedienungsanleitung und befolgen Sie alle Warnhinweise und Anweisungen.

Lassen Sie Kinder nicht in die Nähe der Maschine kommen oder sich in ihrer Nähe aufhalten.

Halten Sie Ihren Körper, Ihre Kleidung und Ihre Haare frei und fern von allen beweglichen Teilen. Ersetzen Sie das Etikett, wenn es beschädigt, unleserlich oder abgefallen ist.

## VORSICHT

Lesen Sie alle Vorsichtsmaßnahmen und Anweisungen in diesem Handbuch, bevor Sie dieses Gerät verwenden. Bewahren Sie dieses Handbuch zum späteren Nachschlagen auf.

## WICHTIGE VORSICHTSMASSNAHMEN

**WARNUNG:** Um das Risiko schwerer Verletzungen zu verringern, lesen Sie vor der Verwendung alle wichtigen Vorsichtsmaßnahmen und Anweisungen in diesem Handbuch sowie alle Warnhinweise auf Ihrem Trainingsgerät. Unser Unternehmen übernimmt keine Haftung für Personen- oder Sachschäden, die durch oder durch die Verwendung dieses Produkts entstehen.

1. Der Eigentümer hat dafür Sorge zu tragen, dass alle Nutzer der Übungshilfe angemessen über alle Vorsichtsmaßnahmen informiert sind.
2. Bevor Sie mit einem Trainingsprogramm beginnen, konsultieren Sie Ihren Arzt nach Vorschlägen. Dies ist besonders wichtig für Menschen über 35 Jahre oder Menschen mit Vorerkrankungen.
3. Verwenden Sie die Übungshilfe nur wie in diesem Handbuch beschrieben.
4. Der Übungsständer ist nur für den Heimgebrauch bestimmt. Verwenden Sie die Übungsunterstützung nicht in einem kommerziellen, gemieteten oder institutionellen Umfeld.
5. Bewahren Sie den Übungsständer in geschlossenen Räumen auf, fern von Feuchtigkeit und Staub. Stellen Sie den Übungsständer nicht in einer überdachten Garage oder Terrasse oder in der Nähe von Wasser auf.
6. Verwenden Sie den Übungsständer nur auf einer ebenen Fläche. Decken Sie den Boden unter dem Übungsständer ab, um den Boden zu schützen.
7. Stellen Sie sicher, dass alle Teile bei jeder Verwendung des Übungsständers fest angezogen sind. Tauschen Sie das verschlissene Teil sofort aus, wenn Sie es entdecken.
8. Halten Sie Kinder unter 12 Jahren und Haustiere jederzeit von der Trainingsunterstützung fern.
9. Der Übungsständer ist für ein maximales Benutzergewicht von 120 kg ausgelegt.
10. Tragen Sie immer Sportschuhe, um Ihre Füße beim Training zu schützen.
11. Übermäßige Bewegung kann zu schweren Verletzungen oder zum Tod führen. Wenn Sie sich beim Training schlecht oder wund fühlen, hören Sie sofort auf und ruhen Sie sich aus. Konsultieren Sie Ihren Arzt, bevor Sie mit einem Trainingsprogramm beginnen. Dies ist besonders wichtig, wenn Sie über 35 Jahre alt sind, noch nie Sport getrieben haben, schwanger sind oder gesundheitliche Probleme haben. Dieses Produkt ist nur für den Hausgebrauch bestimmt. Nicht in institutionellen oder kommerziellen Anwendungen verwenden. Die Nichtbeachtung aller Warnungen und Anweisungen kann zu Körperverletzungen und Sachschäden führen. Um das Risiko von  
Bei schweren Verletzungen lesen Sie bitte die folgenden Sicherheitshinweise, bevor Sie den Ständer verwenden.

## BEVOR SIE BEGINNEN

Vielen Dank, dass Sie sich für die vielseitige Übungshilfe STRENGTH TOWER entschieden haben.





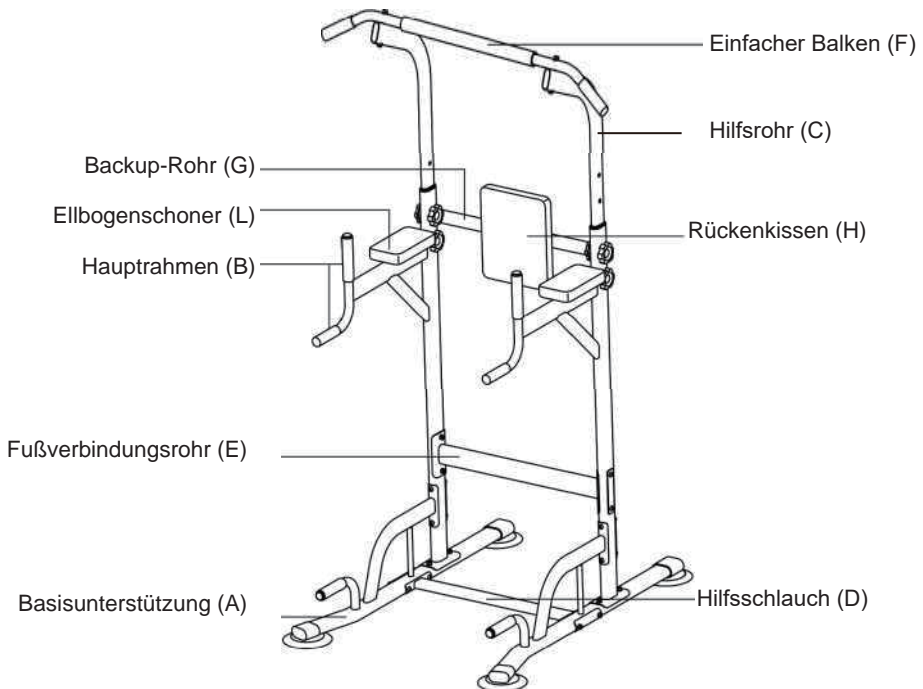



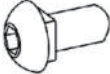

Die Übungsbandage STRENGTH TOWER wurde entwickelt, um Ihnen zu helfen, die wichtigsten Muskelgruppen in Ihrem Oberkörper zu entwickeln. Ganz gleich, ob Sie eine wohlgeformte Figur, eine dramatische Muskelgröße und -stärke oder ein gesünderes Herz-Kreislauf-System anstreben, die Trainingsunterstützung wird Ihnen helfen, die gewünschten Ergebnisse zu erzielen.





Bitte lesen Sie zu Ihrem Vorteil diese Anleitung sorgfältig durch, bevor Sie die Übungshilfe verwenden. Wenn Sie nach dem Lesen dieses Handbuchs Zweifel haben, lesen Sie bitte das Cover dieses Handbuchs. Bevor Sie das Handbuch weiter lesen, lesen Sie bitte die untenstehende Zeichnung und machen Sie sich mit den angegebenen Teilen vertraut.









## TEILIDENTIFIKATIONSTABELLE

Verwenden Sie die folgenden Zeichnungen, um die für die Montage benötigten Kleinteile zu identifizieren. Die Zahl unter jeder Zeichnung ist die Schlüsselnummer des Teils.  
 Hinweis: Wenn ein Teil nicht im Hardware-Kit enthalten ist, überprüfen Sie, ob es in das Produkt vormontiert wurde. Möglicherweise sind zusätzliche Teile erforderlich.  
 Führen Sie zunächst eine Sortierung des Zubehörs durch, was ein sehr wichtiger Schritt ist. Lege alle Teile an einen freien Ort und lege sie vor dir auf den Boden. Entfernen Sie sämtliches Verpackungsmaterial und legen Sie es wieder in den Karton. Entsorgen Sie Verpackungsmaterialien erst, wenn die Montage abgeschlossen ist. Lesen Sie alle Schritte sorgfältig durch, bevor Sie mit der Montage beginnen.

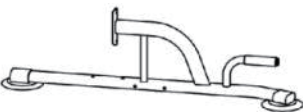
Gelistete Stücke	Name	Bild	Spezifikation	Menge
1	Vierhalbschraube mit Rundkopf		M8*40	4
2	Sechseckiger Innenbereich von Tornillo		M8*70	8
3	Sechseckiger Innenbereich von Tornillo		M8*80	2
4	Sechseckiger Innenbereich von Tornillo		M8*40	4
5	Sechseckiger Innenbereich von Tornillo		M8*15	2
6	Griffschraube aus Kunststoff		M8*45	4
7	Kunststoff-Griffmutter		M8	4
8	M8 Mutter		M8	18
9	Bogenstützplatte		13*3	4
10	Verstärkte Rückwand		13*3	2

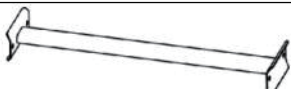
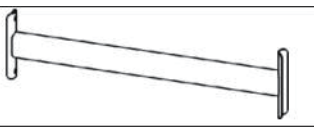
11	Rundscheibe		68	6
12	Bogen-Wandleuchte		68	4
13	Sechskant-Montagewerkzeug		5#	1
14	Schlüssel		10#-13#	1

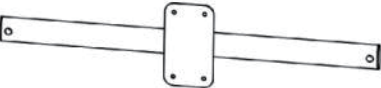
## ZUBEHÖR DETAILS

	Anzahl	Das Bild	Menge
A	Basisunterstützung		2
B	Hauptrahmen		2
C	Hilfsschlauch		2
D	Hilfsschlauch		1
E	Fußverbindungsrohr		1
F	Einfache Stange		1
G	Reserveschlauch		1
H	Rückenkissen		1
L	Ellbogenpolster		2

# ZUSAMMENBAU

Nachdem Sie sich vergewissert haben, dass alle Zubehörteile vorhanden sind, beginnen Sie mit der Installation

**HINWEIS: BITTE ZIEHEN SIE NICHT ALLE SCHRAUBEN BIS SCHRITT 9 FEST AN.**

Schritt 1

(1) Identifizieren Sie die linke und rechte Basis (A)

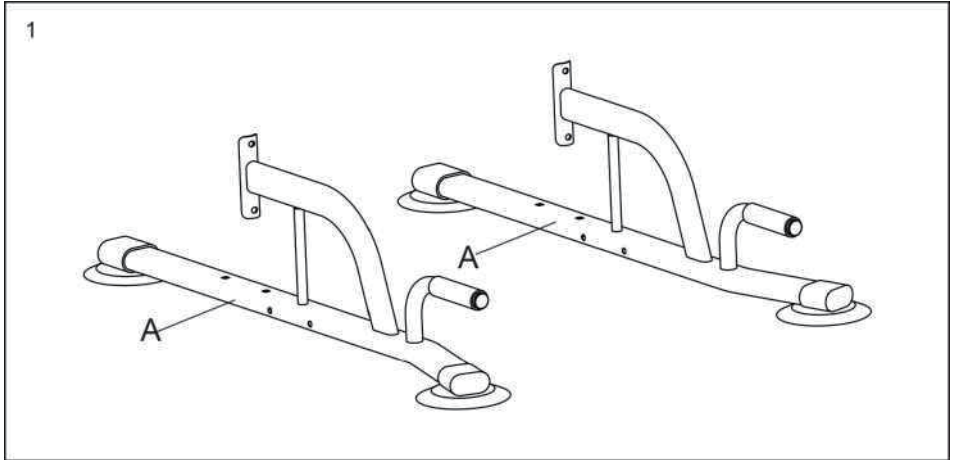

Schritt 2 Sockel (A) und Fußrohr (D) verbinden

(1) Verbinden Sie die beiden Fußrohre (D) und den Sockel (A) mit den vier inneren Sechskantschrauben M8\*70 (2) und ziehen Sie dann die Lichtbogenplatte (9) mit den M8-Kontermuttern (8) fest.

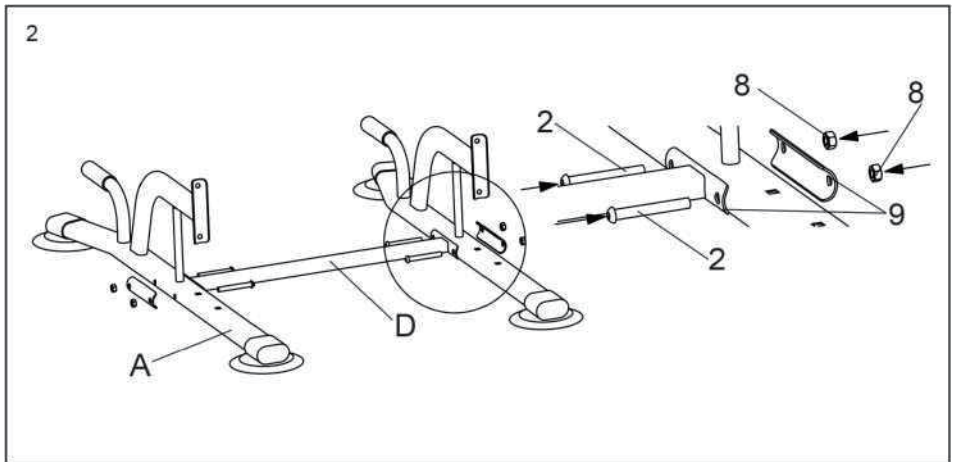

### Schritt 3: Installieren Sie den Hauptrahmen

(1) Verbinden Sie die 2 Teile des Hauptrahmens (B) mit 4 Rundkopfschrauben M8 \* 40 (1) von unten durch die Basis (A). Befestigen Sie das Rundgelenk 11 und ziehen Sie es mit der M8-Mutter (8) fest.

(2) Verwenden Sie 4 innere Sechskantschrauben M8\*70(2) von der Basis (A), um sie mit dem Hauptrahmen zu verbinden, setzen Sie das gebogene Pad (9) ein und ziehen Sie es mit der M8-Mutter (8) fest.

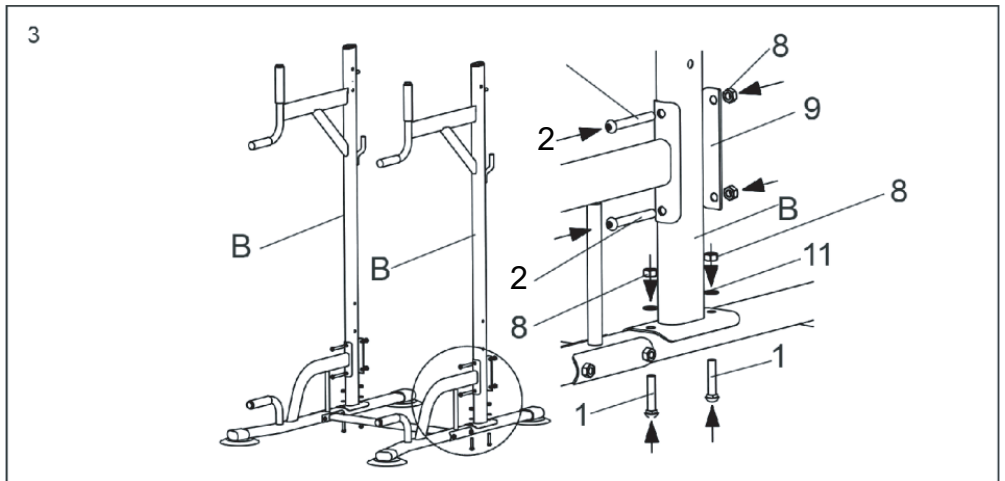

### Schritt 4 Hauptrahmen installieren

① Befestigen Sie die Überwachungsdichtung (E) mit 4 Innensechskantschrauben M8 \* 40 (4), verbinden Sie den Hauptrahmen (B), führen Sie die Verstärkungsplatte (10) von außen ein und ziehen Sie sie mit der Mutter M8 (8) fest.

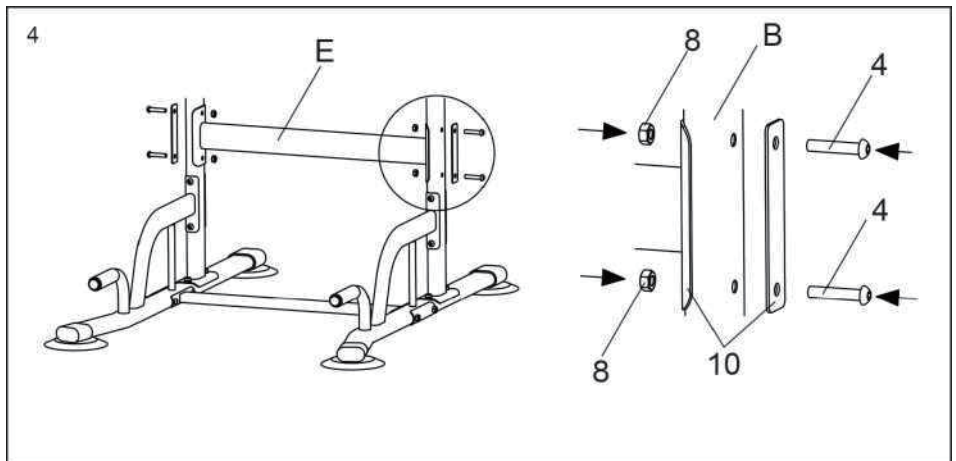

### Schritt 5: Ellbogenpolster (L) anbringen

① Befestigen Sie die Eisenplatte und das Ellbogenpolster (L) mit der selbstschneidenden Schraube am Haupttrahmen (B).

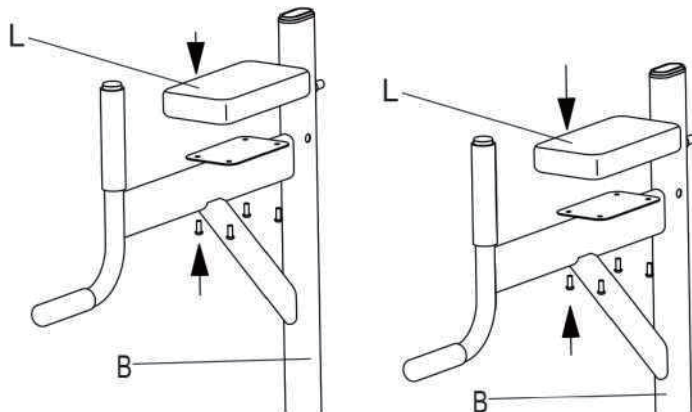

### Schritt 6 Einbau der Polster (H)

① Befestigen Sie das Rückenpolster (H) mit den Schrauben des Rückenrohrs (G) am Rückenrohr (G).

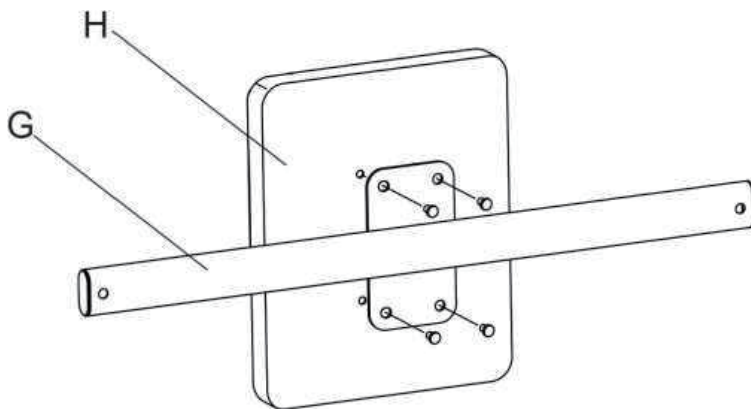

### Schritt 7 Hinteres Ende (C) montieren

① Befestigen Sie das Rückenrohr (G) mit der Innensechskantschraube M8 \* 15 (5) am Hauptrahmen (B) und ziehen Sie dann die runde Platte (11) mit dem Innensechskantschlüssel fest.

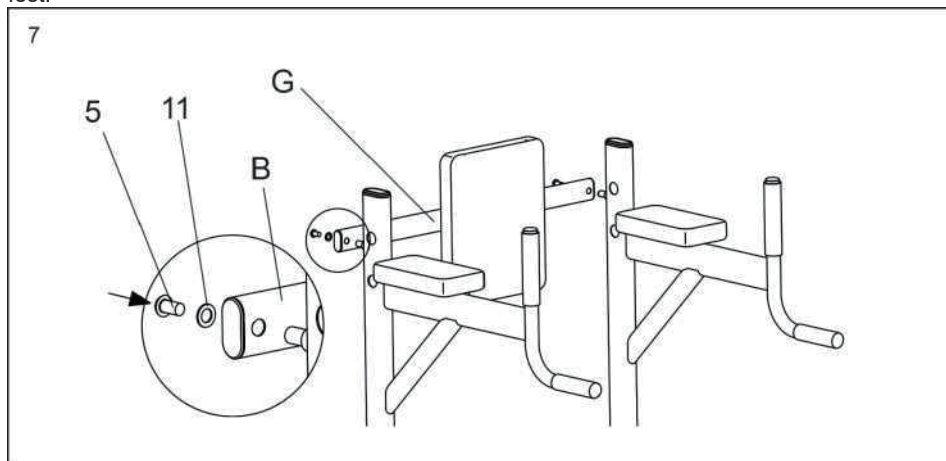

### Schritt 8 Einfache Stange (F) montieren

① Befestigen Sie die einfache Stange (F) mit Innensechskantschrauben M8 \* 80 (3) am Hilfsrohr (C) und ziehen Sie dann die Bogenplatte (12) mit Kontermuttern M8 (8) fest. Hinweis: Richten Sie sie an den Schraubenlöchern aus.

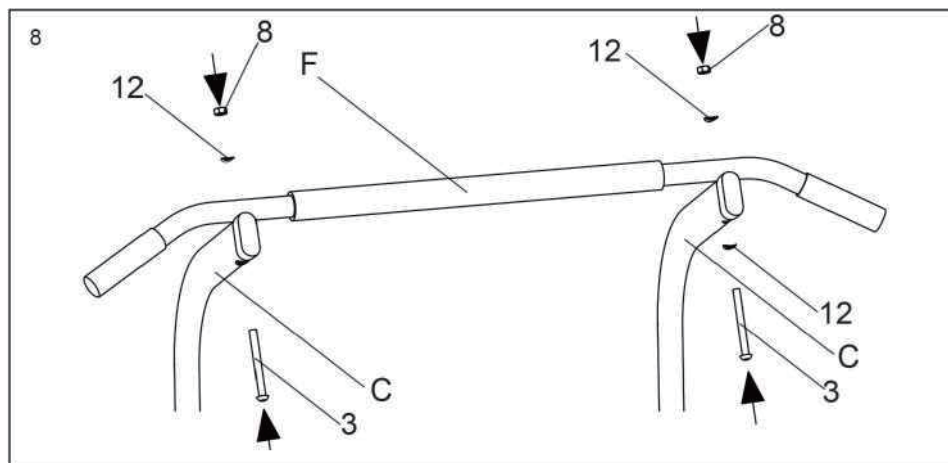

Schritt 9 Installieren Sie das Hilfsrohr (C).

① Setzen Sie das Hilfsrohr (c) auf den oberen Teil des Hauptrahmens (B) und stellen Sie die richtige Höhe ein, um die Schraubenlöcher auszurichten. Ziehen Sie dann die Kunststoff-Griffschraube M8 \* 45 (6) mit den Kunststoff-Griffmutter (7) fest.

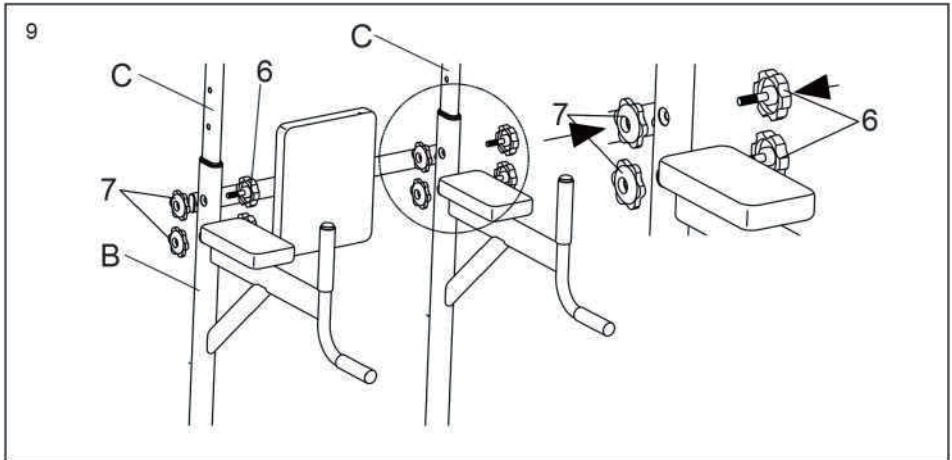

## INSTALLATION ABGESCHLOSSEN

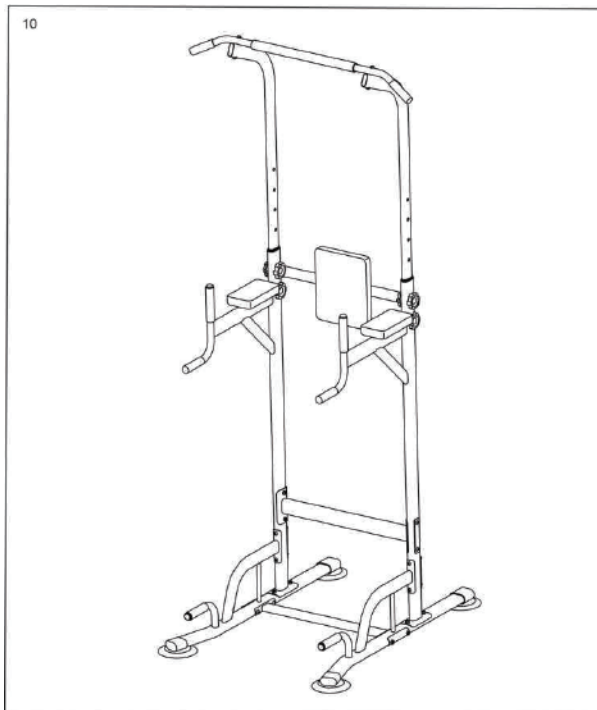

# ZEICHNUNG DER TEILE

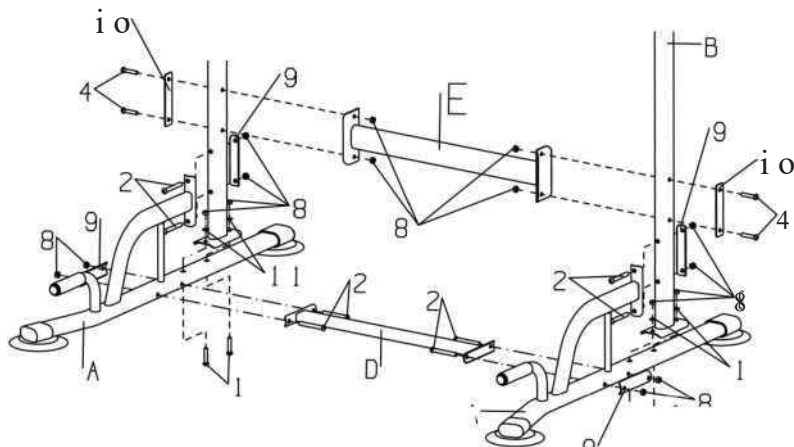
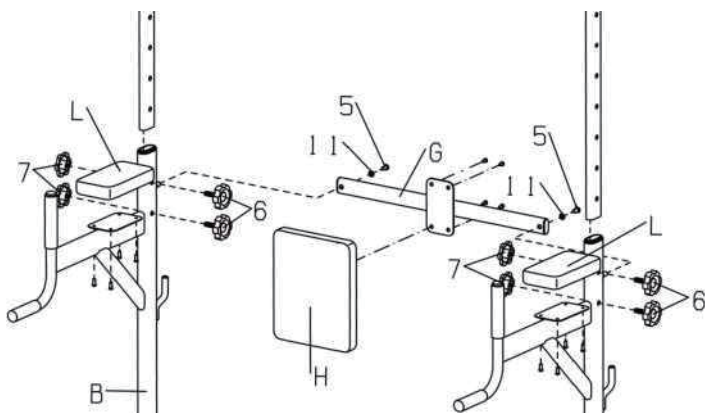
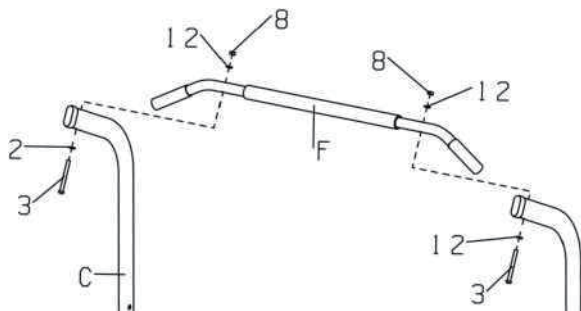

**UK**

If you have any questions, please contact our customer care center.

Our contact details are below:



0044-800-240-4004



enquiries@mhstar.co.uk

IMPORTER ADDRESS:

MH STAR UK LTD  
Unit 27, Perivale Park,  
Horsenden lane South  
Perivale, UB6 7RH  
MADE IN CHINA

**ES**

Si tiene alguna pregunta, comuníquese con nuestro Centro de Atención al Cliente. Nuestros datos de contacto son los siguientes:



0034-931294512



atencioncliente@aosom.es

Importador/Fabricante/REP:

Spanish Aosom, S.L.  
C/ Roc Gros, nº 15. 08550, Els Hostalets de  
Balenyà, Spain.  
B66295775  
www.aosom.es  
atencioncliente@aosom.es  
TEL: 931294512  
HECHO EN CHINA

**FR**

Si vous avez la moindre question, veuillez contacter notre centre d'assistance à la clientèle.

Nos coordonnées sont les suivantes:



0033-1-84166106



aosom@mhfrance.fr

Importé par/Fabricant/REP:

MH France  
2, rue Maurice Hartmann  
92130 Issy-les-Moulineaux  
France  
Fabriqué en Chine

**PT**

Se tiver alguma dúvida, por favor contacte o nosso Centro de Atendimento ao Cliente. Os nossos dados de contacto são os seguintes:



0034-931294512



info@aosom.pt.

IMPORTADOR:

SPANISH AOSOM, S.L  
C.ROC GROS N.15, 08550. ELS HOSTALETS DE BALENYÀ  
TEL: 931294512 (SEG-SEX DAS 7:30H ÀS 16:30H)  
INFO@AOSOM.PT  
WWW.AOSOM.PT

**DE**

Wenn Sie Fragen haben, wenden Sie sich bitte an unser Kundendienstzentrum.

Unsere Kontaktdaten stehen unten:



0049-0(40)-87408465



service@aosom.de

Importeur/Hersteller/REP:

MH Handel GmbH  
Wendenstraße 309  
D-20537 Hamburg  
Germany  
IN CHINA HERGESTELLT

**IT**

In caso di dubbio, si prega di contattare il nostro centro assistenza clienti. I nostri dettagli di contatto sono di seguito:



0039-0249471447



clienti@aosom.it

IMPORTATO DA/Produttore/REP:

AOSOM Italy srl  
Centro Direzionale Milanofiori  
Strada 1 Palazzo F1  
20057 Assago (MI)  
P.I.: 08567220960  
FATTO IN CINA

