

# PawHut

IN241100660V01\_GL

**D00-121\_D00-121V00**

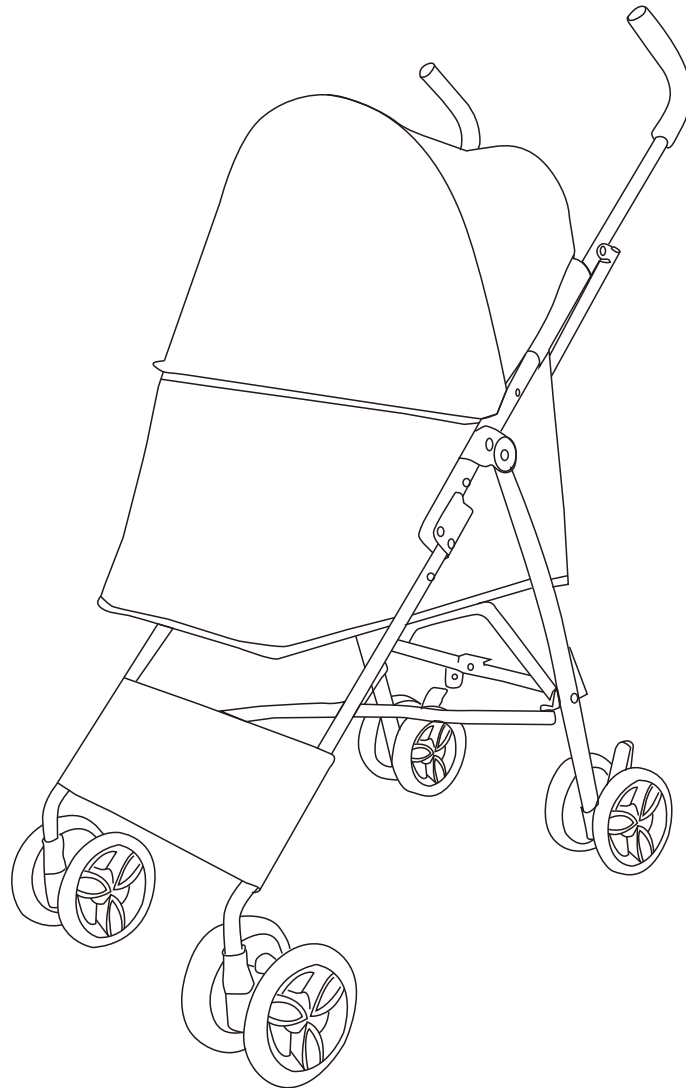

**EN\_ IMPORTANT, RETAIN FOR FUTURE REFERENCE: READ CAREFULLY.**

**FR\_ IMPORTANT: A LIRE ATTENTIVEMENT ET À CONSERVER POUR CONSULTATION ULTÉRIEURE.**

**ES\_ IMPORTANTE, LEA Y GUARDE PARA FUTURAS REFERENCIAS.**

**PT\_ IMPORTANTE, RETER PARA REFERÊNCIA FUTURA: LEIA ATENTAMENTE.**

**DE\_ WICHTIG! SORGFÄLTIG LESEN UND FÜR SPÄTER NACHSCHLAGEN AUFBEWAHREN.**

**IT\_ IMPORTANTE! CONSERVARE IL PRESENTE MANUALE PER FUTURO RIFERIMENTO E LEGGERLO ATTENTAMENTE.**

**WARNING:Keep Away From Fire**

- 1.Please read this instruction carefully before use and keep it properly for future reference. If you do not follow this instruction, the safety of pets may be affected.
- 2.Do not leave the caregiver while the product is in use.
- 3.Do not use accessories not provided by the manufacturer.
- 4.Any load attached to the handle will affect the stability of the pet stroller.
- 5.Ensure that all the locking devices are assembled before using the pet stroller.
- 6.Pets must use restraints when using.
- 7.Do not use the pet stroller in rough areas, near stoves and other dangerous areas.
- 8.Avoid use or storage in damp, cold or high temperature environment and keep away from fire or strong heat source.
- 9.Do not use it to put dangerous animals which are aggressive and destructive.

**Maintenance and Care**

Please check and maintain the pet stroller frequently. The cloth cover cannot be dipped and washed. When the cloth cover is cleaned, please use a brush and other cleaning instruments to clean the dirt.

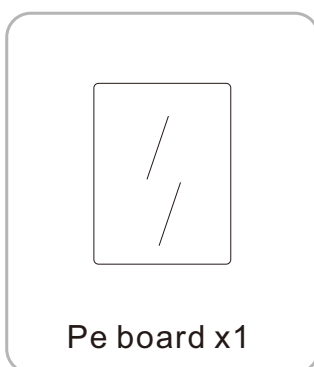
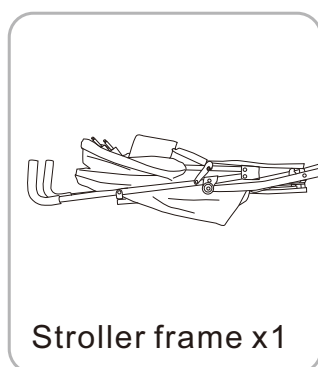
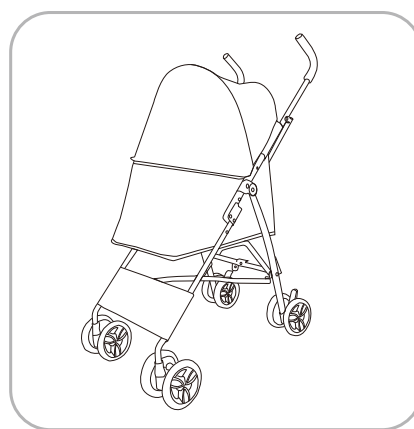
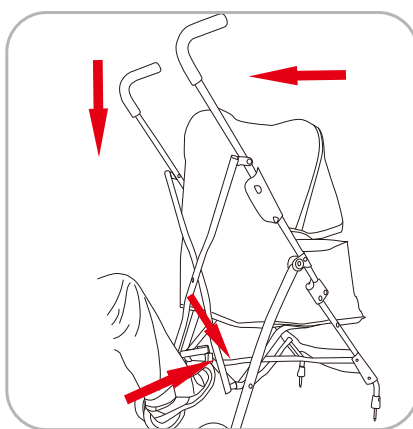
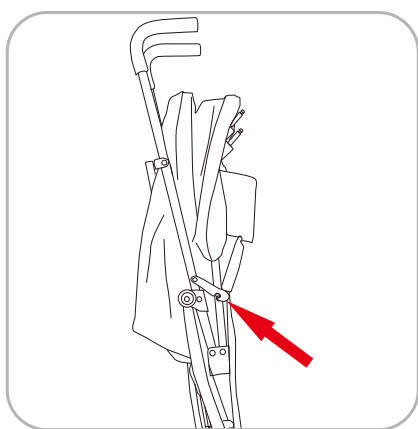
**Parts****Unfolding and folding pet stroller****1.Unfold the frame**

Release the hook, hold the handlebar with both hands and pull it upward and backward, press the locking mechanism by foot, confirm that the locking mechanism is reset . Open the frame and put into the bottom plate and zip up the canopy.

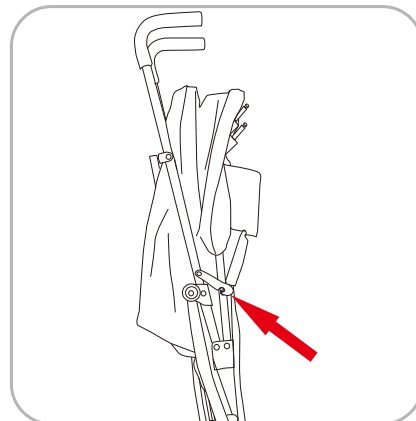
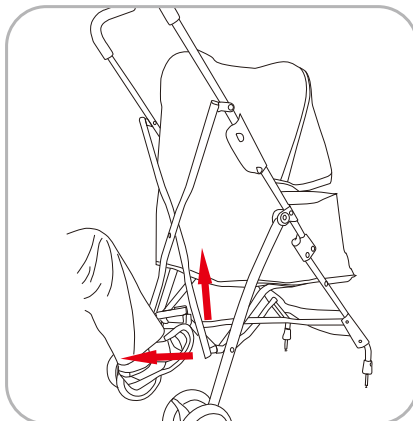

**2. Fold the frame**

In the braking state, take out the bottom plate, hook the locking mechanism outward and upward by foot, hold the handle bar forward and inward to close up. The frame is folded ,then hang the hook.

**Usage of front and rear wheels**

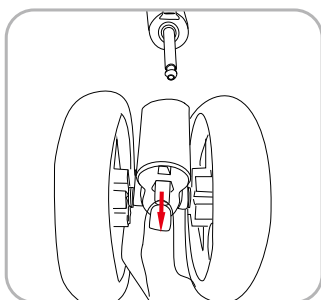
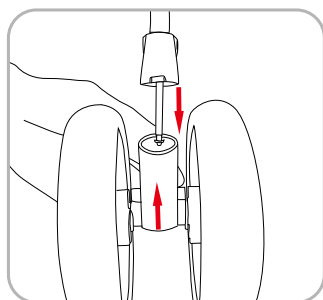

1. Install and disassemble front wheels: Insert the front wheel set into the front wheel seat, it is installed when hear "Click". Press the buckle on the front wheel seat with your hand and pull it down, then the front wheel set is removed.

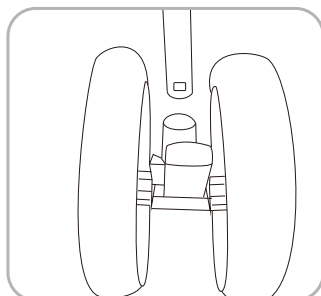
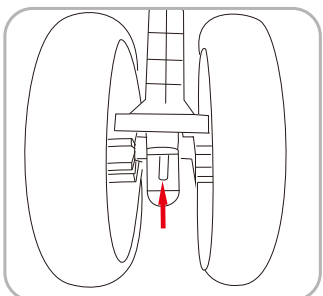

2. Install & disassemble rear wheels : Insert the rear wheel set into the rear wheel seat, it is installed when the barb on the rear wheel seat pops out .Hold the barb on the rear wheel seat and pull it out, the rear wheel set can be removed.

**Usage of other functions**

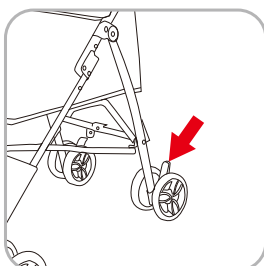

A. Braking: Press down the rear wheel brake levers on both sides  
Moving: Up the rear wheel brake on both sides

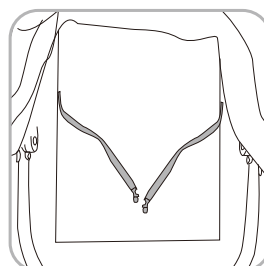

B. For pet safety belt.

**AVERTISSEMENT : À Garder à l'Écart Du Feu**

1. Prière de lire attentivement ces instructions avant l'utilisation et de les conserver pour s'y référer ultérieurement. Le non-respect de ces instructions peut affecter la sécurité des animaux domestiques.
2. Le gardien ne doit pas s'absenter pendant l'utilisation de l'appareil.
3. Ne pas utiliser d'accessoires non fournis par le fabricant.
4. La stabilité de la poussette est affectée par toute charge fixée à la poignée.
5. S'assurer que tous les dispositifs de verrouillage sont assemblés avant d'utiliser la poussette pour animaux.
6. Les animaux domestiques doivent être attachés lors de l'utilisation.
7. Ne pas utiliser la poussette dans des endroits rugueux, à proximité de foyers ou d'autres endroits dangereux.
8. Éviter d'utiliser ou de ranger la poussette dans un environnement humide, froid ou à haute température et la tenir éloignée du feu ou d'une source de chaleur intense.
9. La poussette ne doit pas être utilisée pour transporter des animaux dangereux, agressifs et nuisibles.

**Maintenance et Entretien**

La poussette doit être vérifiée et entretenue fréquemment. La housse en tissu ne doit pas être trempée ni lavée. Lorsque la housse en tissu doit être nettoyée, prière d'utiliser une brosse et d'autres instruments de nettoyage pour enlever la saleté.

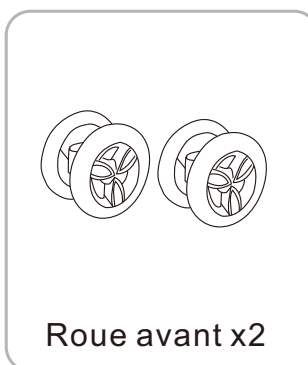
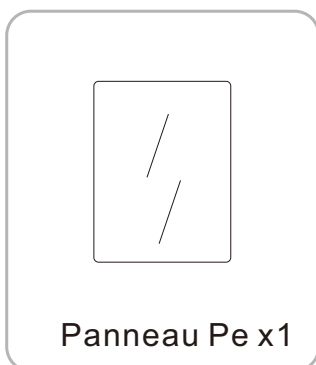
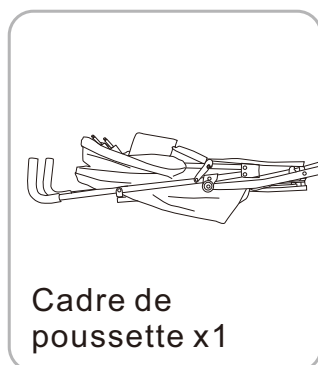
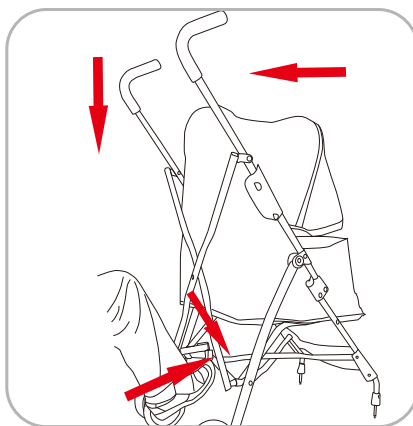
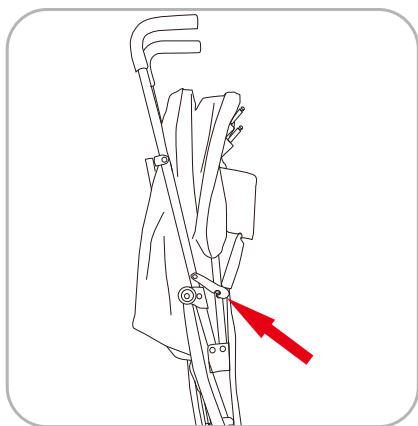
**Pièces****Déplier et plier les chariots pour animaux de compagnie****1. déplier le cadre**

Relâcher le crochet, tenir le guidon à deux mains et le tirer vers le haut et vers l'arrière, appuyer sur le mécanisme de verrouillage avec le pied, confirmer que le mécanisme de verrouillage est réinitialisé. Ouvrez le cadre, mettez-le dans la plaque de fond et fermez la fermeture éclair de la capote.

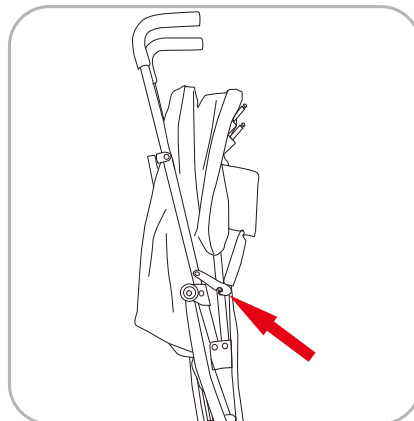
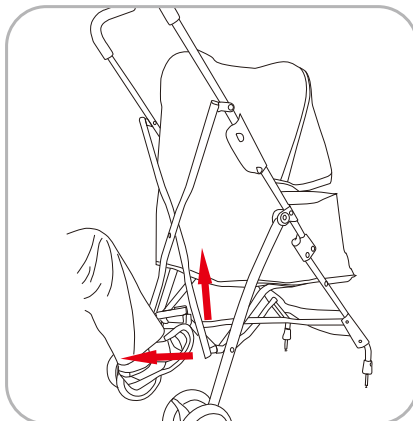

## 2. plier le cadre

En état de freinage, retirer la plaque inférieure, accrocher le mécanisme de verrouillage vers l'extérieur et vers le haut à l'aide du pied, tenir le guidon vers l'avant et vers l'intérieur pour le fermer. Le cadre est plié, puis accroché au crochet.

## Utilisation des roues avant et arrière

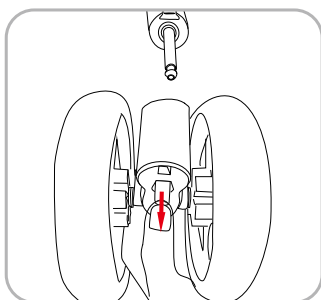
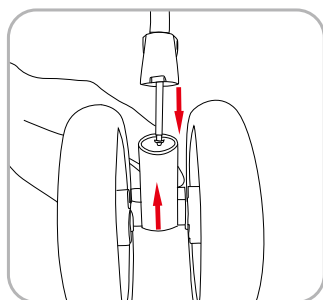

1. installer et démonter les roues avant : Insérer le train de roues avant dans le siège de la roue avant, il est installé lorsqu'on entend le « clic ». Appuyer sur la boucle du siège de la roue avant avec la main et la tirer vers le bas, puis le train de roues avant est enlevé.

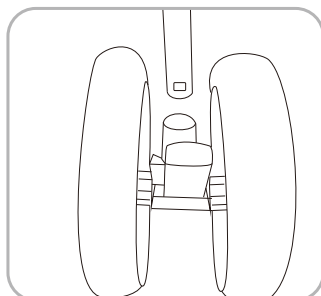
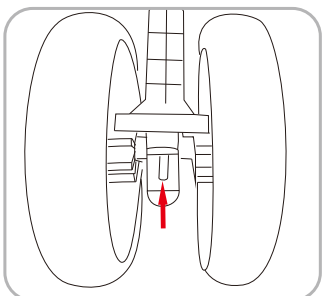

2. Installation et démontage des roues arrière : Insérez l'ensemble de roues arrière dans le siège de la roue arrière, il est installé lorsque l'ardillon sur le siège de la roue arrière sort. tenez l'ardillon sur le siège de la roue arrière et tirez-le, l'ensemble de roues arrière peut être retiré.

## Utilisation d'autres fonctions

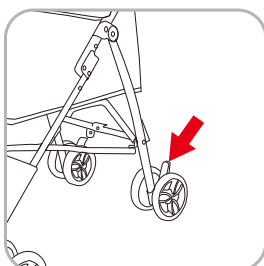

A. Freinage : Appuyer sur les leviers de frein de la roue arrière des deux côtés.  
Déplacement : Relever le frein de la roue arrière des deux côtés

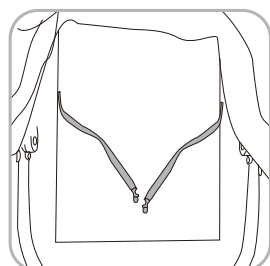

B. Pour la ceinture de sécurité pour animaux de compagnie.

**ADVERTENCIA: Mantener alejado del fuego**

1. Por favor, lea atentamente estas instrucciones antes de usar el aparato y guárdelas para futuras consultas. Si no sigue estas instrucciones, la seguridad de las mascotas puede verse afectada.
2. No deje al cuidador mientras el producto está en uso.
3. No utilice accesorios no proporcionados por el fabricante.
4. Cualquier carga fijada al mango afectará la estabilidad del cochecito para mascotas.
5. Asegúrese de que todos los dispositivos de bloqueo estén montados antes de usar la silla de paseo para mascotas.
6. Los animales domésticos deben ir sujetos cuando se esté usando el producto.
7. No use el cochecito para mascotas en zonas abruptas, cerca de estufas y otras zonas peligrosas.
8. Evite el uso o el almacenamiento en ambientes húmedos, fríos o con altas temperaturas y manténgalo alejado del fuego o de fuentes de calor fuertes.
9. No lo utilice para colocar animales peligrosos que sean agresivos y destructivos.

**Mantenimiento y Cuidado**

Por favor, compruebe y mantenga el cochecito para mascotas con frecuencia. La funda de tela no se puede sumergir ni lavar. Cuando se limpie la cubierta de tela, por favor, utilice un cepillo y otros instrumentos de limpieza para limpiar la suciedad.

**Piezas**



**Silla de paseo para mascotas desplegable y plegable**

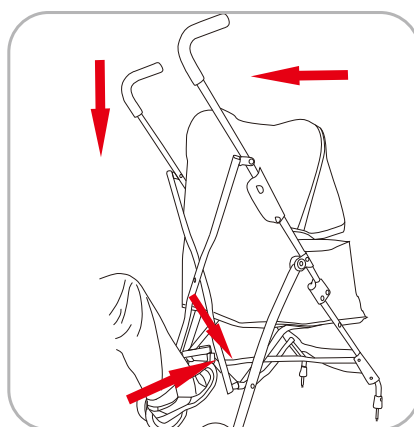
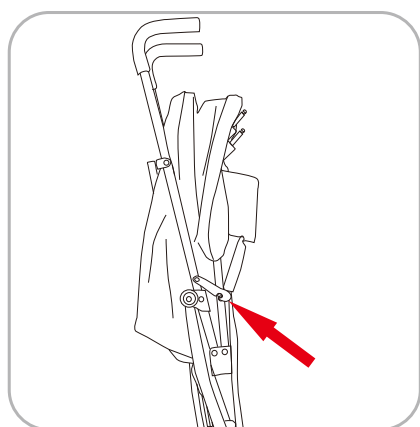

**1. Despliegue el cuadro**

Suelte el gancho, sujete el manillar con ambas manos y tire de él hacia arriba y hacia atrás, presione el mecanismo de bloqueo con el pie, confirme que el mecanismo de bloqueo está restablecido. Abra el cuadro, colóquelo en la placa inferior y suba la cremallera de la capota.

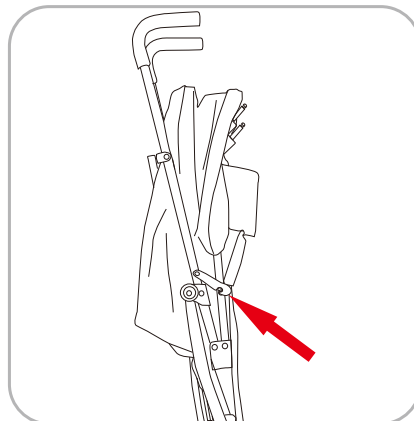
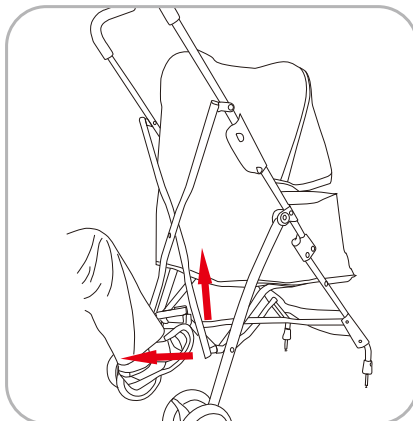

## 2. Plegar el cuadro

En estado de frenado, saque la placa inferior, enganche el mecanismo de bloqueo hacia fuera y hacia arriba con el pie, sujete el manillar hacia delante y hacia dentro para cerrarlo. El bastidor se pliega y cuelga el gancho.

## Uso de las ruedas delanteras y traseras

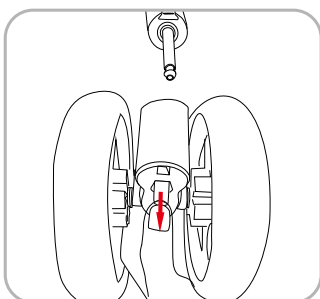
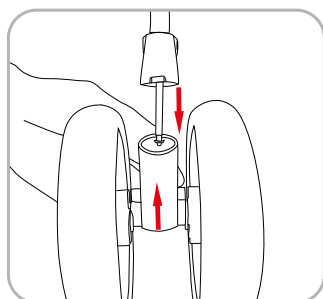

1. Instale y desmonte las ruedas delanteras: Inserte el juego de ruedas delanteras en el asiento de las ruedas delanteras, estará instalado cuando oiga «Click». Presione la hebilla del asiento de las ruedas delanteras con la mano y tire de ella hacia abajo, entonces se retira el juego de ruedas delanteras.

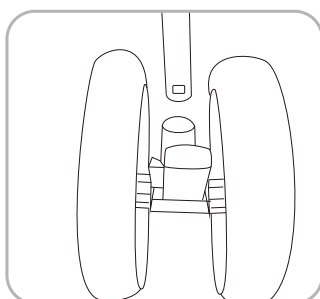
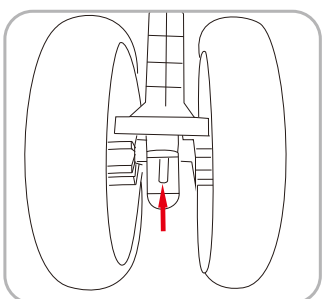

2. Instalación y desmontaje de las ruedas traseras : Inserte el juego de ruedas traseras en el asiento de las ruedas traseras, estará instalado cuando la lengüeta del asiento de las ruedas traseras salte hacia fuera.

## Utilización de otras funciones

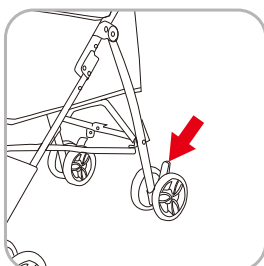

A. Frenado: Presione hacia abajo las palancas de freno de la rueda trasera en ambos lados  
En movimiento: Suba el freno de la rueda trasera en ambos lados

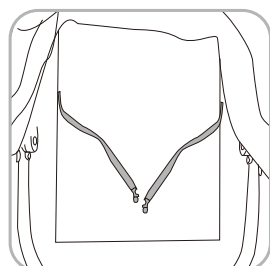

B. Para cinturón de seguridad de mascotas.

**AVISO: Mantenha-se Longe do Fogo**

1. Por favor leia esta instrução cuidadosamente antes de usar e guarde-a devidamente para referência futura. Se não seguir estas instruções, a segurança dos animais de estimação pode ser afetada.
2. Não deixe o prestador de cuidados enquanto o produto estiver em uso.
3. Não utilize acessórios não fornecidos pelo fabricante.
4. Qualquer carga presa à pega afetará a estabilidade do carrinho do animal.
5. Certifique-se de que todos os dispositivos de bloqueio estão montados antes de usar o carrinho de passeio para animais domésticos.
6. Animais de estimação devem usar trelas.
7. Não use o carrinho de passeio em áreas ásperas, perto de fogões e outras áreas perigosas.
8. Evitar o uso ou armazenamento em ambientes húmidos, frios ou de alta temperatura e manter longe de fogo ou fonte de calor forte.
9. Não o utilize para colocar animais perigosos que sejam agressivos e destrutivos.

**Manutenção e Cuidados**

Por favor, verifique e mantenha o carrinho de passeio frequentemente. A cobertura do pano não pode ser mergulhada e lavada. Quando a cobertura do pano for limpa, por favor use uma escova e outros instrumentos de limpeza para limpar a sujidade.

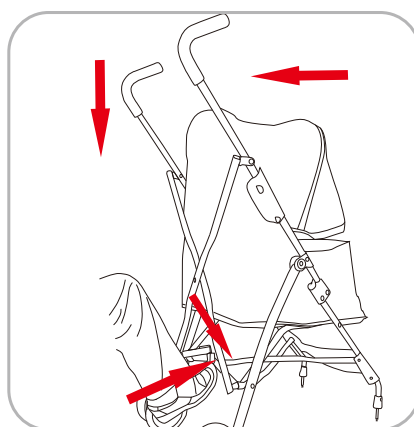
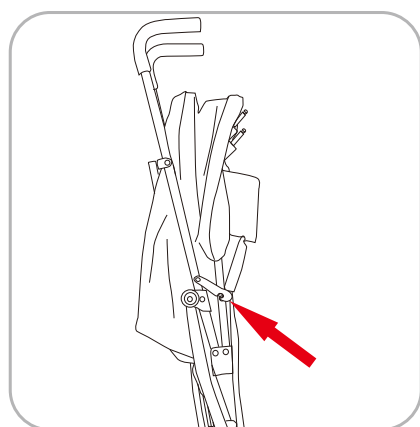
**Partes****Carrinho de passeio desdobrável e dobrável para animais de estimação****1. desdobrar o quadro**

Solte o gancho, segure o guidão com as duas mãos e puxe-o para cima e para trás, pressione o mecanismo de bloqueio com o pé, confirme que o mecanismo de bloqueio é repostado. Abra o quadro, coloque-o na placa inferior e feche o fecho da capota.

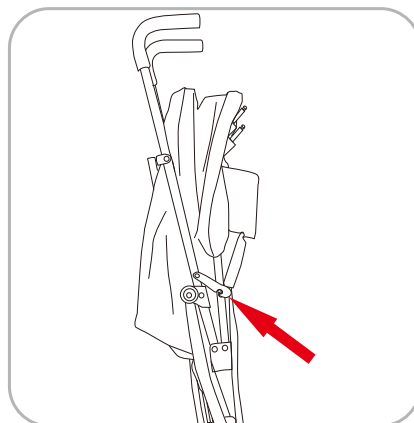
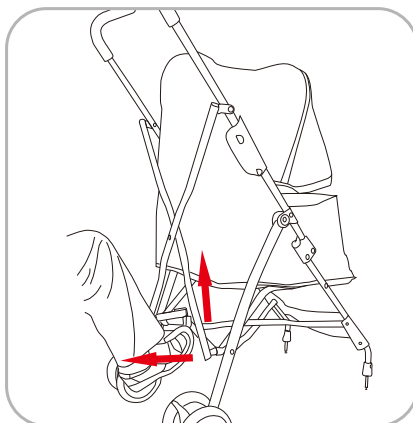
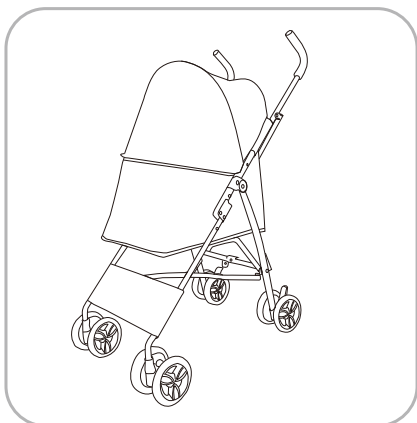

## 2. dobrar o quadro

No estado de travagem, retirar a placa inferior, enganchar o mecanismo de bloqueio para fora e para cima com o pé, segurar o guidador para a frente e para dentro para fechar. O quadro é dobrado e, em seguida, pendurado no gancho.

## Utilização das rodas dianteiras e traseiras

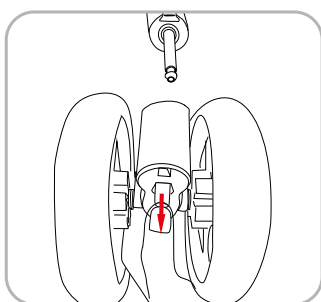
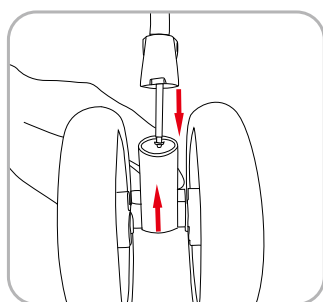

1. Instalar e desmontar as rodas dianteiras: Introduzir o conjunto da roda dianteira no assento da roda dianteira; está instalado quando se ouve um “clique”. Pressionar a fivela do assento da roda dianteira com a mão e puxá-la para baixo; em seguida, o conjunto da roda dianteira é retirado.

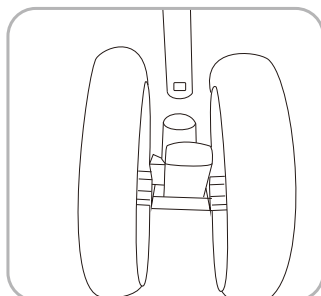
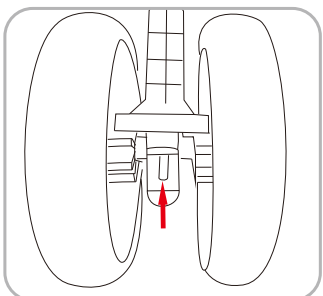

2) Instalar e desmontar as rodas traseiras: Introduzir o conjunto da roda traseira no assento da roda traseira, está instalado quando a espiga no assento da roda traseira salta para fora.

## Utilização de outras funções

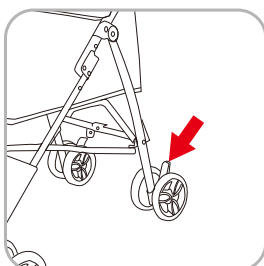

A. Travagem: Pressionar para baixo as alavancas dos travões da roda traseira de ambos os lados  
Em movimento: Subir o travão da roda traseira de ambos os lados

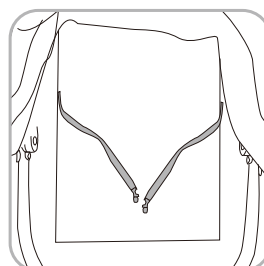

B. Para o cinto de segurança para animais de estimação.

**WARNUNG: Von Feuer fernhalten**

1. Bitte lesen Sie diese Anweisung vor der Verwendung sorgfältig durch und bewahren Sie sie zum späteren Nachschlagen auf. Wenn Sie diese Anweisung nicht befolgen, kann die Sicherheit von Haustieren beeinträchtigt werden.
2. Während der Verwendung des Produkts darf sich die Betreuungsperson nicht entfernen.
3. Verwenden Sie kein Zubehör, das nicht vom Hersteller bereitgestellt wird.
4. Jede an der Lenkstange befestigte Last beeinträchtigt die Stabilität des Hundebuggys.
5. Stellen Sie sicher, dass alle Verriegelungsvorrichtungen vor der Verwendung des Hundebuggys montiert sind.
6. Haustiere müssen bei der Verwendung angeschnallt sein.
7. Verwenden Sie den Hundebuggy nicht in rauen Gegenden, in der Nähe von Öfen oder anderen gefährlichen Bereichen.
8. Verwenden oder lagern Sie ihn nicht in feuchten, kalten oder heißen Umgebungen und halten Sie ihn von Feuer oder starken Wärmequellen fern.
9. Verwenden Sie ihn nicht für gefährliche Tiere, die aggressiv und zerstörerisch sind.

**Wartung und Pflege**

Bitte überprüfen und warten Sie den Hundebuggy regelmäßig. Das Verdeck kann nicht getaucht und gewaschen werden. Wenn Sie das Verdeck reinigen, verwenden Sie bitte eine Bürste und andere Reinigungsmittel, um den Schmutz zu entfernen.

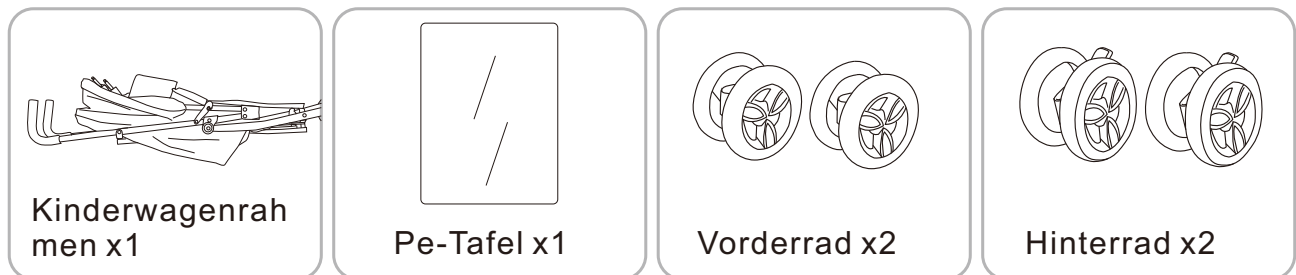
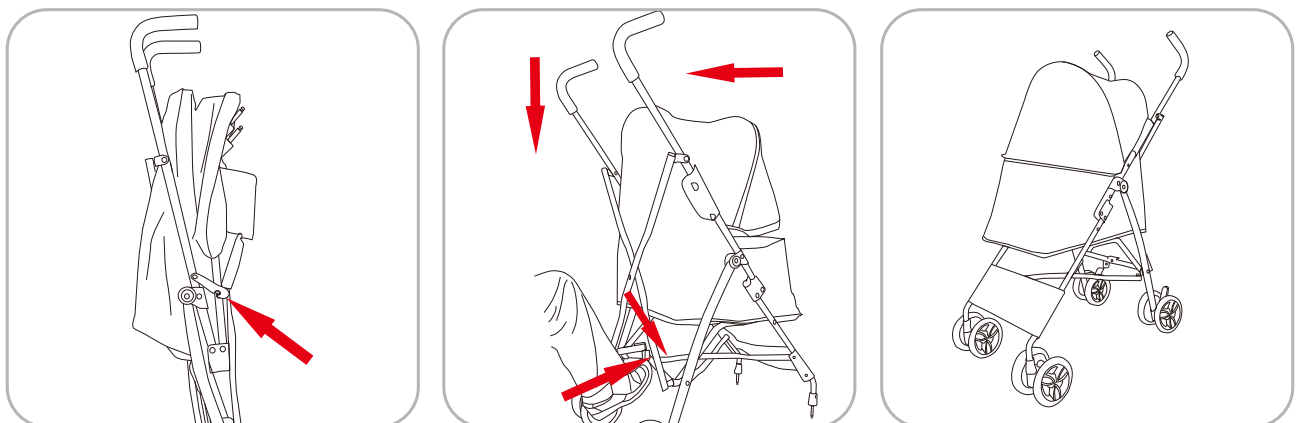
**Teile****Entfalten und Zusammenklappen des Kinderwagens****1. den Rahmen aufklappen**

Lösen Sie den Haken, halten Sie den Lenker mit beiden Händen und ziehen Sie ihn nach oben und nach hinten, drücken Sie den Verriegelungsmechanismus mit dem Fuß, bestätigen Sie, dass der Verriegelungsmechanismus zurückgesetzt ist. Öffnen Sie den Rahmen, legen Sie ihn in die Bodenplatte und schließen Sie den Reißverschluss des Verdecks.

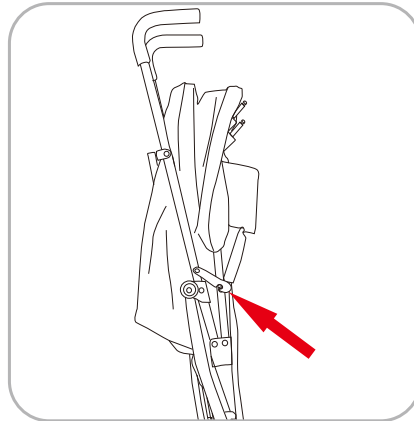
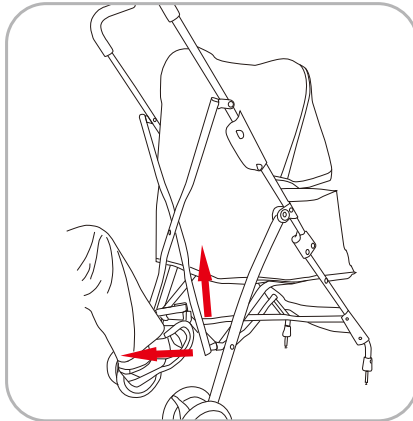

## 2. den Rahmen zusammenklappen

Nehmen Sie im gebremsten Zustand die Bodenplatte heraus, haken Sie den Verriegelungsmechanismus mit dem Fuß nach außen und oben ein, halten Sie den Lenker nach vorne und innen, um ihn zu schließen. Der Rahmen wird zusammengeklappt, dann den Haken einhängen.

## Verwendung von Vorder- und Hinterrädern

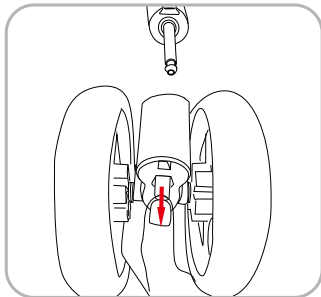
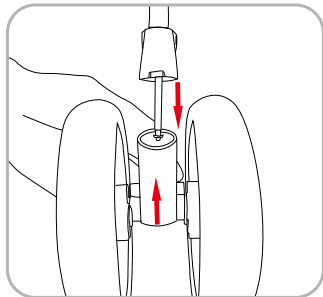

1. montieren und demontieren Sie die Vorderräder: Setzen Sie den Vorderradsatz in den Vorderradsitz ein, er ist eingebaut, wenn Sie „Klick“ hören. Drücken Sie die Schnalle am Vorderradsitz mit der Hand und ziehen Sie sie nach unten, dann wird der Vorderradsatz entfernt.

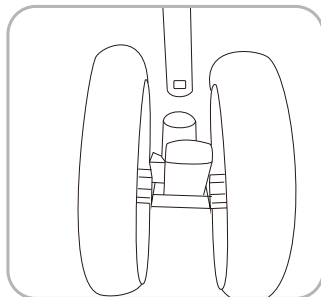
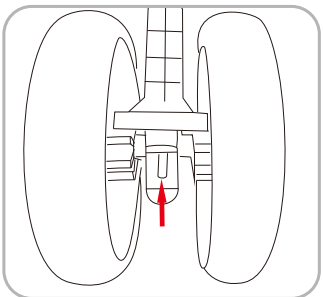

2. montieren und demontieren Sie die Hinterräder: Stecken Sie den Hinterradsatz in den Hinterradsitz, er ist montiert, wenn der Widerhaken am Hinterradsitz herauspringt. Halten Sie den Widerhaken am Hinterradsitz und ziehen Sie ihn heraus, der Hinterradsatz kann entfernt werden.

## Verwendung anderer Funktionen

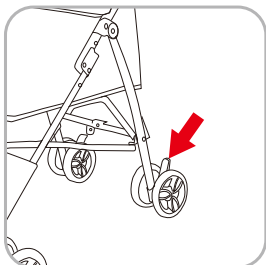

A. Bremsen: Drücken Sie die Hinterradbremshebel auf beiden Seiten herunter.  
Bewegen: Die Hinterradbremse auf beiden Seiten hochziehen

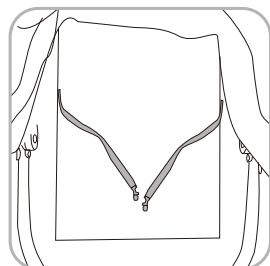

B. Für den Sicherheitsgurt für Haustiere.

**AVVERTENZA: Tenere lontano dal fuoco**

1. Si prega di leggere attentamente le presenti istruzioni prima dell'uso e di conservarle per future consultazioni. Se non si seguono queste istruzioni, la sicurezza degli animali domestici potrebbe essere compromessa.
2. Non lasciare andare la persona che assiste quando il prodotto è in uso.
3. Non utilizzare accessori non forniti dal produttore.
4. Qualsiasi carico attaccato alla maniglia influisce sulla stabilità del passeggino.
5. Assicurarsi che tutti i dispositivi di bloccaggio siano montati prima di utilizzare il passeggino.
6. Gli animali domestici devono essere trattenuti durante l'uso.
7. Non utilizzare il passeggino in zone impervie, vicino a stufe o altre aree pericolose.
8. Evitare l'uso o lo stoccaggio in ambienti umidi, freddi o ad alta temperatura e tenerlo lontano dal fuoco o da fonti di calore forte.
9. Non utilizzarlo per animali pericolosi, aggressivi e distruttivi.

**Manutenzione e Cura**

Controllare e mantenere frequentemente il passeggino per animali domestici. Il rivestimento in tessuto non può essere immerso in liquido e lavato. Quando si pulisce il rivestimento in tessuto, utilizzare una spazzola e altri strumenti di pulizia per pulire lo sporco.

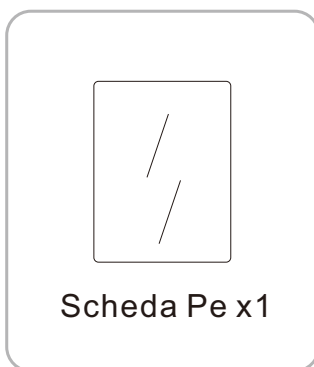
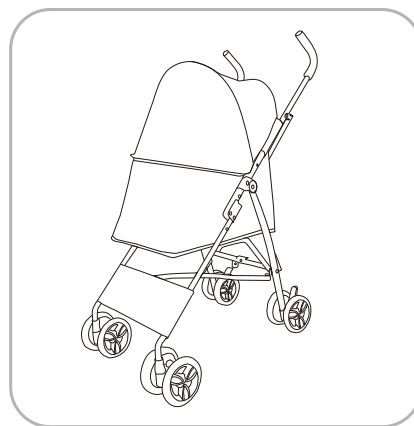
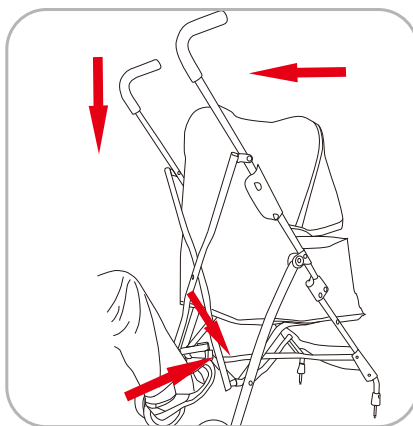
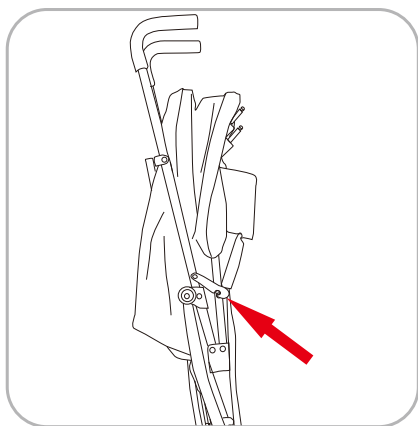
**Parti di ricambio****Passeggino per animali da compagnia pieghevole e ripiegabile****1. Aprire il telaio**

Rilasciare il gancio, afferrare il manubrio con entrambe le mani e tirarlo verso l'alto e all'indietro, premere il meccanismo di bloccaggio con il piede, verificare che il meccanismo di bloccaggio sia ripristinato. Aprire il telaio, inserirlo nella piastra inferiore e chiudere la capottina.

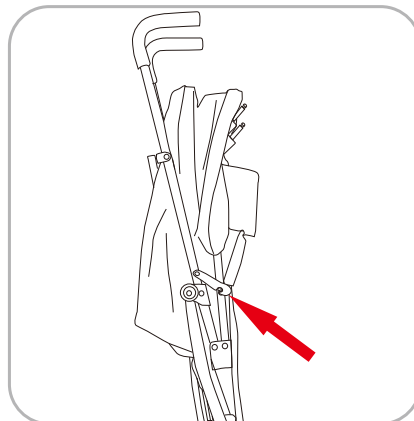
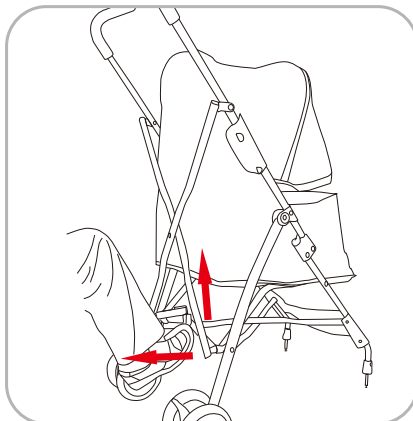

## 2. Piegare il telaio

In fase di frenata, estrarre la piastra inferiore, agganciare il meccanismo di bloccaggio verso l'esterno e verso l'alto con il piede, tenere la barra della maniglia in avanti e verso l'interno per chiuderla. Il telaio è piegato, quindi appendere il gancio.

## Utilizzo delle ruote anteriori e posteriori

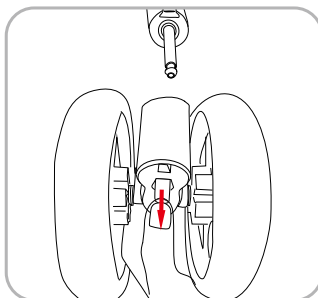
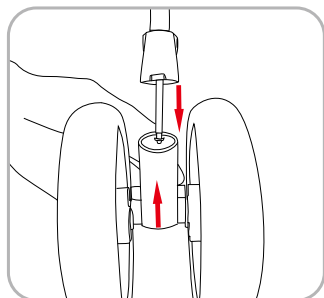

1. Installare e smontare le ruote anteriori: Inserire il set di ruote anteriori nella sede delle ruote anteriori, è installato quando si sente "Click". Premere con la mano la fibbia sulla sede delle ruote anteriori e tirarla verso il basso, quindi rimuovere il set di ruote anteriori.

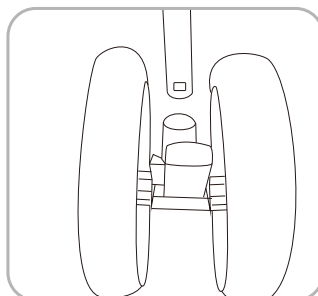
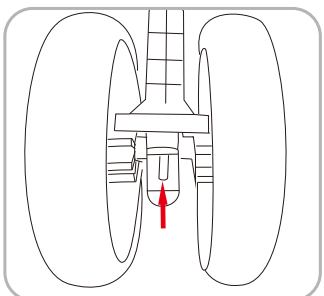

2. Installare e smontare le ruote posteriori: inserire il set di ruote posteriori nella sede della ruota posteriore, è installato quando l'asta sulla sede della ruota posteriore fuoriesce. Tenere l'asta sulla sede della ruota posteriore e tirarla fuori, il set di ruote posteriori può essere rimosso.

## Utilizzo di altre funzioni

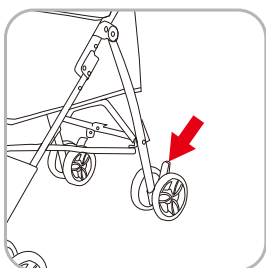

A. Frenata: Premere le leve del freno della ruota posteriore su entrambi i lati.

Spostamento: Alzare il freno della ruota posteriore su entrambi i lati

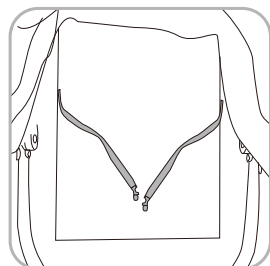

B. Per la cintura di sicurezza per animali domestici.

If you have any questions, please contact our customer care center, Our contact details are below:

**US**

 001-877-644-9366

 customerservice@aosom.com

Imported by Aosom LLC  
27150 SW Kinsman Rd Wilsonville, OR 97070 USA  
MADE IN CHINA

If you have any questions, please contact our customer care center, Our contact details are below:

**CA**

 416-792-6088

 customerservice@aosom.ca

Imported by Aosom Canada Inc.  
7270 Woodbine Avenue, Unit 307, Markham,  
Ontario Canada L3R 4B9  
MADE IN CHINA

Si vous avez la moindre question, veuillez contacter notre centre d'assistance à la clientèle, Nos coordonnées sont les suivantes:

 416-792-6088

 customerservice@aosom.ca

Importé par Aosom Canada Inc.  
7270 Woodbine Avenue, unité 307,  
Markham, Ontario Canada L3R 4B9  
FABRIQUÉ EN CHINE

If you have any questions, please contact our customer care center, Our contact details are below:

**UK**

 0044-800-240-4004

 enquiries@mhstar.co.uk

IMPORTER ADDRESS:  
MH STAR UK LTD  
Unit 27, Perivale Park,  
Horsenden lane South  
Perivale, UB6 7RH  
MADE IN CHINA

Si vous avez la moindre question, veuillez contacter notre centre d'assistance à la clientèle, Nos coordonnées sont les suivantes:

**FR**

 0033-1-84166106

 aosom@mhfrance.fr

Importé par/Fabricant/REP:  
MH FRANCE  
2 Rue Maurice Hartmann  
92130 Issy Les Moulineaux  
France  
FABRIQUÉ EN CHINE

Wenn Sie Fragen haben, wenden Sie sich bitte an unser Kundendienstzentrum, Unsere Kontaktdaten stehen unten:

**DE**

 0049-0(40)-87408465

 service@aosom.de

ADRESSE DES IMPORTEURE/Hersteller/REP:  
MH Handel GmbH  
Wendenstraße 309  
D-20537 Hamburg  
Germany  
IN CHINA HERGESTELLT

In caso di dubbio, si prega di contattare il nostro centro assistenza clienti, I nostri dettagli di contatto sono di seguito:

**IT**

 0039-0249471447

 clienti@aosom.it

IMPORTATO DA/Produttore/REP:  
AOSOM Italy srl  
Centro Direzionale Milanofiori  
Strada 1 Palazzo F1  
20057 Assago (MI)  
P.I.: 08567220960  
FATTO IN CINA

Si tiene alguna pregunta, comuníquese con nuestro Centro de Atención al Cliente, Nuestros datos de contacto son los siguientes:

**ES**

 0034-931294512

 atencioncliente@aosom.es

IMPORTADOR/Fabricante/REP:  
SPANISH AOSOM, S.L.  
C/ROC GROS, N°15.08550, ELS HOSTALETES DE  
BALENYÀ, SPAIN.  
B66295775  
HECHO EN CHINA

Se tiver alguma dúvida, por favor contacte o nosso Centro de Atendimento ao Cliente, Os nossos dados de contacto são os seguintes:

 0034-931294512

 info@aosom.pt.

IMPORTADOR/Fabricante/REP:  
SPANISH AOSOM, S.L.  
C.ROC GROS N.15, 08550. ELS HOSTALETES DE  
BALENYÀ  
FEITO NA CHINA



**FR**

**DONNEZ  
OU  
RECYCLEZ**



ASSOCIATION

OU



LIVRAISON

OU



DÉCHÈTERIE

Adresses sur [quefairedemesdechets.fr](http://quefairedemesdechets.fr)