

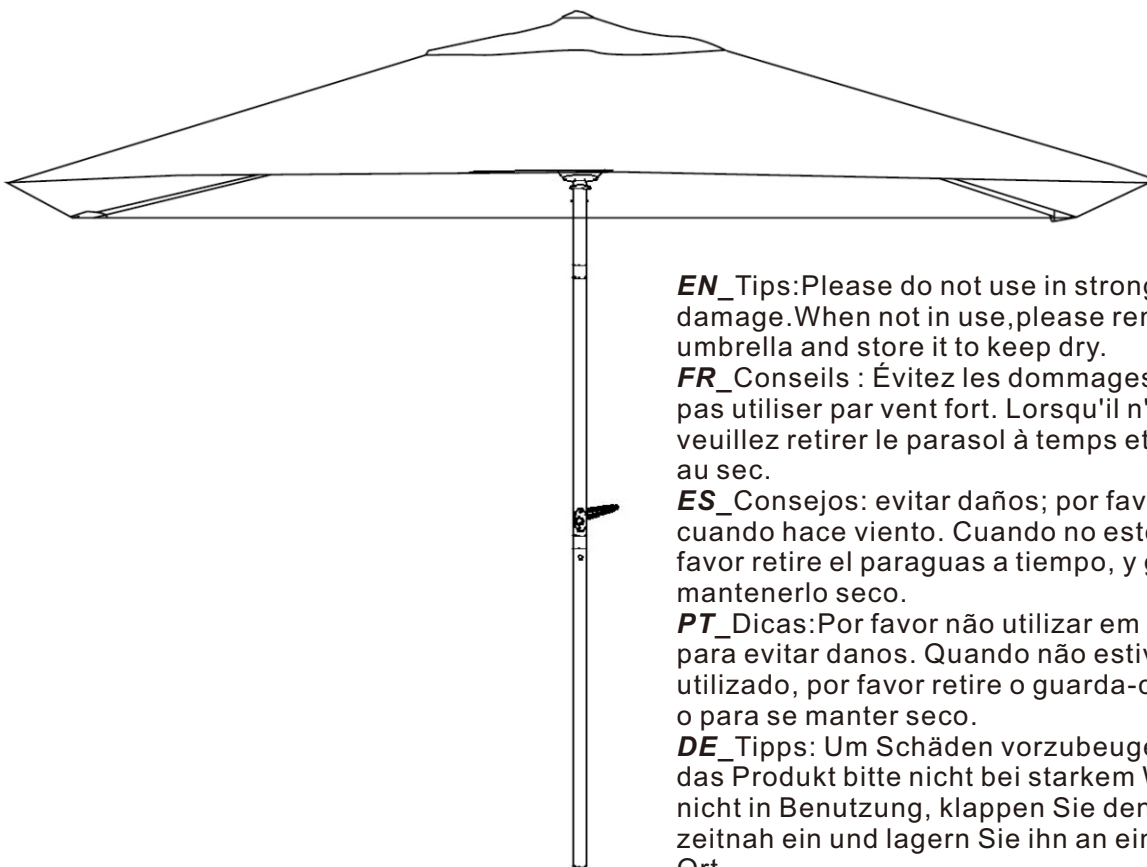

IN221100884V01_GL

84D-158_84D-158V00_84D-158V01



EN_Tips: Please do not use in strong winds to avoid damage. When not in use, please remove the umbrella and store it to keep dry.

FR_Conseils : Évitez les dommages, veuillez ne pas utiliser par vent fort. Lorsqu'il n'est pas utilisé, veuillez retirer le parasol à temps et conservez-le au sec.

ES_Consejos: evitar daños; por favor, no use cuando hace viento. Cuando no esté en uso: por favor retire el paraguas a tiempo, y guárdelo para mantenerlo seco.

PT_Dicas: Por favor não utilizar em ventos fortes para evitar danos. Quando não estiver a ser utilizado, por favor retire o guarda-chuva e guarde-o para se manter seco.

DE_Tipps: Um Schäden vorzubeugen, nutzen Sie das Produkt bitte nicht bei starkem Wind. Wenn nicht in Benutzung, klappen Sie den Schirm bitte zeitnah ein und lagern Sie ihn an einem trockenen Ort.

IT_Suggerimenti: evitare danni, si prega di non utilizzare quando fuori C'è vento. Quando non in uso, si prega di rimuovere l'ombrello tempestivamente e conservare per tenerlo asciutto.

EN_IMPORTANT, RETAIN FOR FUTURE REFERENCE: READ CAREFULLY.

FR_IMPORTANT: A LIRE ATTENTIVEMENT ET À CONSERVER POUR CONSULTATION ULTÉRIEURE.

ES_IMPORTANTE, LEA Y GUARDE PARA FUTURAS REFERENCIAS.

PT_IMPORTANTE, RETER PARA REFERÊNCIA FUTURA: LEIA ATENTAMENTE.

DE_WICHTIG! SORGFÄLTIG LESEN UND FÜR SPÄTER NACHSCHLAGEN AUFBEWAHREN.

IT_IMPORTANTE! CONSERVARE IL PRESENTE MANUALE PER FUTURO RIFERIMENTO E LEGGERLO ATTENTAMENTE.

A x 1

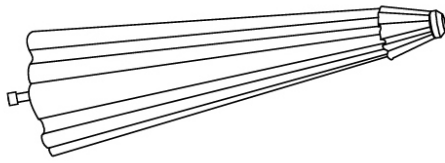

B x 1



01

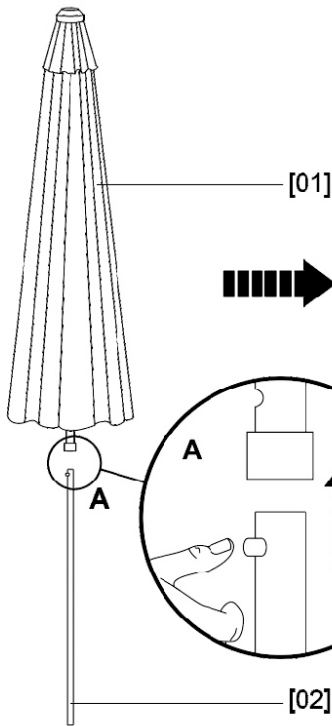

[01]

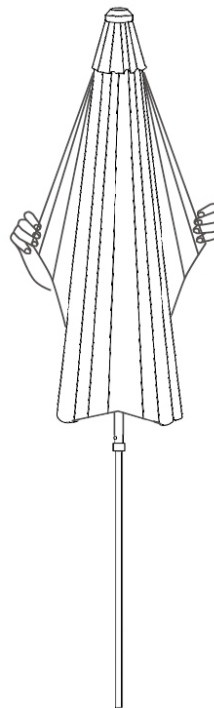
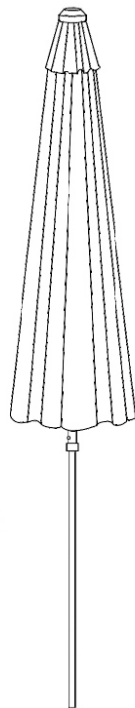

EN Before open the umbrella, pls stretch the short ribs out to ensure it did not stuck in.

FR Avant d'ouvrir le parapluie, étirez les côtes courtes pour vous assurer qu'elles ne sont pas coincées.

ES Antes de abrir el paraguas, estire las costillas para asegurarse de que no se atascan.

DE Bevor Sie den Schirm öffnen, strecken Sie die kurzen Rippen aus, um sicherzustellen, dass sie nicht eingeklemmt sind.

IT Prima di aprire l'ombrello, allungare le costole per assicurarsi che non rimangano incastrate.



[02]

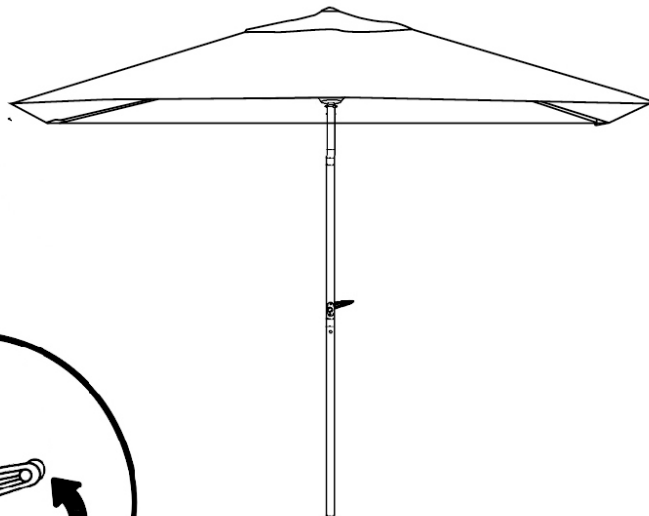
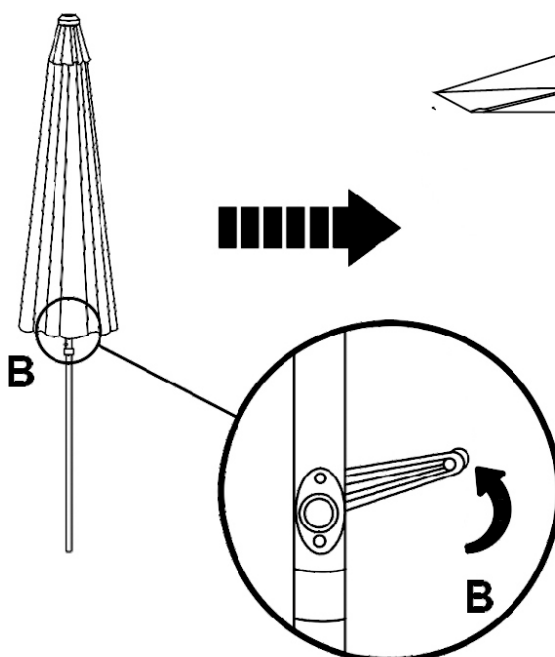

02

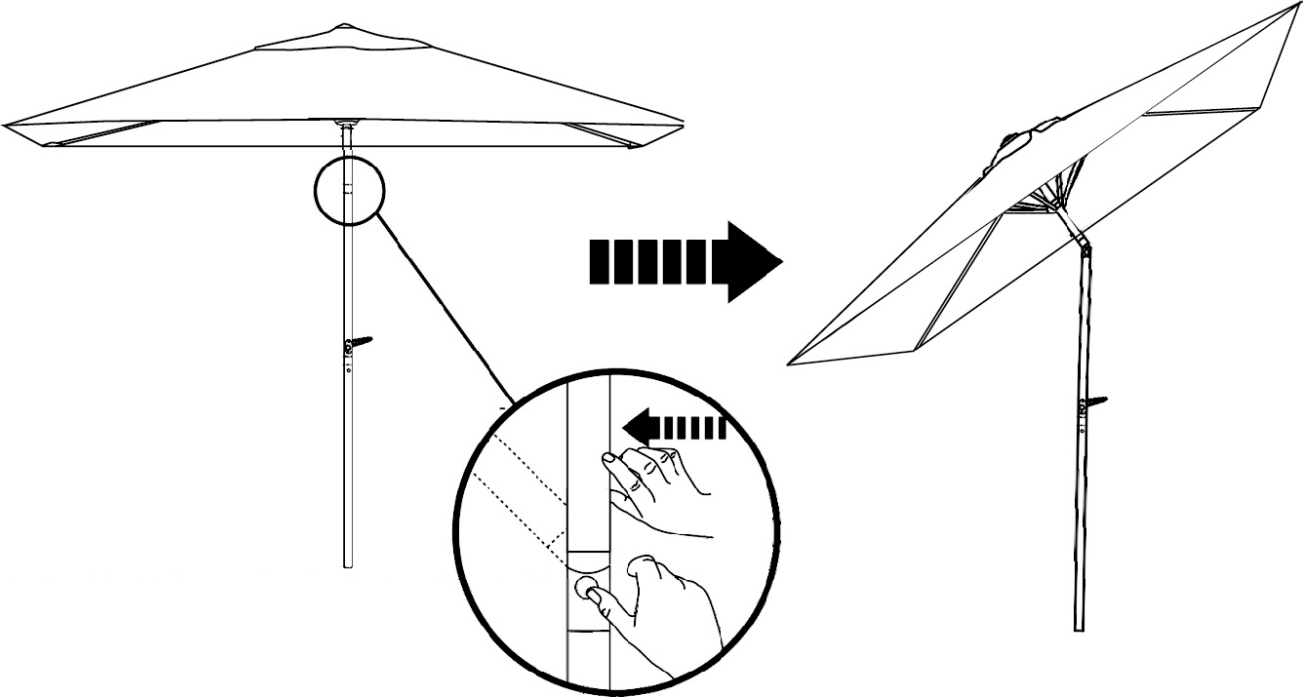



Done



If you have any questions, please contact our customer care center. **US**
Our contact details are below:
 001-877-644-9366
 customerservice@aosom.com
Imported by Aosom LLC
27150 SW Kinsman Rd Wilsonville, OR 97070 USA
MADE IN CHINA

Si tiene alguna pregunta, comuníquese con nuestro Centro de Atención al Cliente. **ES**
Nuestros datos de contacto son los siguientes:
 0034-931294512
 atencioncliente@aosom.es
IMPORTADOR:
SPANISH AOSOM, S.L.
C/ ROC GROS, Nº 15. 08550, ELS HOSTALETES DE BALENYÀ, SPAIN.
B66295775
WWW.AOSOM.ES
HECHO EN CHINA



If you have any questions, please contact our customer care center. **CA**
Our contact details are below:
 416-792-6088
 customerservice@aosom.ca
Imported by Aosom Canada Inc.
7270 Woodbine Avenue, Unit 307, Markham, Ontario Canada L3R 4B9
MADE IN CHINA

Se tiver alguma dúvida, por favor contacte o nosso Centro de Atendimento ao Cliente. **PT**
Os nossos dados de contacto são os seguintes:
 0034-931294512 (SEG-SEX DAS 7:30H ÀS 16:30H)
 info@aosom.pt.
IMPORTADOR:
SPANISH AOSOM, S.L
C.ROC GROS N.15, 08550. ELS HOSTALETES DE BALENYÀ
WWW.AOSOM.PT

Si vous avez la moindre question, veuillez contacter notre centre d'assistance à la clientèle. **FR**
Nos coordonnées sont les suivantes:
 416-792-6088
 customerservice@aosom.ca
Importé par Aosom Canada Inc.
7270 Woodbine Avenue, unité 307, Markham, Ontario Canada L3R 4B9
Fabriqué en Chine

Wenn Sie Fragen haben, wenden Sie sich bitte an unser Kundendienstzentrum. **DE**
Unsere Kontaktdaten stehen unten:
 0049-0(40)-88307530  service@aosom.de
ADRESSE DES IMPORTEUR:
MH Handel GmbH
Wendenstraße 309
D-20537 Hamburg
Germany
IN CHINA HERGESTELLT

If you have any questions, please contact our customer care center. **UK**
Our contact details are below:
 0044-800-240-4004
 enquiries@mhstar.co.uk
IMPORTER ADDRESS:
MH STAR UK LTD
Unit 27, Perivale Park,
Horsenden lane South
Perivale, UB6 7RH
MADE IN CHINA

In caso di dubbio, si prega di contattare il nostro centro assistenza clienti. **IT**
I nostri dettagli di contatto sono di seguito:
 0039-0249471447  clienti@aosom.it
IMPORTATO DA:
AOSOM Italy srl
Centro Direzionale Milanofiori
Strada 1 Palazzo F1
20057 Assago (MI)
P.I.: 08567220960
FATTO IN CINA

Si vous avez la moindre question, veuillez contacter notre centre d'assistance à la clientèle. **FR**
Nos coordonnées sont les suivantes:  0033-1-84166106  aosom@mhfrance.fr
Importé par: MH France 2, rue Maurice Hartmann 92130 Issy-les-Moulineaux
Fabriqué en Chine
France



Adresses sur quefairedemesdechets.fr