

AIYAPLAY

IN240900132V01_UK_FR_DE_ES_PT_IT

331-083V00

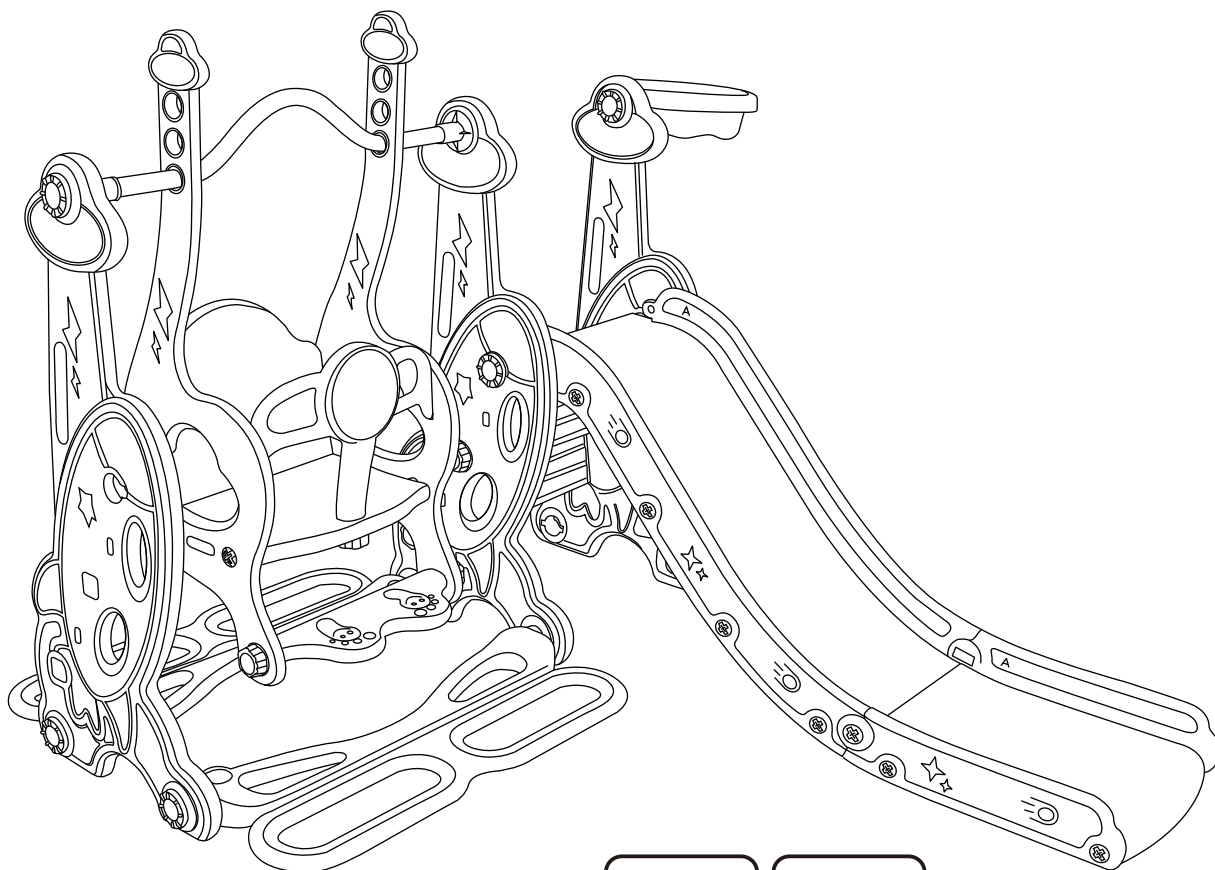

13
STEPS



EN_WARNING: Suitable for children of 18+ months; Max weight: 30 kg.

FR_ATTENTION: Convient aux enfants de 18+ mois; Poids maximum: 30 kg.

DE_ACHTUNG: Geeignet für Kinder im Alter von 18+ Monate; Max. Gewicht: 30 kg.

ES_ADVERTENCIA: Adecuado para los niños de 18+ meses; Peso máximo: 30 kg.

PT_ADVERTÊNCIA: Adequado para crianças de 18+ meses; Peso máximo: 30 kg.

IT_AVVERTENZA: Adatto a bambini di 18+ mesi; Peso massimo: 30 kg.

EN_IMPORTANT, RETAIN FOR FUTURE REFERENCE: READ CAREFULLY.

FR_IMPORTANT : A LIRE ATTENTIVEMEN ET A CONSERVER POUR VOUS Y REFERER ULTERIEUREMENT.

ES_IMPORTANTE, LEA Y GUARDE PARA FUTURAS REFERENCIAS.

PT_IMPORTANTE, RETER PARA REFERÊNCIA FUTURA: LEIA ATENTAMENTE.

DE_WICHTIG! SORGFÄLTIG LESEN UND FÜR SPÄTER NACHSCHLAGEN AUFBEWAHREN.

IT_IMPORTANTE! CONSERVARE IL PRESENTE MANUALE PER FUTURO RIFERIMENTO E LEGGERLO ATTENTAMENTE.

WARNING:

1. Only allowed for adults to install, keep children away.
2. To be used under the direct supervision of an adult.
3. Check all the parts are well connected before use.
4. Regularly check and maintain the main components (suspenders, fasteners, fixings, etc.), otherwise the swing may tip over or cause a fall.
5. Installation area should be as wide as possible, flat and avoid dampness.
6. Keep away from fire.

MAINTENANCE

1. Please wipe the surface stains of product with a dry cloth. If necessary, use mild soap or detergent to clean them. After wiping with a soft wet cloth, wipe them with a dry cloth. Do not use a strong acid-alkaline cleaning solution to clean them.
2. If not used for a long time, please put it in a cool and dry place and cover it with clean cloth or blanket.

ATTENTION:

1. Installation par des adultes exclusivement, ne pas laisser les enfants s'approcher.
2. Surveillance permanente par un adulte lors de l'utilisation.
3. Vérifiez que toutes les pièces sont bien connectées avant utilisation.
4. Vérifiez et entretenez régulièrement les principaux composants (suspensions, attaches, fixations, etc.), sinon la balançoire peut basculer ou provoquer une chute.
5. La zone d'installation doit être aussi large que possible, plate et non humide.
6. Tenir à l'écart du feu.

ENTRETIEN

1. Veuillez essuyer les taches de surface sur le produit avec un chiffon sec. Si nécessaire, utilisez un savon doux ou un détergent pour les nettoyer. Après les avoir essuyées avec un chiffon doux et humide, essuyez-les avec un chiffon sec. N'utilisez pas de solution de nettoyage acide ou alcaline forte pour les nettoyer.
2. Si vous ne l'utilisez pas pendant une longue période, rangez-le dans un endroit frais et sec et couvrez-le d'un tissu ou d'une couverture propre.



Adresses sur quefairedemesdechets.fr

ACHTUNG:

1. Darf nur von Erwachsenen installiert werden, halten Sie Kinder fern.
2. Nur unter der direkten Aufsicht eines Erwachsenen verwenden.
3. Prüfen Sie vor dem Gebrauch, ob alle Teile gut miteinander verbunden sind.
4. Überprüfen und warten Sie regelmäßig die Hauptbauteile (Aufhängungen, Verschlüsse, Befestigungen usw.), sonst kann die Schaukel umkippen oder einen Sturz verursachen.
5. Die Aufstellfläche sollte so breit wie möglich und flach sein und Feuchtigkeit vermeiden.
6. Von Feuer fernhalten.

WARTUNG

1. Bitte wischen Sie die Oberflächenflecken des Produkts mit einem trockenen Tuch ab. Falls erforderlich, verwenden Sie milde Seife oder Reinigungsmittel, um sie zu reinigen. Nach dem Abwischen mit einem weichen, feuchten Tuch, wischen Sie sie mit einem trockenen Tuch ab. Verwenden Sie zum Reinigen keine stark säurehaltige oder alkalische Reinigungslösung.
2. Wenn sie längere Zeit nicht benutzt wird, stellen Sie sie bitte an einen kühlen und trockenen Ort und decken Sie sie mit einem sauberen Tuch oder einer Decke ab.

ADVERTENCIA:

1. Sólo puede ser montado e instalado por un adulto, mantenga a los niños alejados del área de instalación.
2. Debe ser utilizado bajo la supervisión directa de un adulto.
3. Compruebe si todas las piezas estén conectadas bien antes de utilizarlo.
4. Inspeccione y realice mantenimiento para los componentes principales regularmente (tirantes, sujetadores, fijaciones, etc.), de lo contrario, el columpio puede volcarse o causar una caída.
5. El área para realizar la instalación debe ser lo más amplia posible, nivelada y puede evitar la humedad.
6. Mantenga el columpio y tobogán infantil alejado del fuego.

MANTENIMIENTO

1. Limpie las manchas en superficie del columpio y tobogán infantil con un paño seco. Si es necesario, utilice un jabón suave o detergente para limpiarlos. Después de limpiarlos con un paño suave húmedo, séquelos con un paño seco. No utilice una solución de limpieza ácido-alcalina fuerte para realizar la limpieza.
2. Si el columpio y tobogán infantil no se utiliza durante mucho tiempo, guárdelo en un lugar fresco y seco y cúbralo con una tela o una manta limpia.

ADVERTÊNCIA:

1. A instalação só é permitida a adultos, manter as crianças afastadas.
2. Para ser usado sob a supervisão direta de um adulto.
3. Verificar se todas as peças estão bem ligadas antes da utilização.
4. Verificar e manter regularmente os componentes principais (suspensórios, fechos, fixações, etc.), caso contrário o baloiço pode tombar ou provocar uma queda.
5. A área de instalação deve ser tão ampla quanto possível, plana e evitar a humidade.
6. Manter afastado do fogo!

MANUTENÇÃO E CUIDADOS

1. Por favor, limpe as manchas de superfície do produto com um pano seco. Se necessário, use sabão ou detergente suave para limpá-las. Após limpar com um pano úmido macio, seque com um pano seco. Não use soluções de limpeza ácidas ou alcalinas fortes.
2. Se não for utilizado por um longo período, por favor, coloque-o em um local fresco e seco e cubra-o com um pano limpo ou cobertor.

AVVERTENZE:

1. Consentito solo agli adulti di installare, e tenere lontani I bambini.
2. Viene utilizzato sotto la diretta supervisione di un adulto.
3. Controllare che tutte le parti siano ben collegate prima dell'uso.
4. Controllare e mantenere regolarmente i componenti principali (strutture di sospensione, elementi di fissaggio, fissaggi, ecc.), altrimenti l'oscillazione potrebbe causare il ribaltamento o una caduta.
5. La zona per installazione deve essere il più ampia possibile, piatta ed evitare l'umidità.
6. Tenere lontano dal fuoco.

MANUTENZIONE:

1. Si prega di pulire le macchie superficiali del prodotto con un panno asciutto. Se necessario, utilizzare sapone o detergente morbido per pulirle. Dopo le aver pulito con un panno morbido e umido, pulire con un panno asciutto. Non utilizzare un forte detergente alcalino o acido.
2. Se non viene utilizzato per lungo tempo, conservarlo in un luogo fresco e asciutto, e coprirlo con un pezzo di pulito tessuto o con una coperta.

A x 3

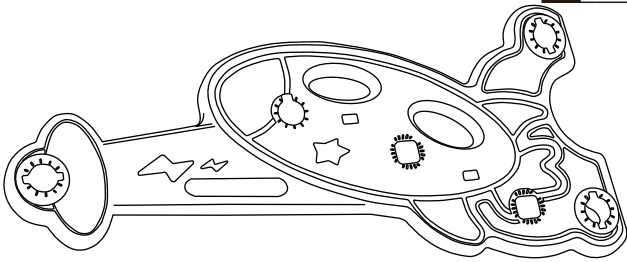

B x 2

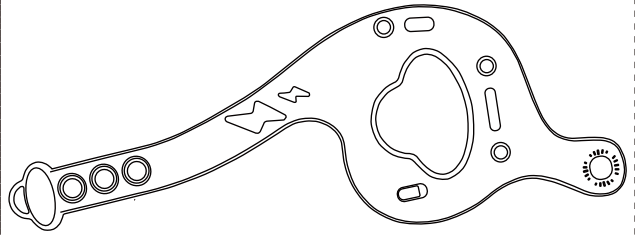

C x 2

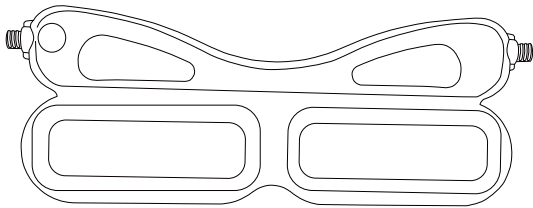

D x 1

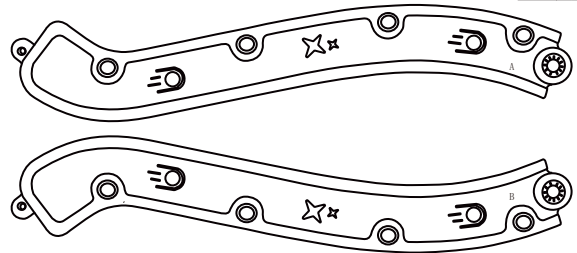

E x 1

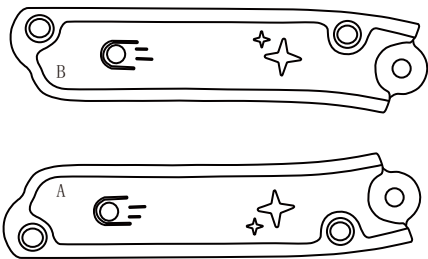

F x 1

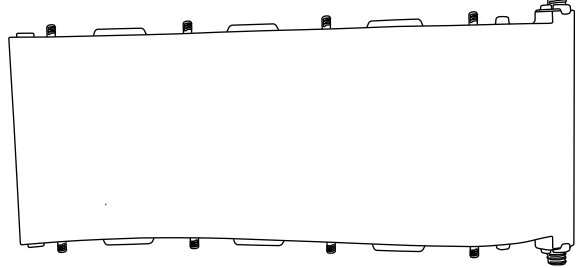

G x 1

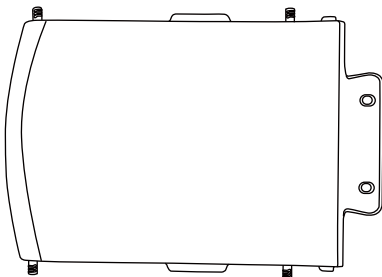

H x 1

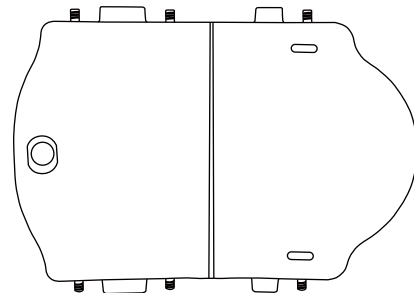

I x 1

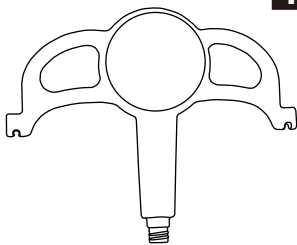

J x 1

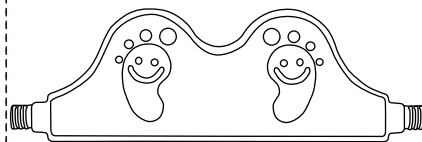

K x 2

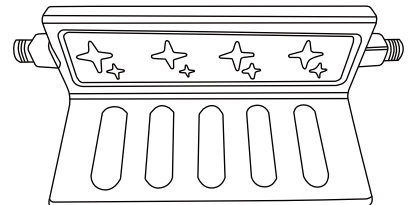



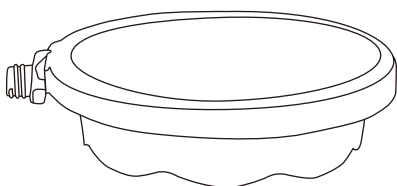



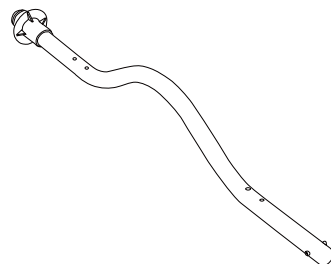

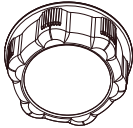

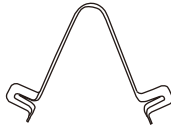
M x 1

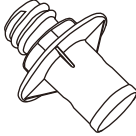

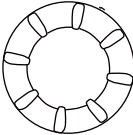
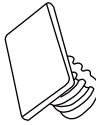
N x 1

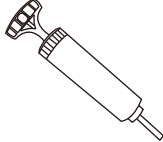

	O x 7 +1(spare)		P x 4 +1(spare)		Q x 1 +1(spare)
	R x 1 +1(spare)		S x 1 +1(spare)		T x 20 +1(spare)
	U x 9 +1(spare)		V x 2 +1(spare)		W x 1
	X x 1		Y x 2		

T X 2	V X 2
	

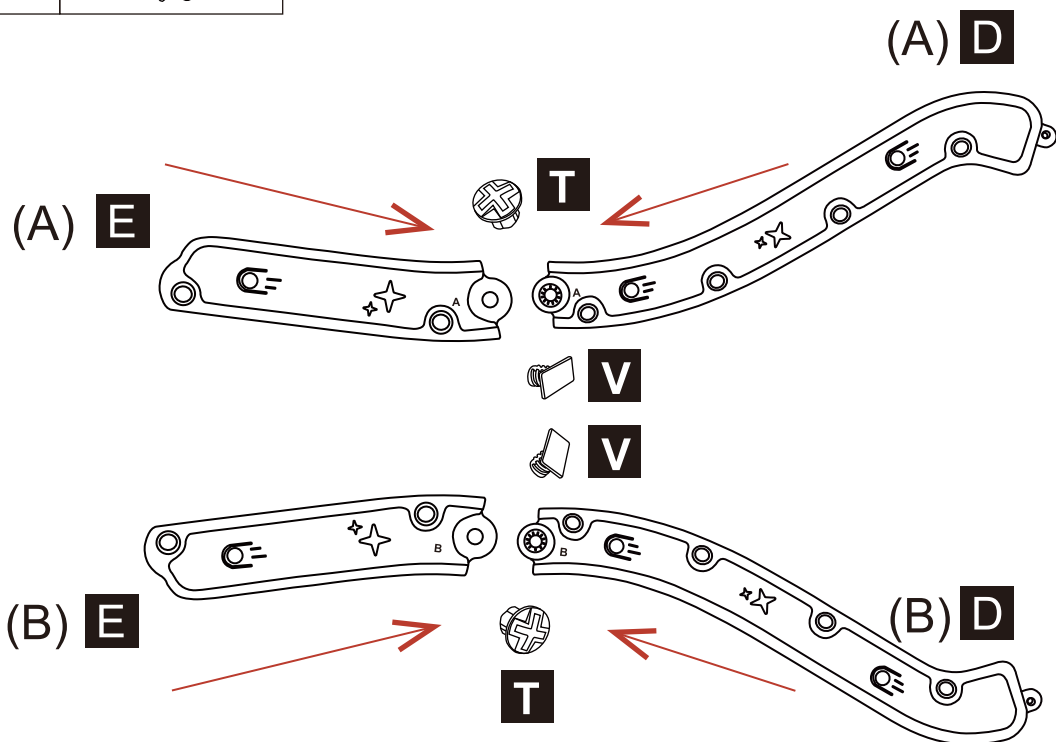

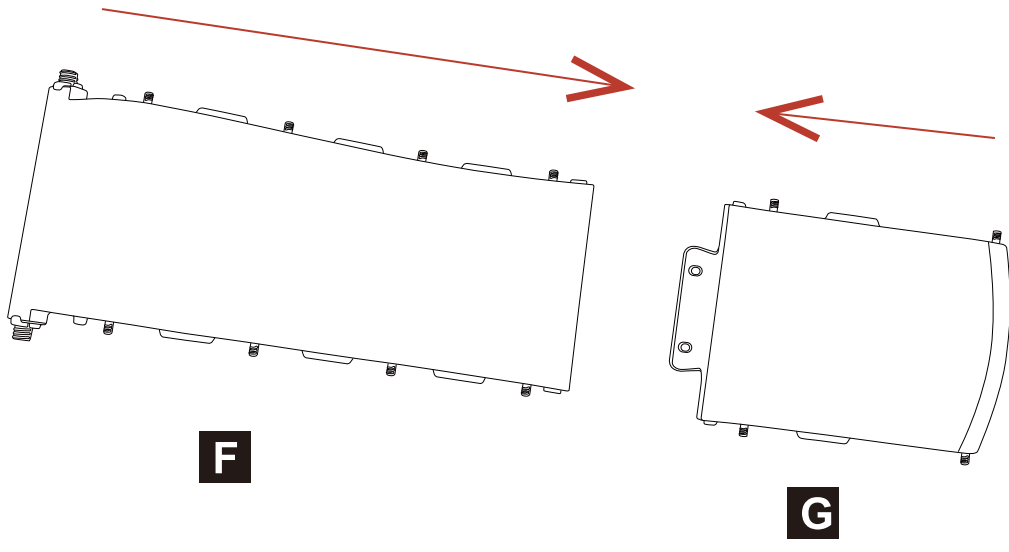

T X12

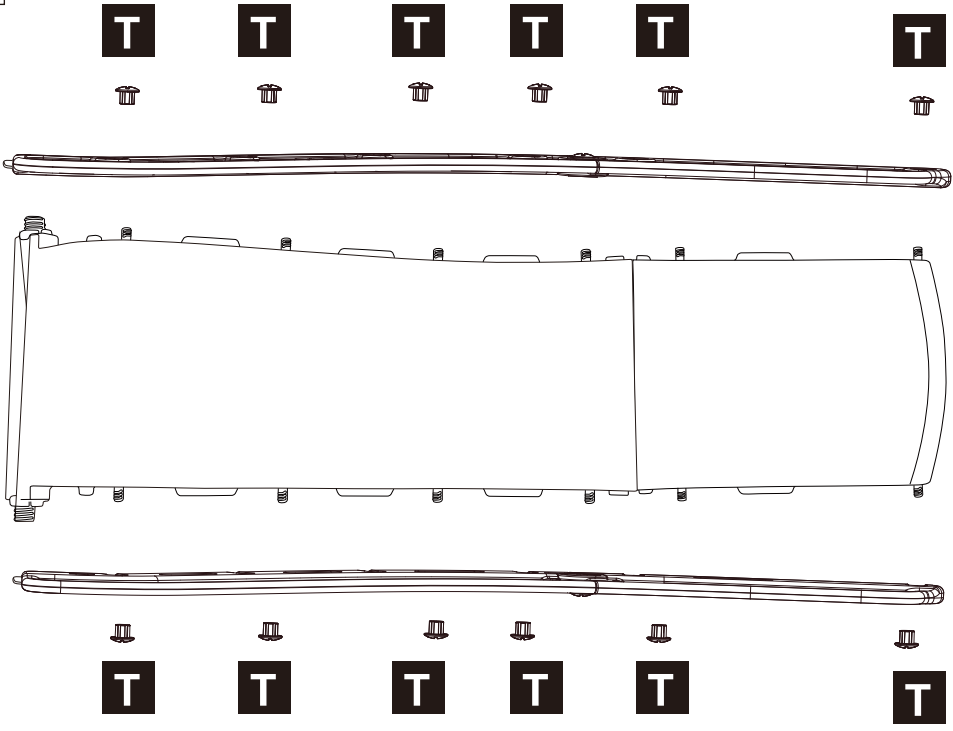

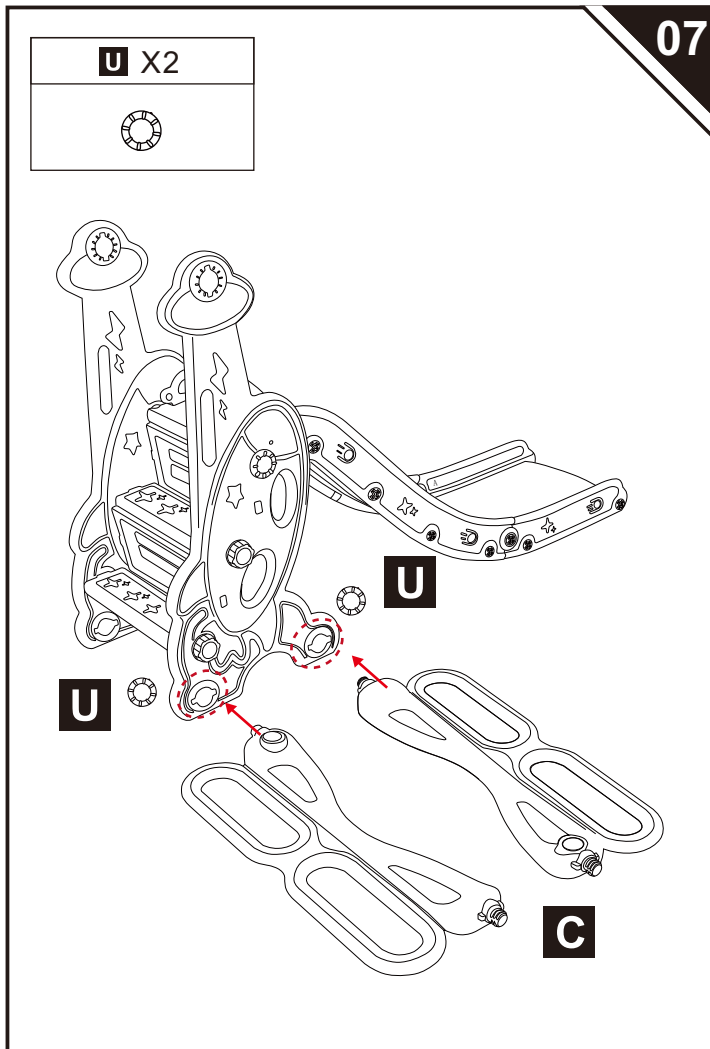
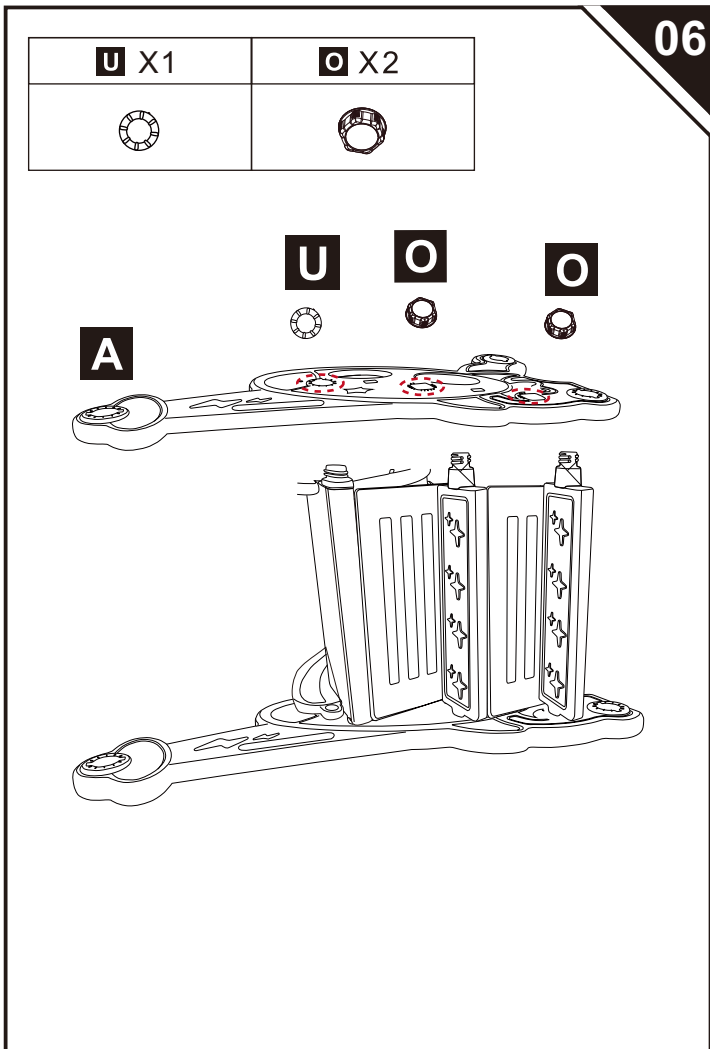
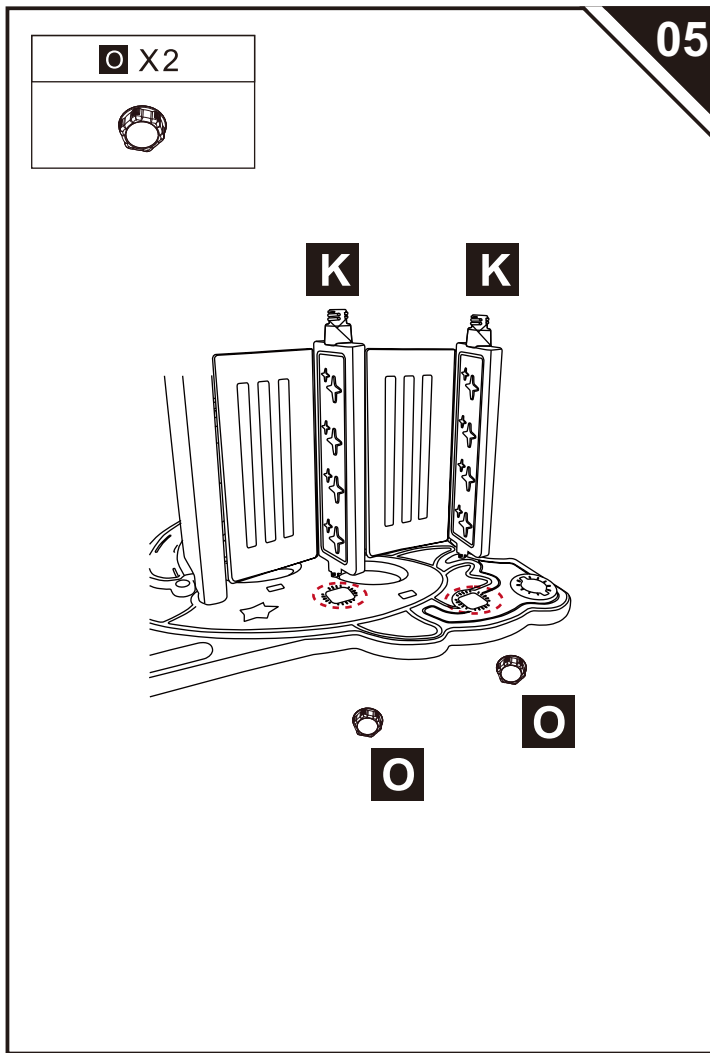
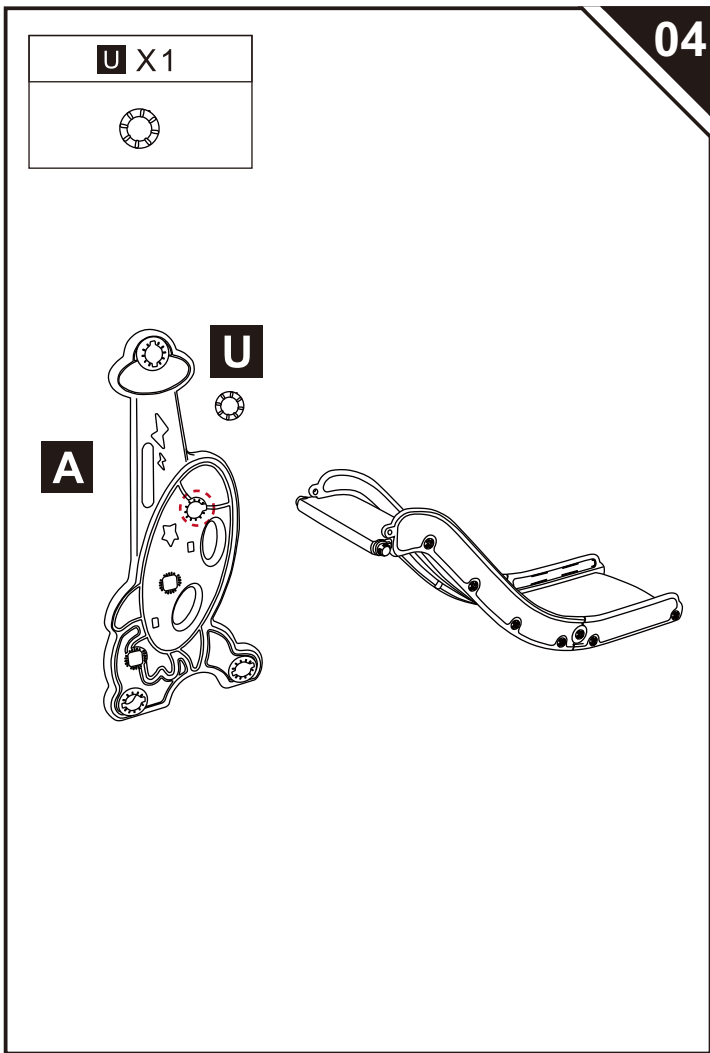

08

O X1

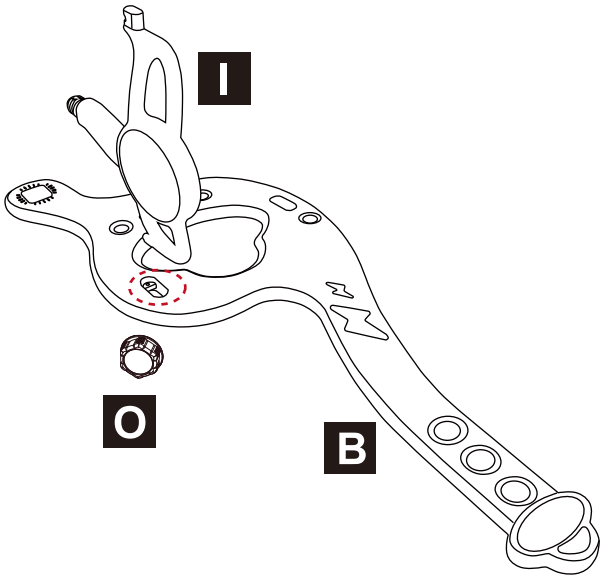

09

T X3

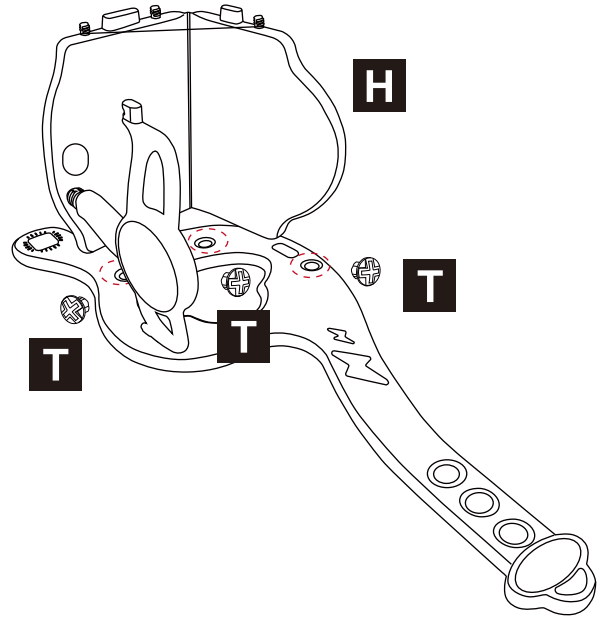

10

O X1

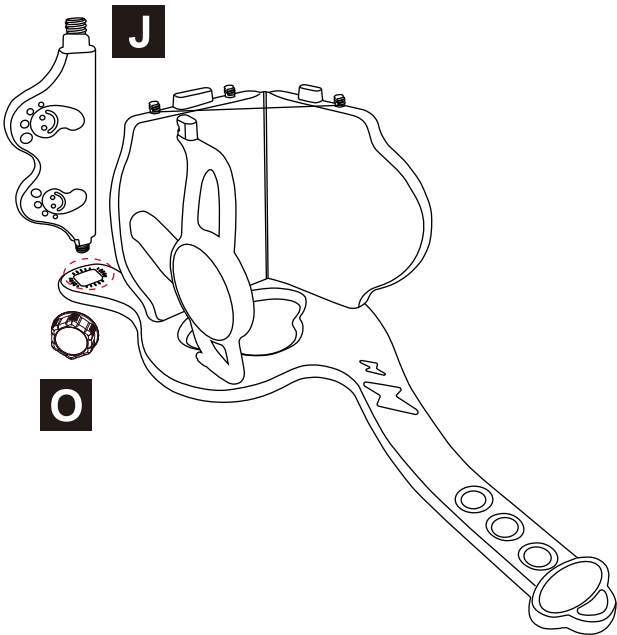



11

T X3

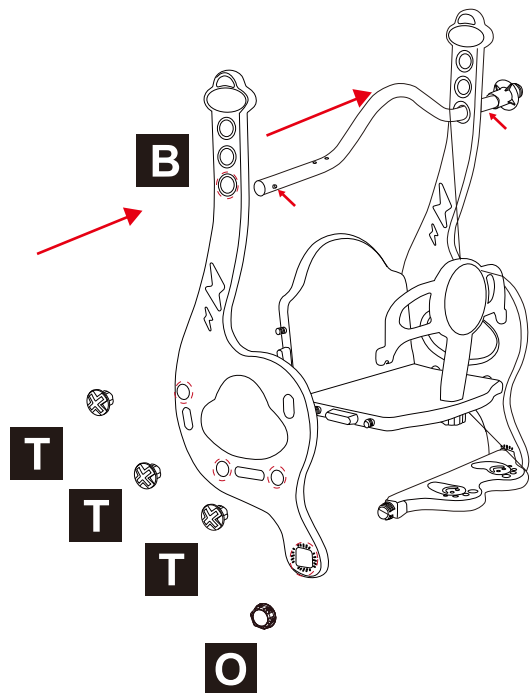

O X1



U X5	Y X2
	

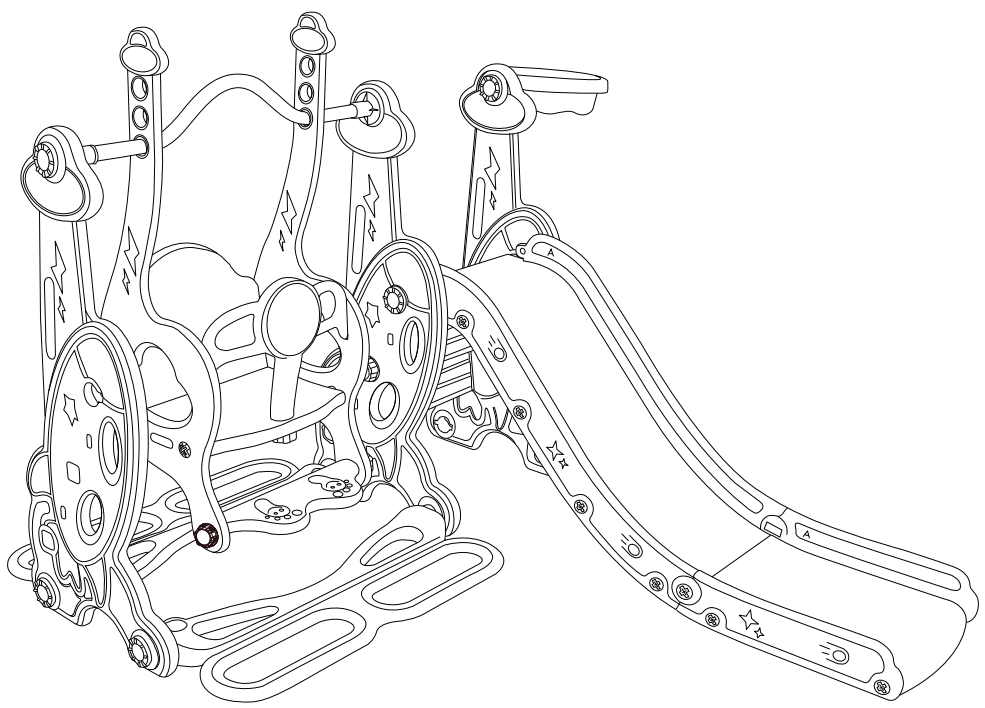
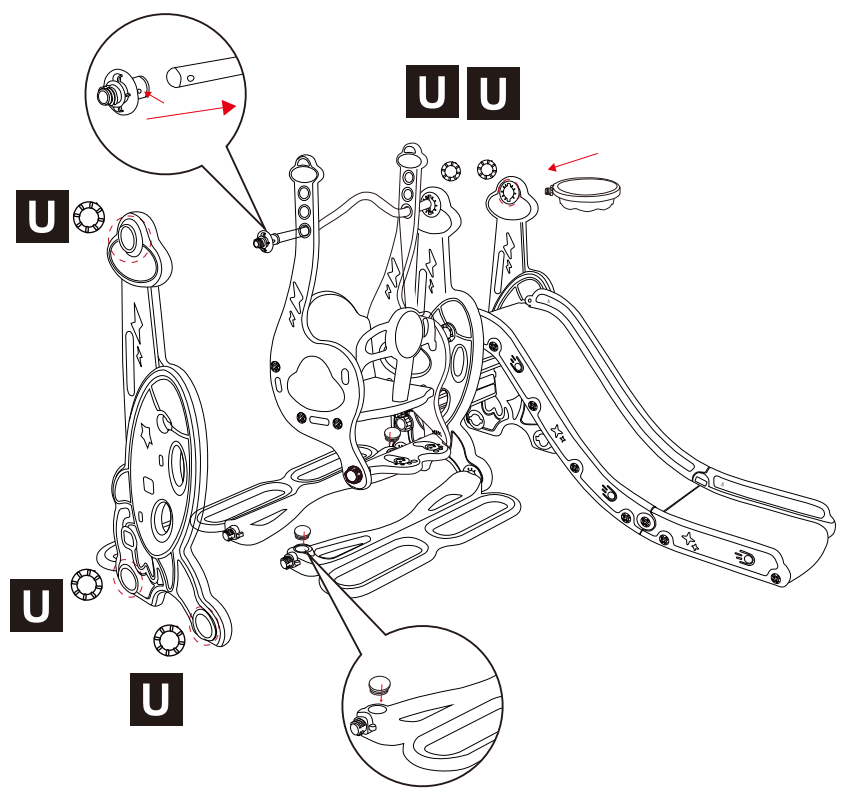

UK

If you have any questions, please contact our customer care centre.

Our contact details are below:



0044-800-240-4004



enquiries@mhstar.co.uk

IMPORTER ADDRESS:

MH STAR UK LTD

Unit 27, Perivale Park,

Horsenden lane South

Perivale, UB6 7RH

MADE IN CHINA

ES

Si tiene alguna pregunta, comuníquese con nuestro Centro de Atención al Cliente.

Nuestros datos de contacto son los siguientes:



0034-931294512



atencioncliente@aosom.es

Importador/Fabricante/REP:

Spanish Aosom, S.L.

C/ Roc Gros, nº 15. 08550, Els Hostalets de Balenyà, Spain.

B66295775

atencioncliente@aosom.es

TEL: 931294512

HECHO EN CHINA

FR

Si vous avez la moindre question, veuillez contacter notre centre d'assistance à la clientèle.

Nos coordonnées sont les suivantes:



0033-1-84166106



aosom@mhfrance.fr

Importé par/Fabricant/REP:

MH France

2, rue Maurice Hartmann

92130 Issy-les-Moulineaux

France

Fabriqué en Chine

PT

Se tiver alguma dúvida, por favor contacte o nosso Centro de Atendimento ao Cliente.

Os nossos dados de contacto são os seguintes:



0034-931294512



info@aosom.pt.

IMPORTADOR:

SPANISH AOSOM, S.L

C.ROC GROS N.15, 08550. ELS HOSTALETES DE BALENYÀ

TEL: 931294512 (SEG-SEX DAS 7:30H ÀS 16:30H)

INFO@AOSOM.PT

WWW.AOSOM.PT

DE

Wenn Sie Fragen haben, wenden Sie sich bitte an unser Kundendienstzentrum.

Unsere Kontaktdaten stehen unten:



0049-0(40)-88307530



service@aosom.de

Importeur/Hersteller/REP:

MH Handel GmbH

Wendenstraße 309

D-20537 Hamburg

Germany

IN CHINA HERGESTELLT

IT

In caso di dubbio, si prega di contattare il nostro centro assistenza clienti.

I nostri dettagli di contatto sono di seguito:



0039-0249471447



clienti@aosom.it

IMPORTATO DA/Produttore/REP:

AOSOM Italy srl

Centro Direzionale Milanofiori

Strada 1 Palazzo F1

20057 Assago (MI)

P.I.: 08567220960

FATTO IN CINA

