

# PawHut

IN241100185V01\_GL

**D00-204V00**



**9**  
STEPS

  
0.5 HR

**EN\_IMPORTANT, RETAIN FOR FUTURE REFERENCE: READ CAREFULLY.**

**FR\_IMPORTANT: A LIRE ATTENTIVEMENT ET À CONSERVER POUR CONSULTATION ULTÉRIEURE.**

**ES\_IMPORTANTE, LEA Y GUARDE PARA FUTURAS REFERENCIAS.**

**PT\_IMPORTANTE, RETER PARA REFERÊNCIA FUTURA: LEIA ATENTAMENTE.**

**DE\_WICHTIG! SORGFÄLTIG LESEN UND FÜR SPÄTER NACHSCHLAGEN AUFBEWAHREN.**

**IT\_IMPORTANTE! CONSERVARE IL PRESENTE MANUALE PER FUTURO RIFERIMENTO E LEGGERLO ATTENTAMENTE.**

**WARNING:Keep Away From Fire**

- 1.Please read this instruction carefully before use and keep it properly for future reference. If you do not follow this instruction, the safety of pets may be affected.
- 2.Do not leave the caregiver while the product is in use.
- 3.Do not use accessories not provided by the manufacturer.
- 4.Any load attached to the handle will affect the stability of the pet stroller.
- 5.Ensure that all the locking devices are assembled before using the pet stroller.
- 6.Pets must use restraints when using.
- 7.Do not use the pet stroller in rough areas, near stoves and other dangerous areas.
- 8.Avoid use or storage in damp, cold or high temperature environment and keep away from fire or strong heat source.
- 9.Do not use it to put dangerous animals which are aggressive and destructive.

**Maintenance and Care**

Please check and maintain the pet stroller frequently. The cloth cover cannot be dipped and washed. When the cloth cover is cleaned, please use a brush and other cleaning instruments to clean the dirt.

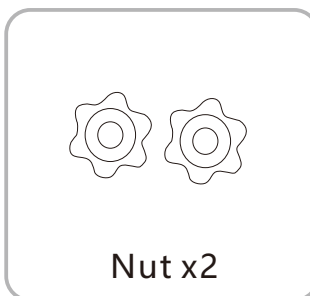
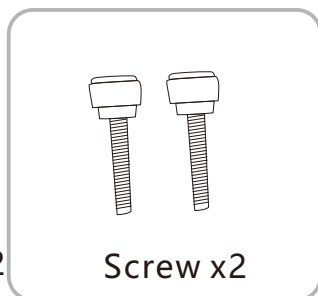
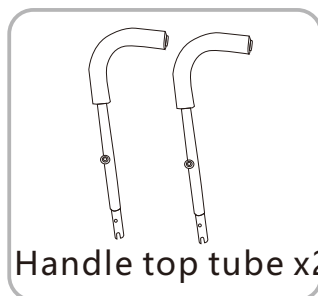
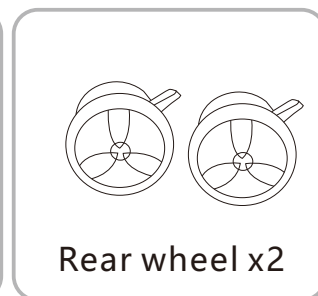
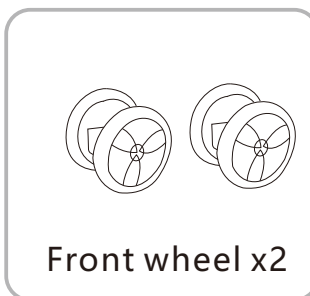
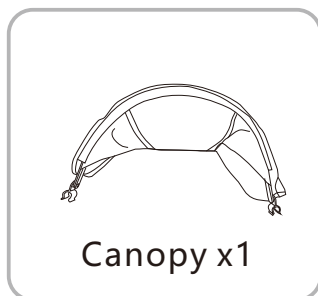
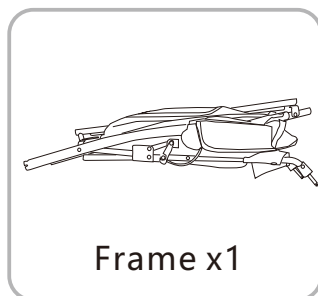
**Parts**

## Directions for use

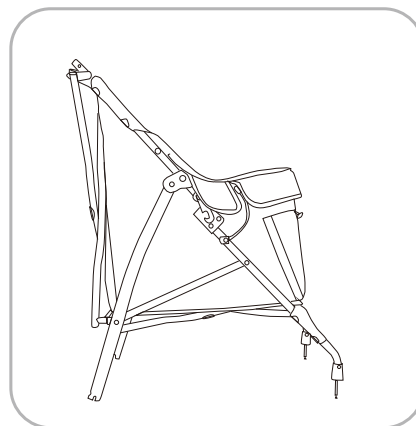
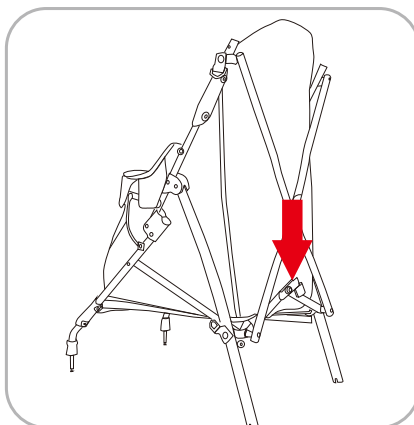
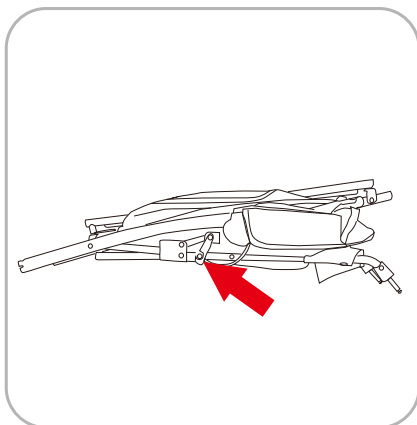

### 1. Unfolding frame

Release the hook, hold the handlebar with both hands and pull it upward and backward, press the locking mechanism by foot, confirm that the locking mechanism is reset.

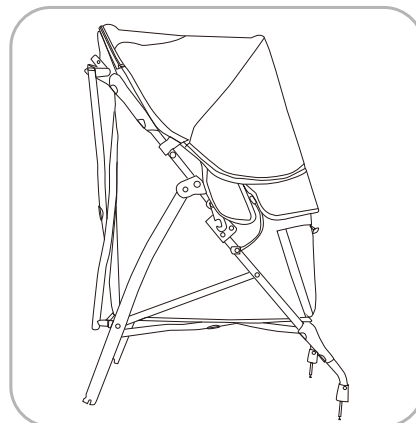
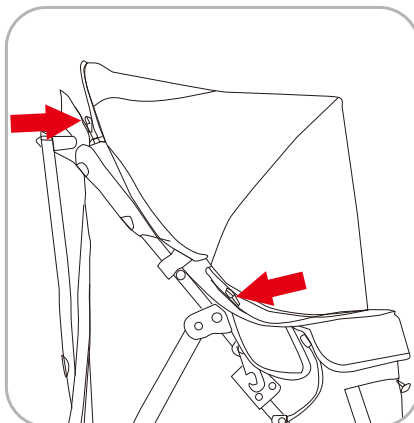
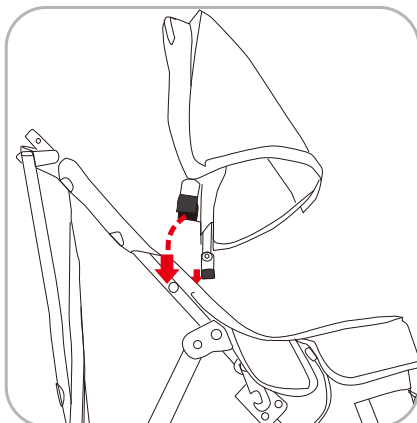

### 2. Install the canopy :

Clasp the clips of the canopy onto the tube, the clips should be fixed above the limiting column. And then zip up the zipper

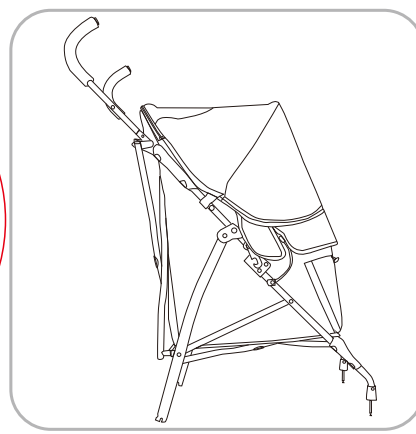
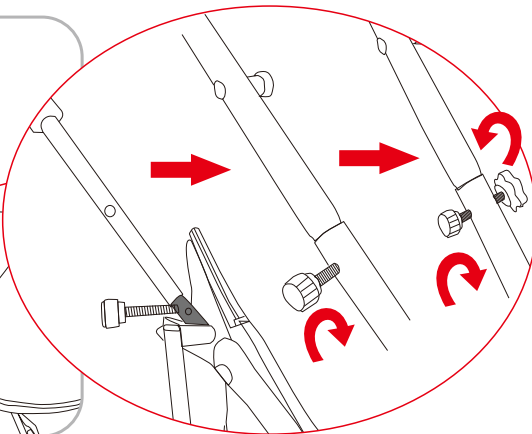
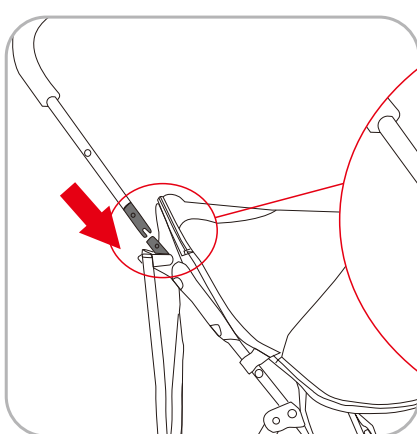

### 3. Install the handle top tube

Align the handlebar top tube with the handlebar bottom tube, insert it, install the screw and tighten the nut. Otherwise, the handlebar upper tube can be removed.

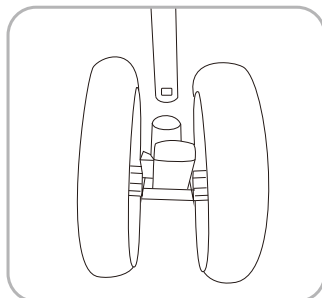
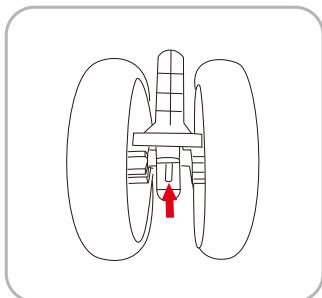
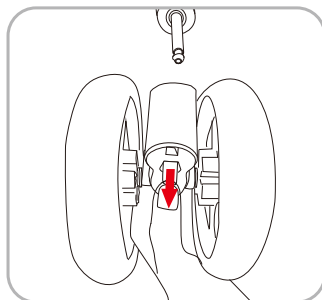
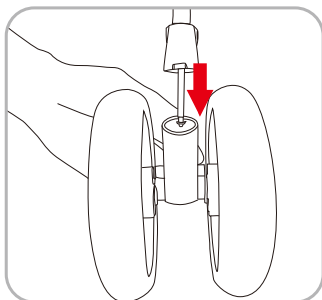

**4. Install and take-down of the front wheel**

Install and take-down of front wheel group: insert the front wheel group into the cover core of front foot tube, when the barb of cover core of front wheel spring out, the installation is ok. if you need to takedown the front wheel, just hold the barb and pull out the wheels, then the front wheel group will be taken down.

**5. Install and take down of rear wheel**

Insert the rear wheel group into the back foot tube, when the spring piece come out and lock is OK .Press down the spring piece and pull out the wheels , the rear wheel could be take down.

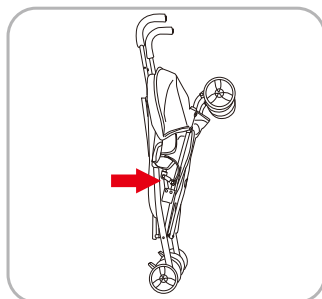
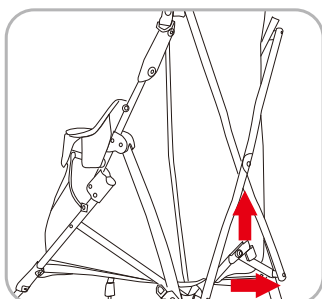

**6. Fold the frame**

In the braking state take out the bottom plate, hook the , locking mechanism outward and upward by foot, hold the handle bar forward and inward to close up. The frame is folded ,then hang the hook.

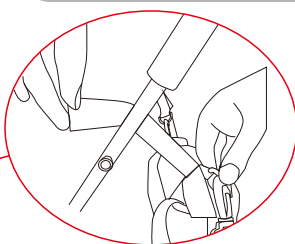
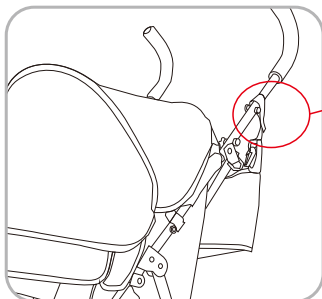

**7. Install the mummy bag**

Fix the Nylon buckle on both sides of the mummy bag above the limit column on the handlebar upper tube.



**8. Braking:**

Press down the rear wheel brake levers on both sides.

**Driving:**

Hook up the rear wheel brake levers on both sides.

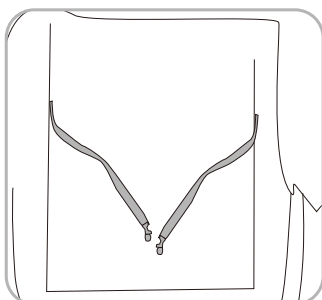

**9. For pet safety belts.**

**AVERTISSEMENT : À Garder à l'Écart Du Feu**

1. Prière de lire attentivement ces instructions avant l'utilisation et de les conserver pour s'y référer ultérieurement. Le non-respect de ces instructions peut affecter la sécurité des animaux domestiques.
2. Le gardien ne doit pas s'absenter pendant l'utilisation de l'appareil.
3. Ne pas utiliser d'accessoires non fournis par le fabricant.
4. La stabilité de la poussette est affectée par toute charge fixée à la poignée.
5. S'assurer que tous les dispositifs de verrouillage sont assemblés avant d'utiliser la poussette pour animaux.
6. Les animaux domestiques doivent être attachés lors de l'utilisation.
7. Ne pas utiliser la poussette dans des endroits rugueux, à proximité de foyers ou d'autres endroits dangereux.
8. Éviter d'utiliser ou de ranger la poussette dans un environnement humide, froid ou à haute température et la tenir éloignée du feu ou d'une source de chaleur intense.
9. La poussette ne doit pas être utilisée pour transporter des animaux dangereux, agressifs et nuisibles.

**Maintenance et Entretien**

La poussette doit être vérifiée et entretenue fréquemment. La housse en tissu ne doit pas être trempée ni lavée. Lorsque la housse en tissu doit être nettoyée, prière d'utiliser une brosse et d'autres instruments de nettoyage pour enlever la saleté.

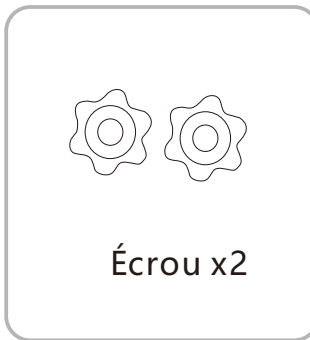
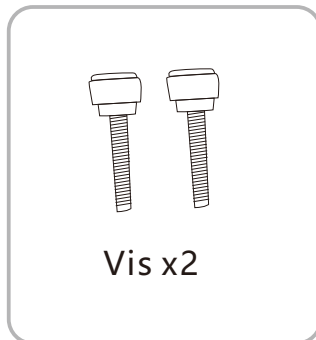
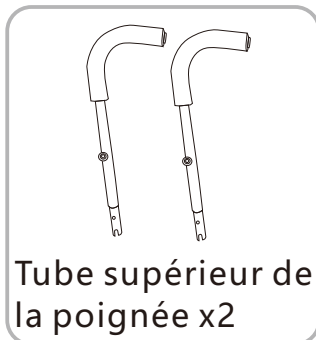
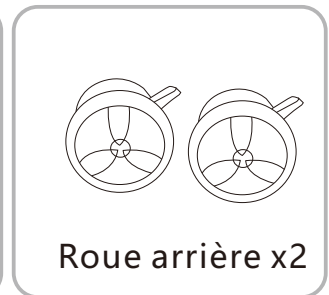
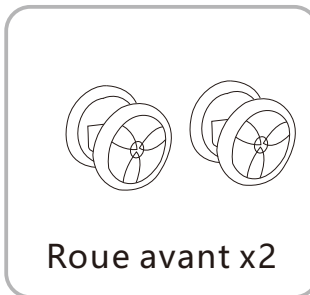
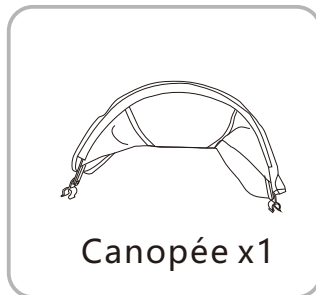
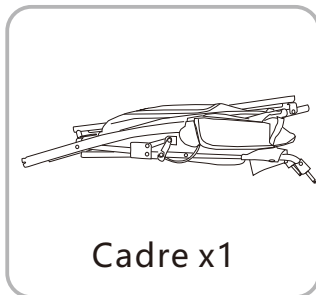
**Pièces**

## Mode d'emploi

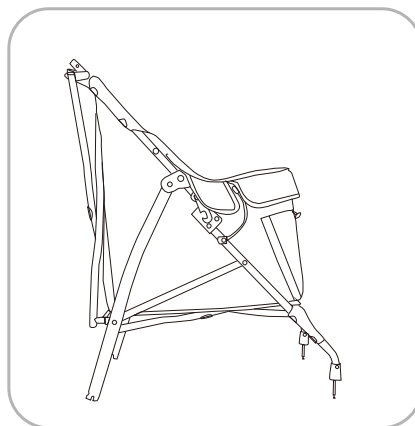
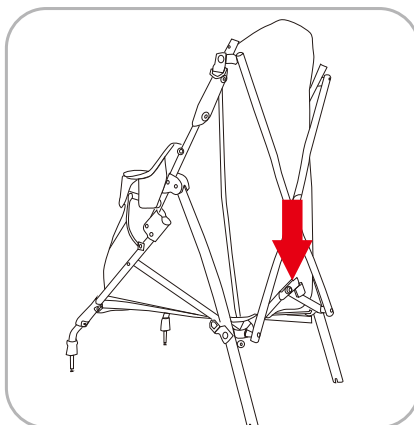
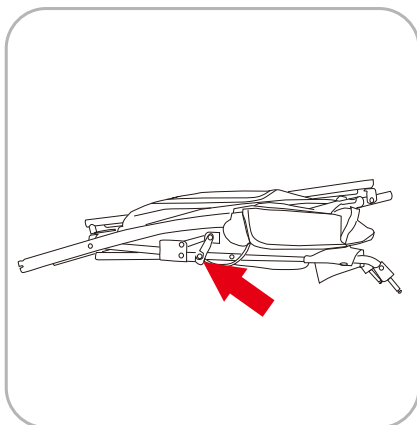

## 1. déplier le cadre

Relâcher le crochet, tenir le guidon à deux mains et le tirer vers le haut et vers l'arrière, appuyer sur le mécanisme de verrouillage avec le pied, confirmer que le mécanisme de verrouillage est réinitialisé.

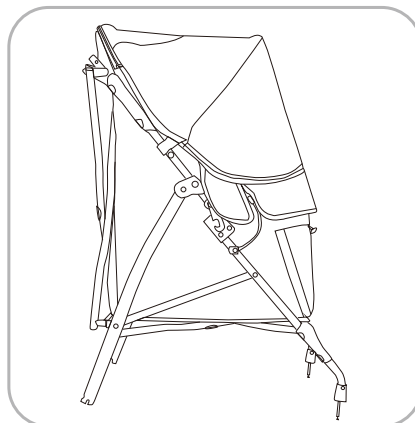
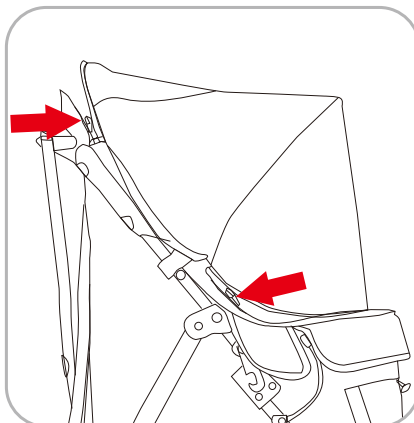
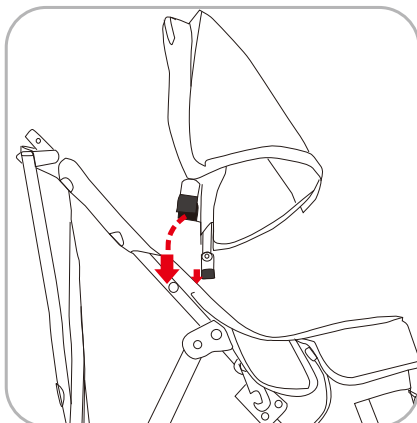

## 2. Installer la capote :

Fixez les clips de la voile sur le tube, les clips doivent être fixés au-dessus de la colonne de limitation. Puis refermez la fermeture à glissière

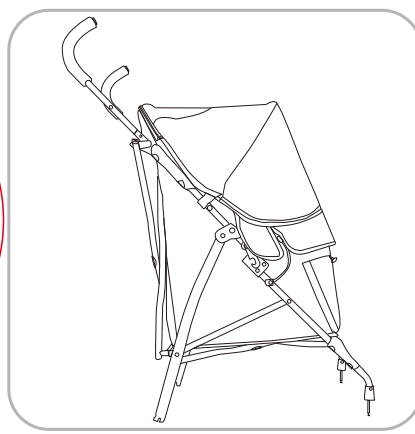
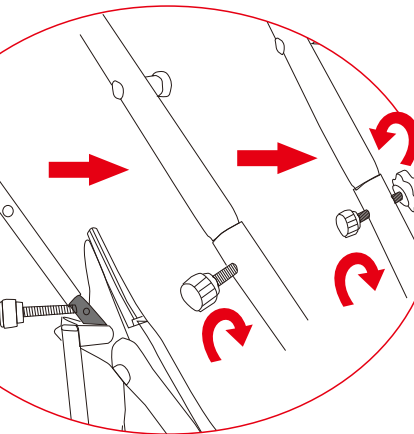
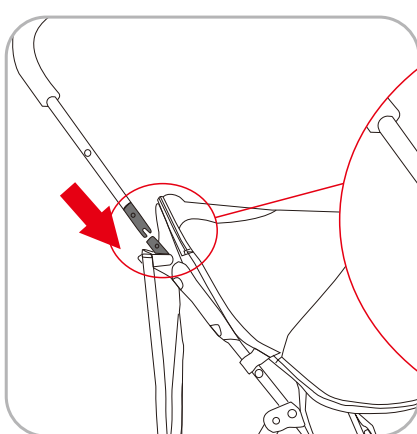

## 3. Installation du tube supérieur du guidon

Alignez le tube supérieur du guidon avec le tube inférieur du guidon, insérez-le, installez la vis et serrez l'écrou. Sinon, le tube supérieur du guidon peut être retiré.

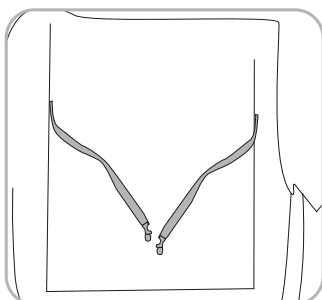
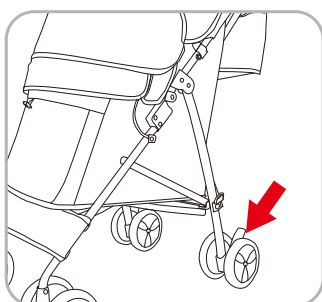
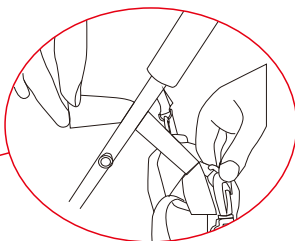
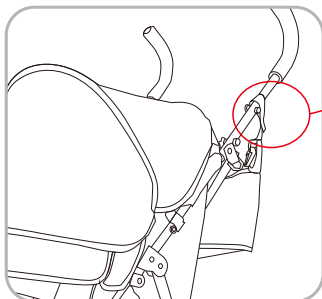
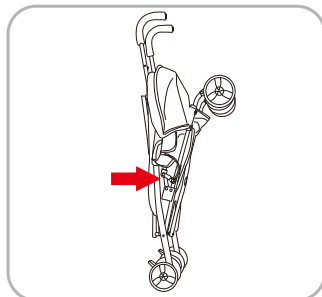
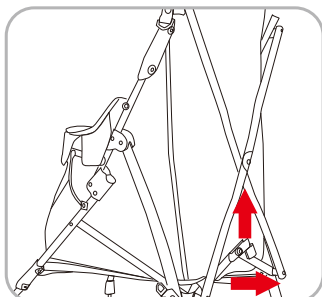
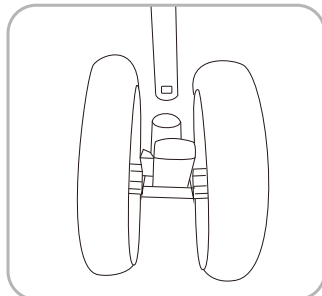
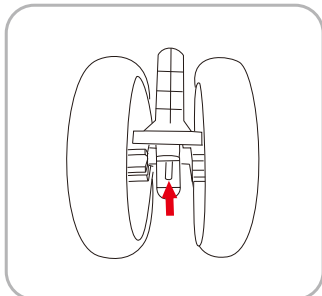
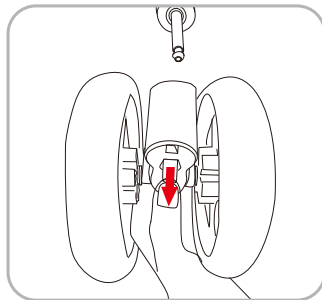
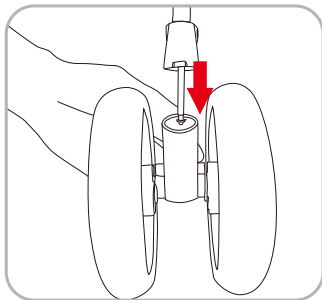

#### 4. installation et démontage de la roue avant

Installation et démontage du groupe de roues avant : insérer le groupe de roues avant dans le noyau de recouvrement du tube de pied avant, lorsque l'ardillon du noyau de recouvrement de la roue avant ressort, l'installation est correcte. Si vous devez démonter la roue avant, il suffit de tenir l'ardillon et de tirer sur les roues, puis le groupe de roues avant sera démonté.

#### 5. Installation et démontage de la roue arrière

Insérer le groupe de roues arrière dans le tube de pied arrière, lorsque la pièce de ressort sort et que le verrouillage est correct, appuyer sur la pièce de ressort et retirer les roues, la roue arrière peut être démontée.

#### 6. plier le cadre

En état de freinage, retirer la plaque inférieure, accrocher le mécanisme de verrouillage vers l'extérieur et vers le haut à l'aide du pied, tenir le guidon vers l'avant et vers l'intérieur pour le fermer. Le cadre est plié, puis accroché au crochet.

#### 7. installer le sac à dos

Fixer le Boucle nylon des deux côtés du sac de couchage au-dessus de la colonne de limite sur le tube supérieur du guidon.

#### 8. freinage :

Appuyer sur les leviers de frein de la roue arrière des deux côtés.

#### Conduite :

Accrocher les leviers de frein des roues arrière des deux côtés.

9. pour les ceintures de sécurité des animaux de compagnie.

**ADVERTENCIA: Mantener alejado del fuego**

1. Por favor, lea atentamente estas instrucciones antes de usar el aparato y guárdelas para futuras consultas. Si no sigue estas instrucciones, la seguridad de las mascotas puede verse afectada.
2. No deje al cuidador mientras el producto está en uso.
3. No utilice accesorios no proporcionados por el fabricante.
4. Cualquier carga fijada al mango afectará la estabilidad del cochecito para mascotas.
5. Asegúrese de que todos los dispositivos de bloqueo estén montados antes de usar la silla de paseo para mascotas.
6. Los animales domésticos deben ir sujetos cuando se esté usando el producto.
7. No use el cochecito para mascotas en zonas abrumadas, cerca de estufas y otras zonas peligrosas.
8. Evite el uso o el almacenamiento en ambientes húmedos, fríos o con altas temperaturas y manténgalo alejado del fuego o de fuentes de calor fuertes.
9. No lo utilice para colocar animales peligrosos que sean agresivos y destructivos.

**Mantenimiento y Cuidado**

Por favor, compruebe y mantenga el cochecito para mascotas con frecuencia. La funda de tela no se puede sumergir ni lavar. Cuando se limpie la cubierta de tela, por favor, utilice un cepillo y otros instrumentos de limpieza para limpiar la suciedad.

**Piezas**

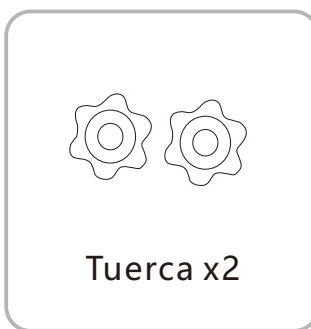
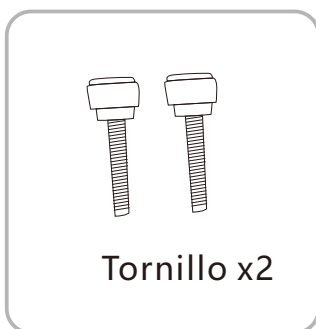
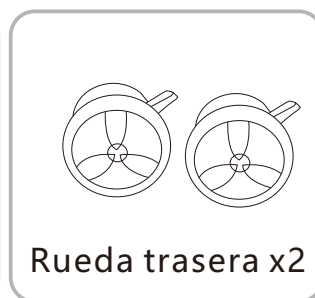
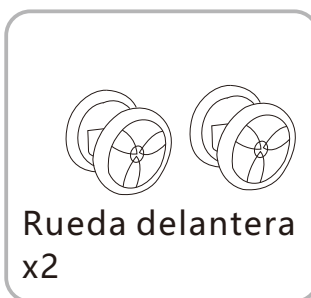
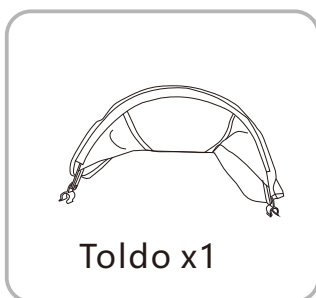
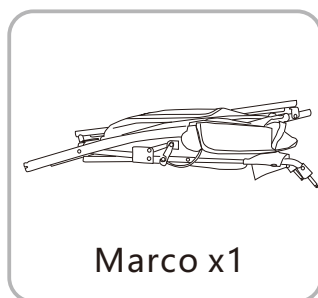

## Instrucciones de uso

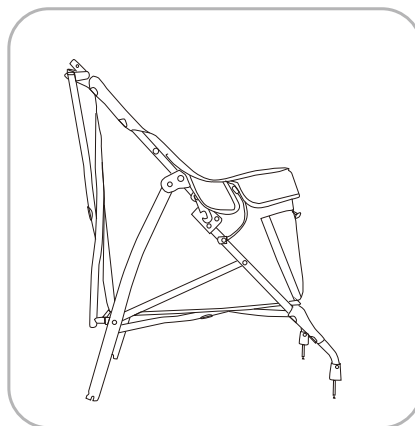
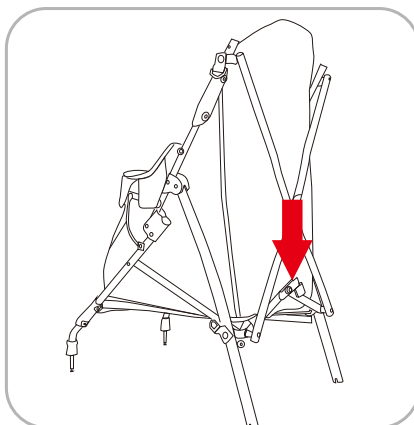
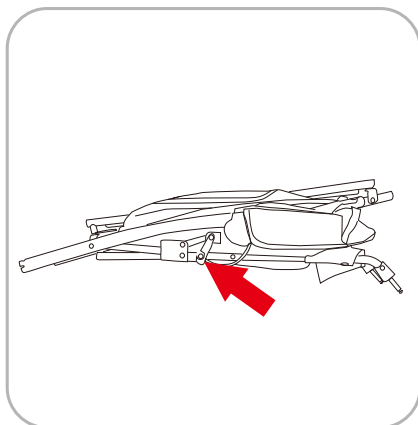

## 1. Desplegar el cuadro

Suelte el gancho, sujete el manillar con ambas manos y tire de él hacia arriba y hacia atrás, presione el mecanismo de bloqueo con el pie, confirme que el mecanismo de bloqueo está restablecido.

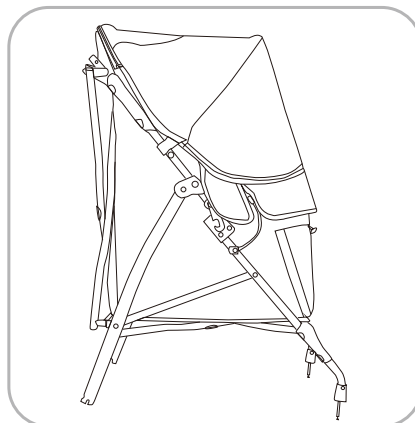
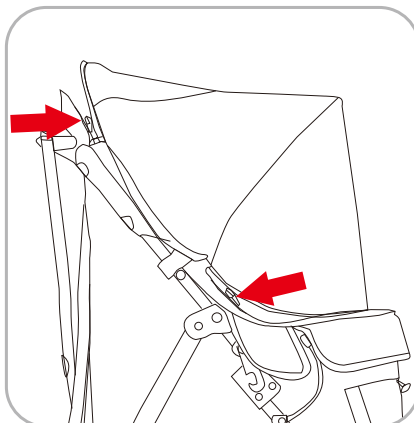
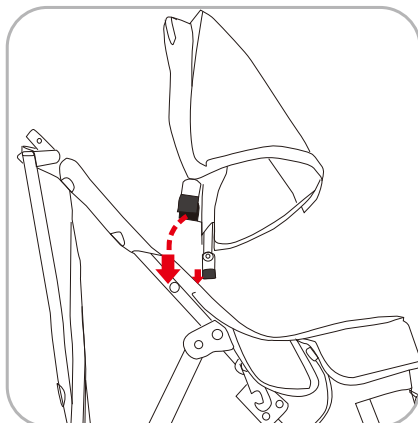

## 2. Instale la capota :

Enganche los clips de la capota en el tubo, los clips deben fijarse por encima de la columna limitadora. Y luego cierra la cremallera

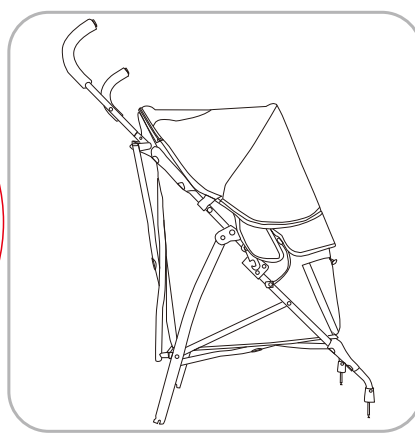
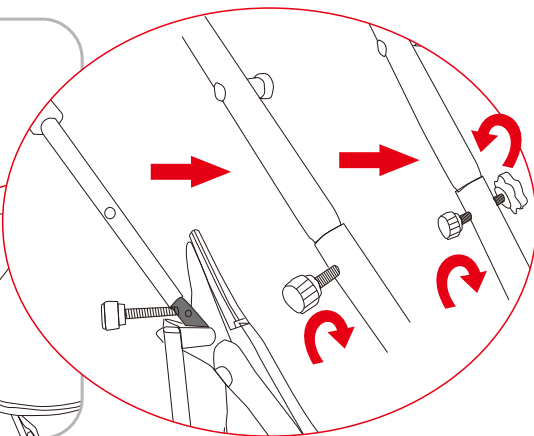
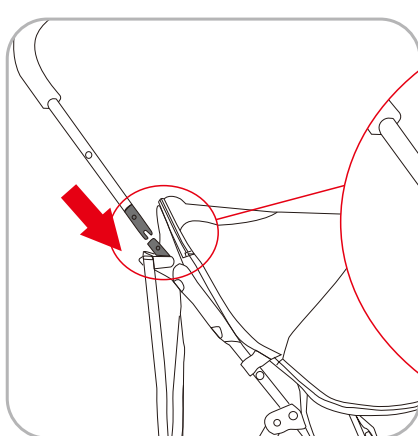

## 3. Instale el tubo superior del manillar

Alinee el tubo superior del manillar con el tubo inferior del manillar, insértelo, instale el tornillo y apriete la tuerca. De lo contrario, se puede desmontar el tubo superior del manillar.

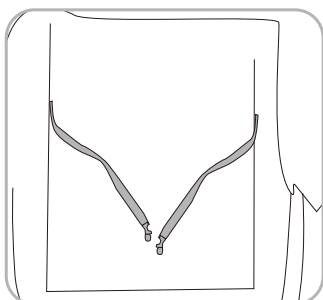
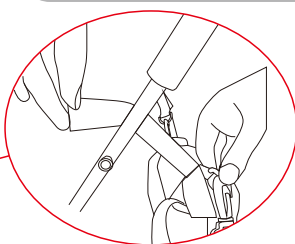
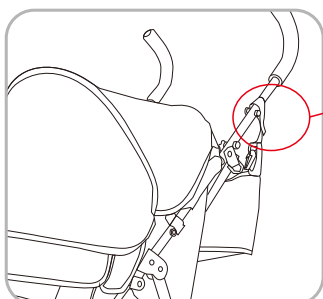
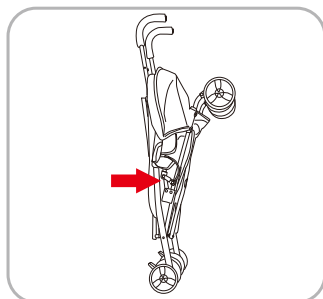
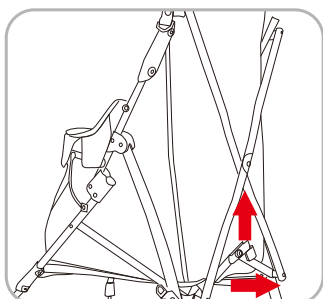
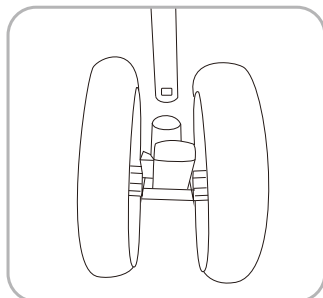
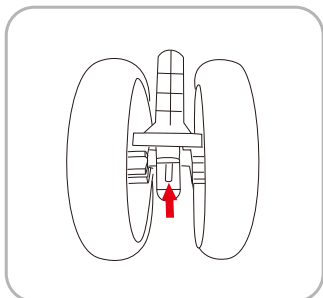
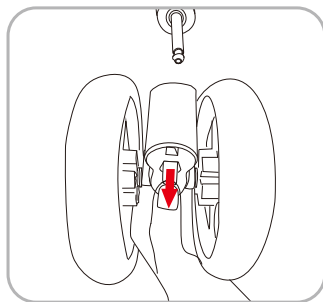
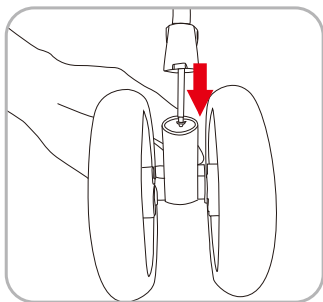

**4. Instalación y desmontaje de la rueda delantera**

Instalación y desmontaje del grupo de ruedas delanteras: inserte el grupo de ruedas delanteras en el núcleo de la cubierta del tubo del pie delantero, cuando la lengüeta del núcleo de la cubierta de la rueda delantera salga, la instalación está bien. si necesita desmontar la rueda delantera, simplemente sujete la lengüeta y tire de las ruedas, entonces el grupo de ruedas delanteras se desmontará.

**5. Instalación y desmontaje de la rueda trasera**

Inserte el grupo de ruedas traseras en el tubo del pie trasero, cuando la pieza del muelle salga y se bloquee, presione hacia abajo la pieza del muelle y saque las ruedas, la rueda trasera podrá desmontarse.

**6. Pliegue el cuadro**

En estado de frenado, saque la placa inferior, enganche el mecanismo de bloqueo hacia fuera y hacia arriba con el pie, sujete el manillar hacia delante y hacia dentro para cerrarlo. El cuadro se pliega y se cuelga del gancho.

**7. Instale la bolsa de la momia**

Fije el Hebillas de nailon en ambos lados de la bolsa de la momia por encima de la columna de límite en el tubo superior del manillar.

**8. Frenado:**

Presione hacia abajo las palancas de freno de la rueda trasera en ambos lados.

**9. Conducción:**

Enganche las palancas de freno de la rueda trasera en ambos lados.

**9. Cinturones de seguridad para mascotas.**

**AVISO: Mantenha-se Longe do Fogo**

1. Por favor leia esta instrução cuidadosamente antes de usar e guarde-a devidamente para referência futura. Se não seguir estas instruções, a segurança dos animais de estimação pode ser afetada.
2. Não deixe o prestador de cuidados enquanto o produto estiver em uso.
3. Não utilize acessórios não fornecidos pelo fabricante.
4. Qualquer carga presa à pega afetará a estabilidade do carrinho do animal.
5. Certifique-se de que todos os dispositivos de bloqueio estão montados antes de usar o carrinho de passeio para animais domésticos.
6. Animais de estimação devem usar trelas.
7. Não use o carrinho de passeio em áreas ásperas, perto de fogões e outras áreas perigosas.
8. Evitar o uso ou armazenamento em ambientes húmidos, frios ou de alta temperatura e manter longe de fogo ou fonte de calor forte.
9. Não o utilize para colocar animais perigosos que sejam agressivos e destrutivos.

**Manutenção e Cuidados**

Por favor, verifique e mantenha o carrinho de passeio frequentemente. A cobertura do pano não pode ser mergulhada e lavada. Quando a cobertura do pano for limpa, por favor use uma escova e outros instrumentos de limpeza para limpar a sujidade.

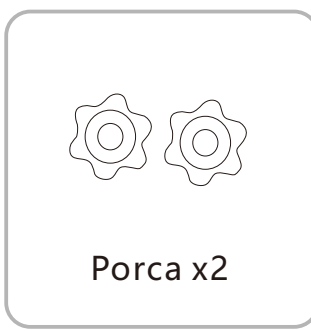
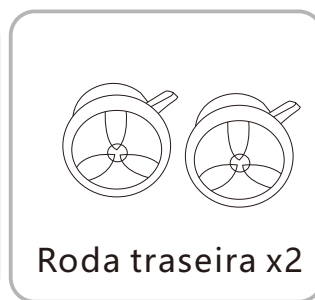
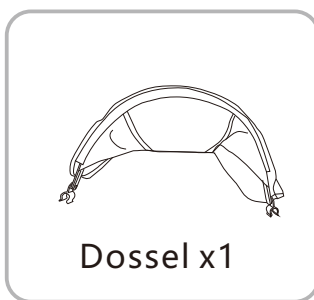
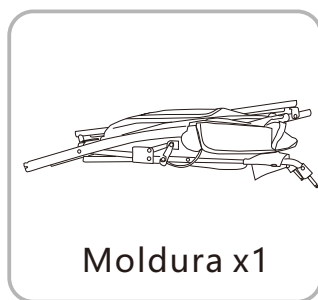
**Partes**

## Modo de utilização

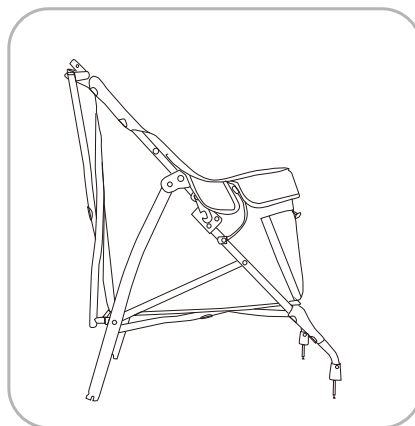
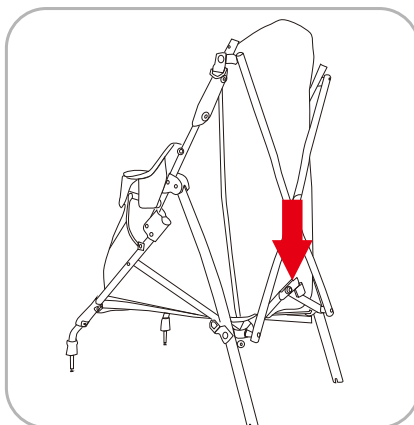
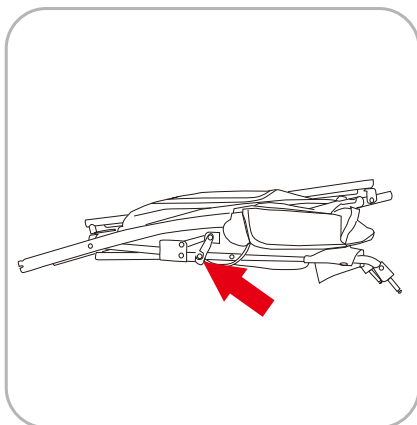

### 1. desdobrar o quadro

Solte o gancho, segure o guidador com as duas mãos e puxe-o para cima e para trás, prima o mecanismo de bloqueio com o pé, confirme que o mecanismo de bloqueio é reposto.

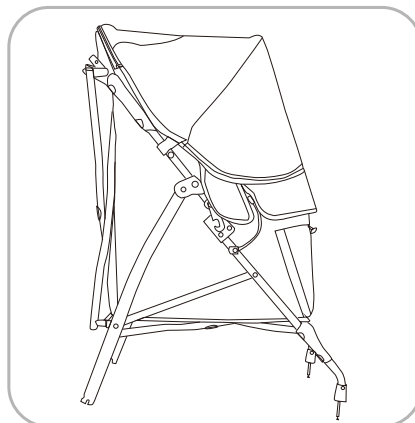
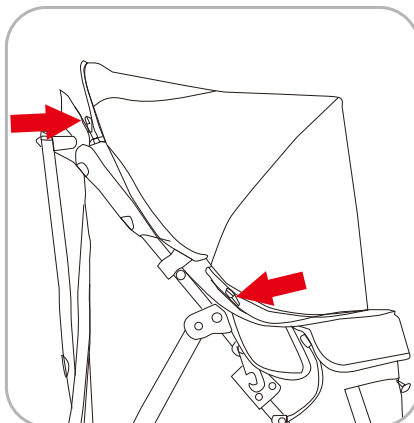
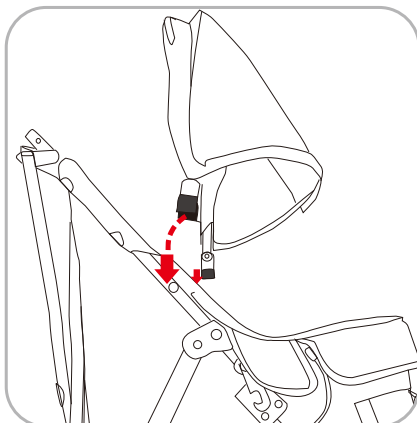

### 2. Instalar a capota:

Prenda os cliques da capota no tubo, os cliques devem ser fixados acima da coluna de limitação. Depois, feche o fecho de correr

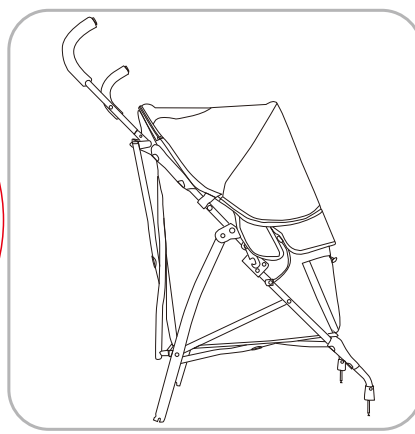
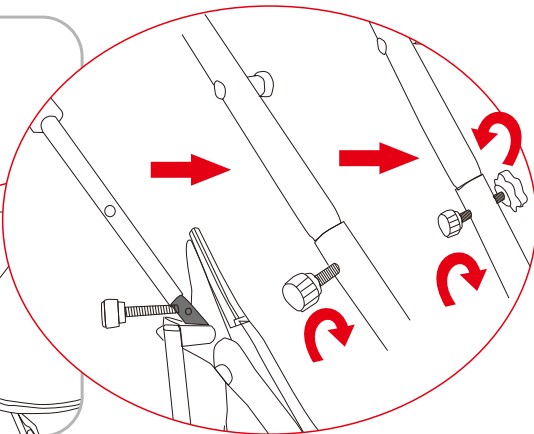
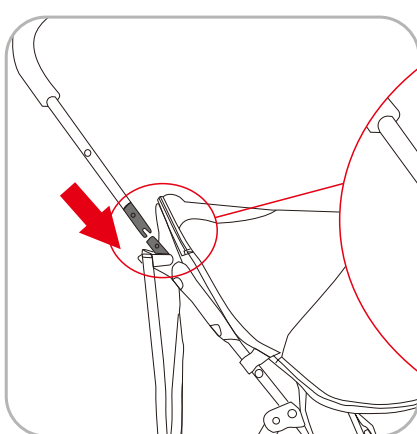

### 3. instalar o tubo superior do guidador

Alinhe o tubo superior do guidador com o tubo inferior do guidador, insira-o, instale o parafuso e aperte a porca. Caso contrário, o tubo superior do guidador pode ser retirado.

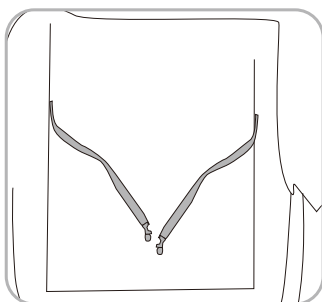
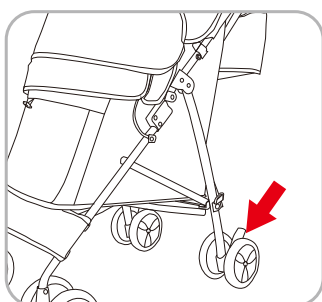
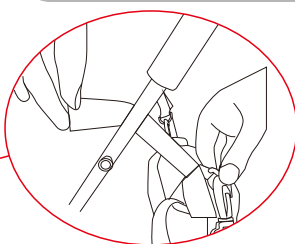
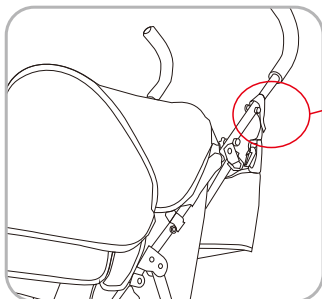
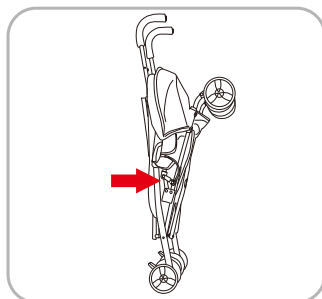
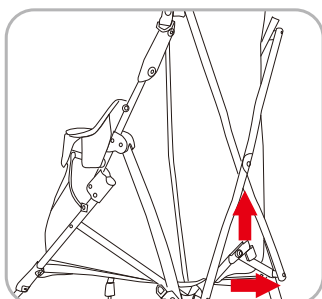
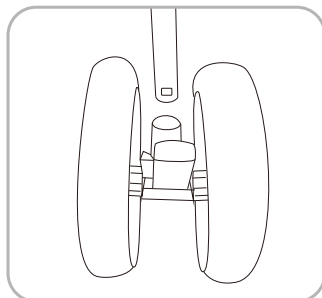
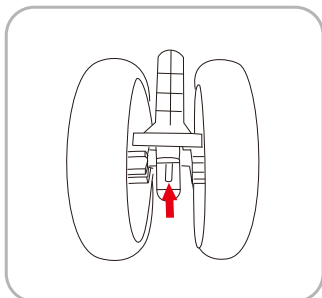
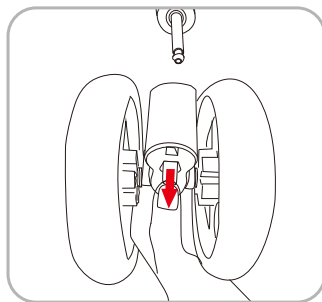
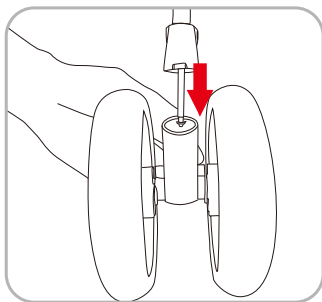

#### 4. instalar e desmontar a roda dianteira

Instalar e desmontar o grupo da roda dianteira: inserir o grupo da roda dianteira no núcleo da cobertura do tubo do pé dianteiro, quando a farpa do núcleo da cobertura da roda dianteira saltar para fora, a instalação está correta. Se for necessário desmontar a roda dianteira, basta segurar a farpa e puxar as rodas para fora, depois o grupo da roda dianteira será desmontado.

#### 5. instalar e desmontar a roda traseira

Insira o grupo da roda traseira no tubo do pé traseiro, quando a peça da mola sair e o bloqueio estiver correto.

#### 6. dobrar o quadro

No estado de travagem, retirar a placa inferior, enganchar o mecanismo de bloqueio para fora e para cima com o pé, segurar o guidador para a frente e para dentro para fechar. A estrutura é dobrada e, em seguida, pendurada no gancho.

#### 7) Instalar o saco de transporte

Fixe o Fivela de nylon em ambos os lados do saco de transporte acima da coluna de limite no tubo superior do guidador.

#### 8. Travagem:

Pressione as alavancas dos travões das rodas traseiras de ambos os lados.

#### Condução:

Engatar as alavancas dos travões das rodas traseiras de ambos os lados.

#### 9. para cintos de segurança para animais de estimação.

**WARNUNG: Von Feuer fernhalten**

1. Bitte lesen Sie diese Anweisung vor der Verwendung sorgfältig durch und bewahren Sie sie zum späteren Nachschlagen auf. Wenn Sie diese Anweisung nicht befolgen, kann die Sicherheit von Haustieren beeinträchtigt werden.
2. Während der Verwendung des Produkts darf sich die Betreuungsperson nicht entfernen.
3. Verwenden Sie kein Zubehör, das nicht vom Hersteller bereitgestellt wird.
4. Jede an der Lenkstange befestigte Last beeinträchtigt die Stabilität des Hundebuggys.
5. Stellen Sie sicher, dass alle Verriegelungsvorrichtungen vor der Verwendung des Hundebuggys montiert sind.
6. Haustiere müssen bei der Verwendung angeschnallt sein.
7. Verwenden Sie den Hundebuggy nicht in rauen Gegenden, in der Nähe von Öfen oder anderen gefährlichen Bereichen.
8. Verwenden oder lagern Sie ihn nicht in feuchten, kalten oder heißen Umgebungen und halten Sie ihn von Feuer oder starken Wärmequellen fern.
9. Verwenden Sie ihn nicht für gefährliche Tiere, die aggressiv und zerstörerisch sind.

**Wartung und Pflege**

Bitte überprüfen und warten Sie den Hundebuggy regelmäßig. Das Verdeck kann nicht getaucht und gewaschen werden. Wenn Sie das Verdeck reinigen, verwenden Sie bitte eine Bürste und andere Reinigungsmittel, um den Schmutz zu entfernen.

**Teile**

## Gebrauchsanweisung

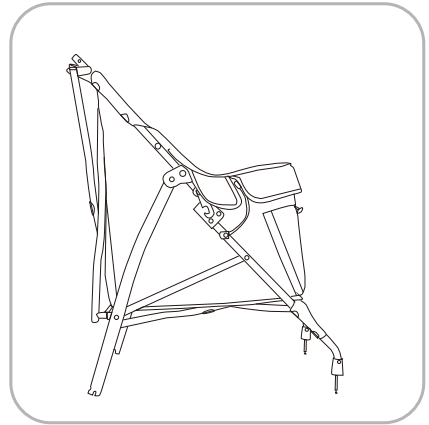
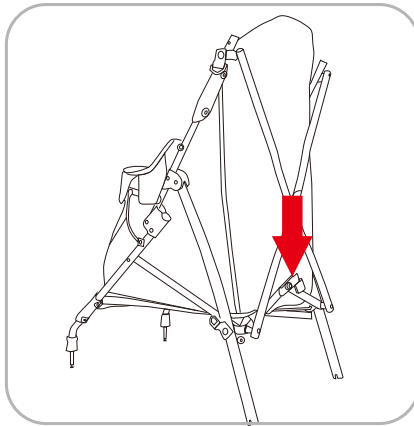
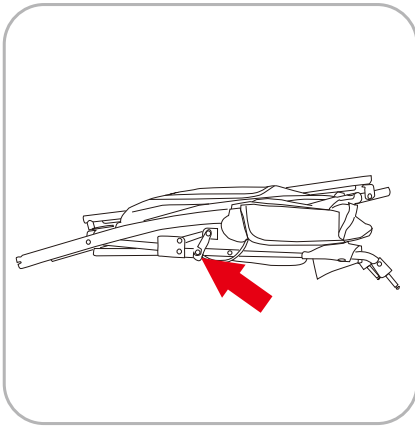

## 1. den Rahmen ausklappen

Lösen Sie den Haken, halten Sie den Lenker mit beiden Händen fest und ziehen Sie ihn nach oben und hinten, drücken Sie den Verriegelungsmechanismus mit dem Fuß, stellen Sie sicher, dass der Verriegelungsmechanismus zurückgesetzt ist.

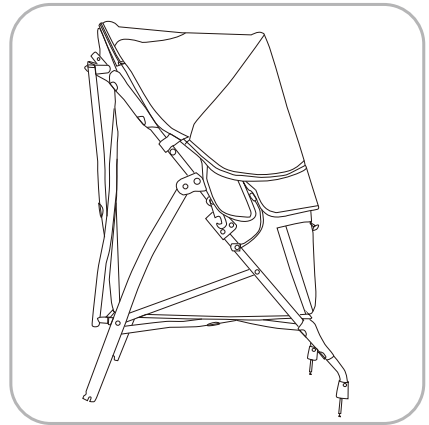
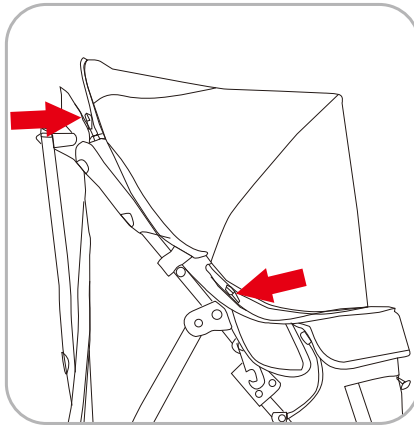
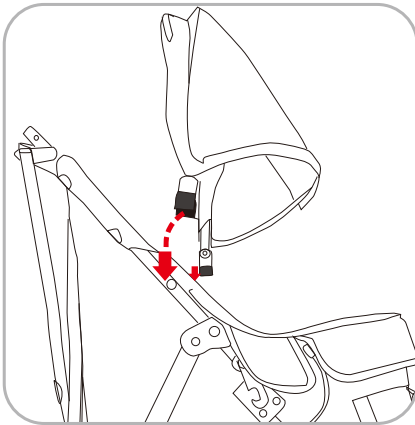

## 2. installieren Sie das Verdeck:

Schließen Sie die Clips der Kabinenhaube an das Rohr, die Clips sollten oberhalb der Begrenzungssäule befestigt sein. Und dann den Reißverschluss zuziehen

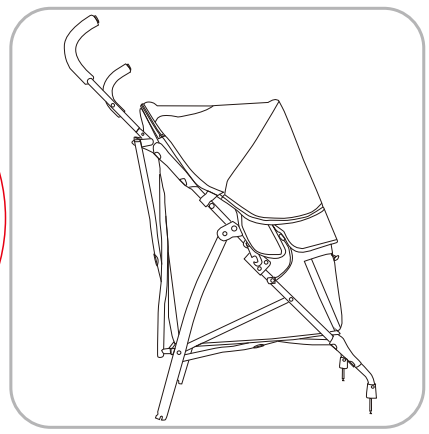
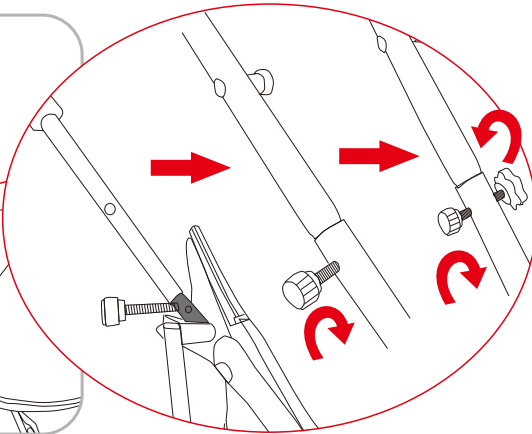
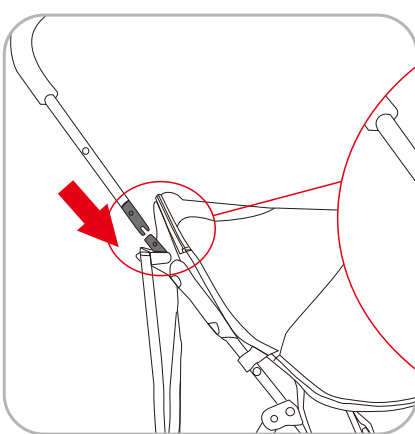

## 3. montieren Sie das Lenkeroberrohr

Richten Sie das Lenkeroberrohr mit dem Lenkerunterrohr aus, setzen Sie es ein, bringen Sie die Schraube an und ziehen Sie die Mutter fest. Andernfalls kann das Lenkeroberrohr entfernt werden.

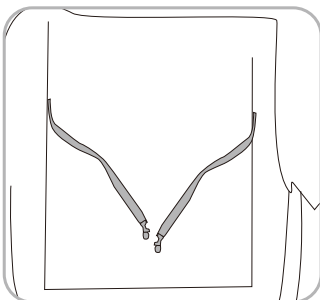
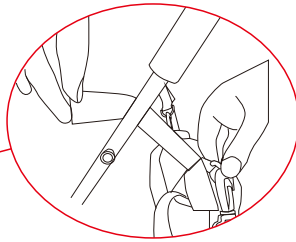
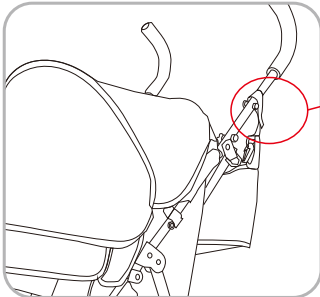
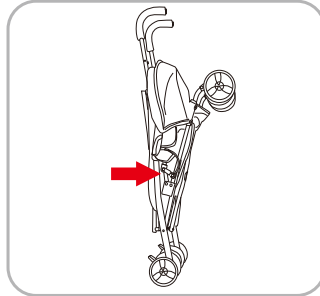
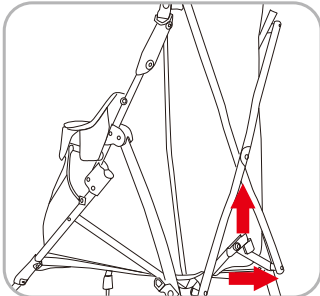
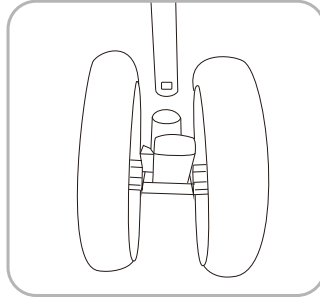
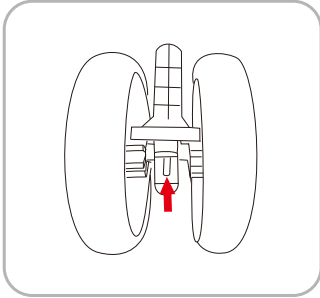
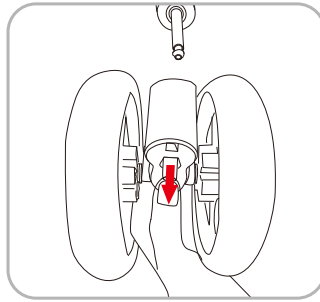
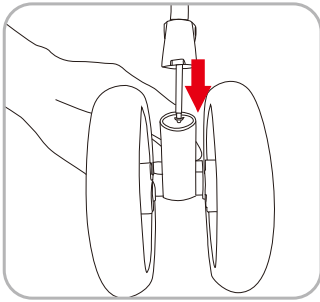

4. einbau und ausbau des vorderrads  
Montage und Demontage der Vorderradgruppe: Stecken Sie die Vorderradgruppe in den Abdeckkern des vorderen Fußrohrs, wenn der Widerhaken des Abdeckkerns des Vorderrads herauspringt, ist die Installation in Ordnung. Wenn Sie das Vorderrad abnehmen müssen, halten Sie einfach den Widerhaken und ziehen Sie die Räder heraus, dann wird die Vorderradgruppe abgenommen.

5. einbau und ausbau des hinterrads  
Setzen Sie die Hinterradgruppe in das hintere Fußrohr ein, wenn das Federteil herauskommt und die Verriegelung in Ordnung ist, drücken Sie das Federteil nach unten und ziehen Sie die Räder heraus, dann kann das Hinterrad abgenommen werden.

6. klappen Sie den Rahmen zusammen

Im gebremsten Zustand die Bodenplatte herausnehmen, den Verriegelungsmechanismus mit dem Fuß nach außen und nach oben einhaken, den Lenker nach vorne und nach innen halten, um ihn zu schließen. Der Rahmen ist gefaltet, dann hängen Sie den Haken.

7. montieren Sie den Mumienbeutel  
Befestigen Sie den Klettverschluss auf beiden Seiten der Mumientasche oberhalb der Begrenzungssäule am oberen Rohr des Lenkers.

8. bremsen:

Drücken Sie die Hinterradbremshelbel auf beiden Seiten herunter.

Fahren:

Hängen Sie die Hinterradbremshelbel auf beiden Seiten ein.

9. für Sicherheitsgurte für Haustiere.

**AVVERTENZA:** Tenere lontano dal fuoco

1. Si prega di leggere attentamente le presenti istruzioni prima dell'uso e di conservarle per future consultazioni. Se non si seguono queste istruzioni, la sicurezza degli animali domestici potrebbe essere compromessa.

2. Non lasciare andare la persona che assiste quando il prodotto è in uso.

3. Non utilizzare accessori non forniti dal produttore.

4. Qualsiasi carico attaccato alla maniglia influisce sulla stabilità del passeggino.

5. Assicurarsi che tutti i dispositivi di bloccaggio siano montati prima di utilizzare il passeggino.

6. Gli animali domestici devono essere trattiene durante l'uso.

7. Non utilizzare il passeggino in zone impervie, vicino a stufe o altre aree pericolose.

8. Evitare l'uso o lo stoccaggio in ambienti umidi, freddi o ad alta temperatura e tenerlo lontano dal fuoco o da fonti di calore forte.

9. Non utilizzarlo per animali pericolosi, aggressivi e distruttivi.

### Manutenzione e Cura

Controllare e mantenere frequentemente il passeggino per animali domestici. Il rivestimento in tessuto non può essere immerso in liquido e lavato. Quando si pulisce il rivestimento in tessuto, utilizzare una spazzola e altri strumenti di pulizia per pulire lo sporco.

### Parti di ricambio

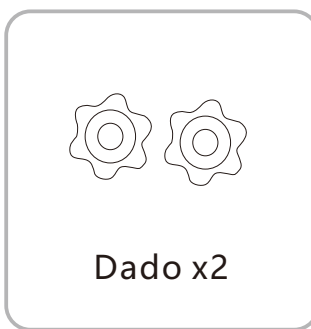
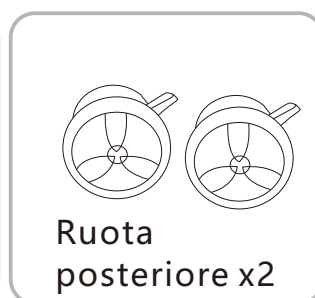
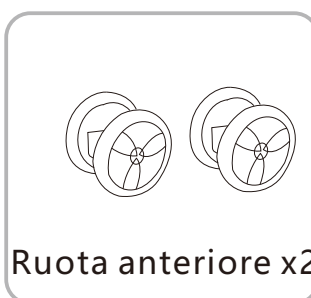
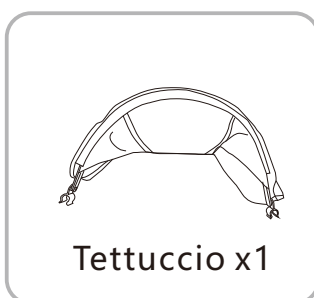
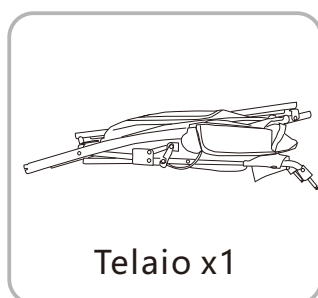

## Istruzioni per l'uso

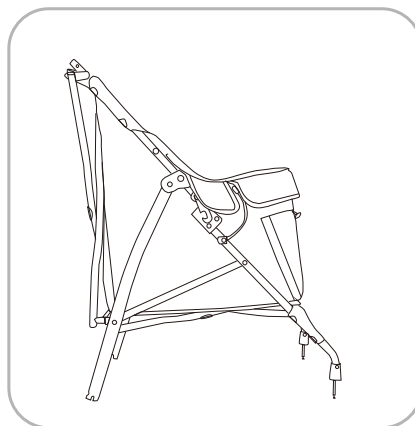
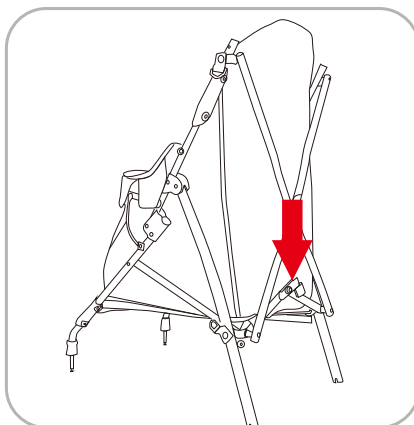
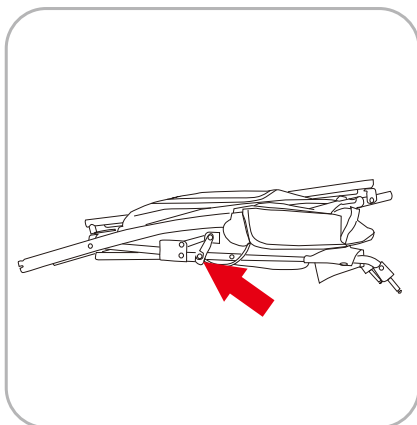

## 1. Dispiegare il telaio

Rilasciare il gancio, afferrare il manubrio con entrambe le mani e tirarlo verso l'alto e all'indietro, premere il meccanismo di bloccaggio con il piede, verificare che il meccanismo di bloccaggio sia ripristinato.

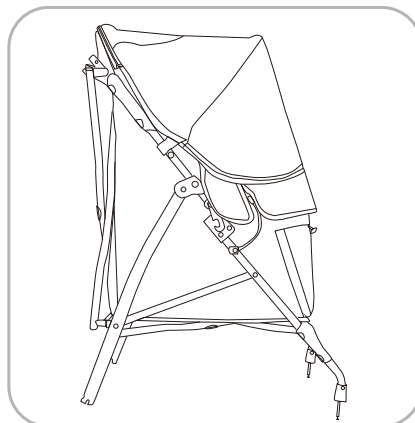
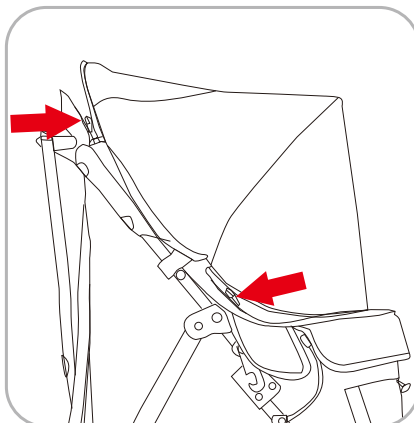
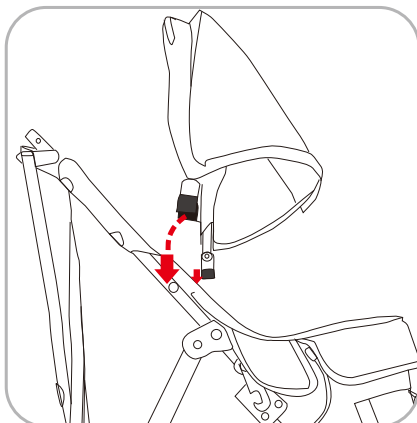

## 2. Installare la cappottina

Agganciare le clip della cappottina al tubo, che devono essere fissate sopra la colonna di limitazione. Quindi chiudere la cerniera

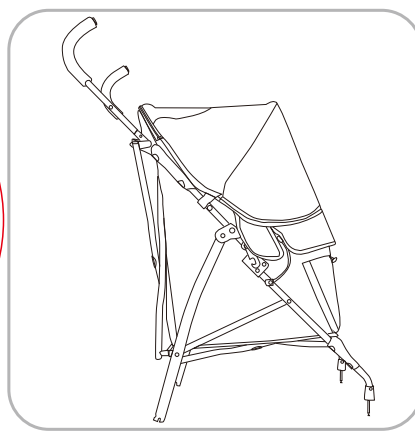
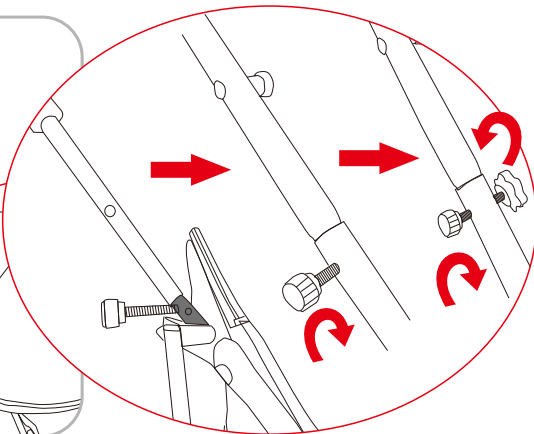
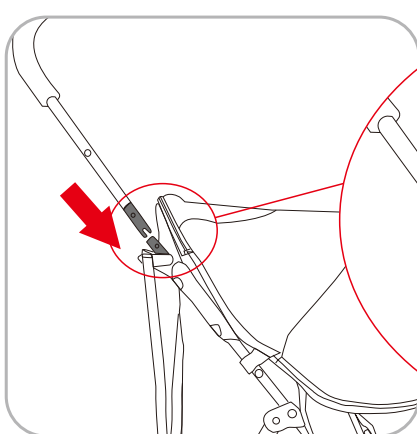

## 3. Installare il tubo superiore del manubrio

Allineare il tubo superiore del manubrio con il tubo inferiore del manubrio, inserirlo, installare la vite e serrare il dado. In caso contrario, il tubo superiore del manubrio può essere rimosso.

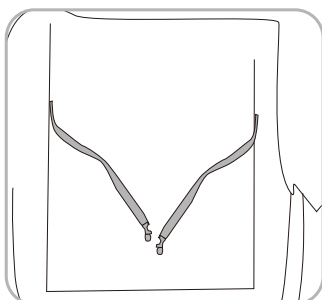
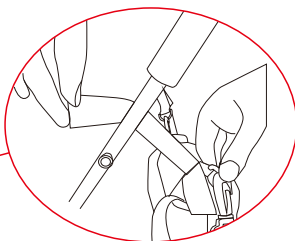
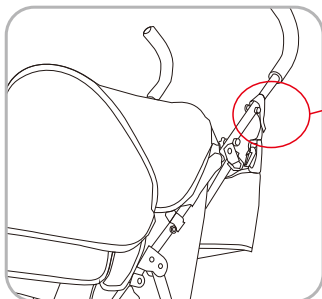
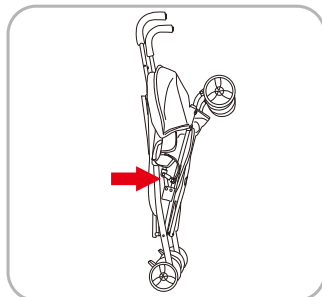
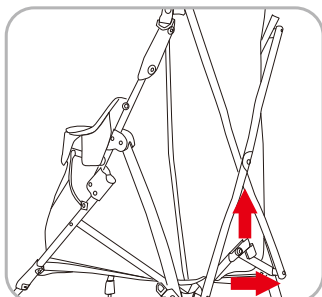
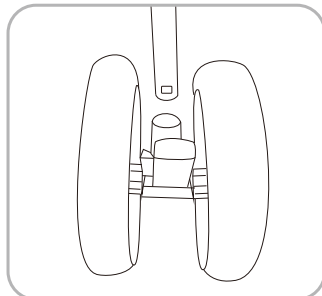
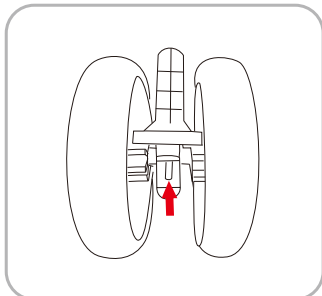
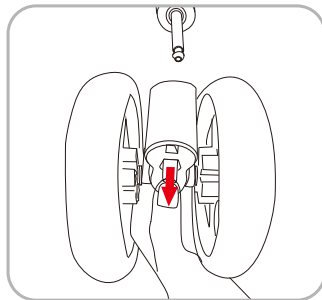
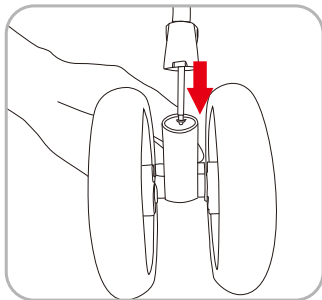

#### 4. Installazione e smontaggio della ruota anteriore

Installazione e smontaggio del gruppo ruota anteriore: inserire il gruppo ruota anteriore nel nucleo di copertura del tubo del piede anteriore, quando la barra del nucleo di copertura della ruota anteriore fuoriesce, l'installazione è corretta. Se è necessario smontare la ruota anteriore, è sufficiente tenere la barra ed estrarre le ruote, quindi il gruppo ruota anteriore verrà smontato.

#### 5. Installazione e smontaggio della ruota posteriore

Inserire il gruppo ruota posteriore nel tubo del piede posteriore, quando il pezzo di molla esce e il blocco è OK, premere il pezzo di molla ed estrarre le ruote, la ruota posteriore può essere smontata.

#### 6. Piegare il telaio

In fase di frenata, estrarre la piastra inferiore, agganciare il meccanismo di bloccaggio verso l'esterno e verso l'alto con il piede, tenere il manubrio in avanti e verso l'interno per chiuderlo. Il telaio è piegato, quindi appendere il gancio.

#### 7. Installare il sacco a pelo

Fissare il Fibbia in nylon su entrambi i lati della borsa per mummia sopra la colonna di fine corsa sul tubo superiore del manubrio.

#### 8. Frenare:

Premere le leve del freno della ruota posteriore su entrambi i lati.

Guida:

Agganciare le leve del freno della ruota posteriore su entrambi i lati.

9. Per le cinture di sicurezza per animali domestici.

If you have any questions, please contact our customer care center, Our contact details are below:

**US**

 001-877-644-9366

 customerservice@aosom.com

Imported by Aosom LLC  
27150 SW Kinsman Rd Wilsonville, OR 97070 USA  
MADE IN CHINA

If you have any questions, please contact our customer care center, Our contact details are below:

**CA**

 416-792-6088

 customerservice@aosom.ca

Imported by Aosom Canada Inc.  
7270 Woodbine Avenue, Unit 307, Markham,  
Ontario Canada L3R 4B9  
MADE IN CHINA

Si vous avez la moindre question, veuillez contacter notre centre d'assistance à la clientèle, Nos coordonnées sont les suivantes:

 416-792-6088

 customerservice@aosom.ca

Importé par Aosom Canada Inc.  
7270 Woodbine Avenue, unité 307,  
Markham, Ontario Canada L3R 4B9  
FABRIQUÉ EN CHINE

If you have any questions, please contact our customer care center, Our contact details are below:

**UK**

 0044-800-240-4004

 enquiries@mhstar.co.uk

IMPORTER ADDRESS:  
MH STAR UK LTD  
Unit 27, Perivale Park,  
Horsenden lane South  
Perivale, UB6 7RH  
MADE IN CHINA

Si vous avez la moindre question, veuillez contacter notre centre d'assistance à la clientèle, Nos coordonnées sont les suivantes:

**FR**

 0033-1-84166106

 aosom@mhfrance.fr

Importé par/Fabricant/REP:  
MH FRANCE  
2 Rue Maurice Hartmann  
92130 Issy Les Moulineaux  
France  
FABRIQUÉ EN CHINE

Wenn Sie Fragen haben, wenden Sie sich bitte an unser Kundendienstzentrum, Unsere Kontaktdaten stehen unten:

**DE**

 0049-0(40)-88307530

 service@aosom.de

ADRESSE DES IMPORTEURE/Hersteller/REP:  
MH Handel GmbH  
Wendenstraße 309  
D-20537 Hamburg  
Germany  
IN CHINA HERGESTELLT

In caso di dubbio, si prega di contattare il nostro centro assistenza clienti, I nostri dettagli di contatto sono di seguito:

**IT**

 0039-0249471447

 clienti@aosom.it

IMPORTATO DA/Produttore/REP:  
AOSOM Italy srl  
Centro Direzionale Milanofiori  
Strada 1 Palazzo F1  
20057 Assago (MI)  
P.I.: 08567220960  
FATTO IN CINA

Si tiene alguna pregunta, comuníquese con nuestro Centro de Atención al Cliente, Nuestros datos de contacto son los siguientes:

**ES**

 0034-931294512

 atencioncliente@aosom.es

IMPORTADOR/Fabricante/REP:  
SPANISH AOSOM, S.L.  
C/ROC GROS, N°15.08550, ELS HOSTALETES DE  
BALENYÀ, SPAIN.  
B66295775  
HECHO EN CHINA

Se tiver alguma dúvida, por favor contacte o nosso Centro de Atendimento ao Cliente, Os nossos dados de contacto são os seguintes:

**PT**

 0034-931294512

 info@aosom.pt.

IMPORTADOR/Fabricante/REP:  
SPANISH AOSOM, S.L.  
C.ROC GROS N.15, 08550. ELS HOSTALETES DE  
BALENYÀ  
FEITO NA CHINA



**FR**

**DONNEZ  
OU  
RECYCLEZ**



ASSOCIATION

OU



LIVRAISON

OU



DÉCHÈTERIE

Adresses sur [quefairedemesdechets.fr](http://quefairedemesdechets.fr)