

Force 300

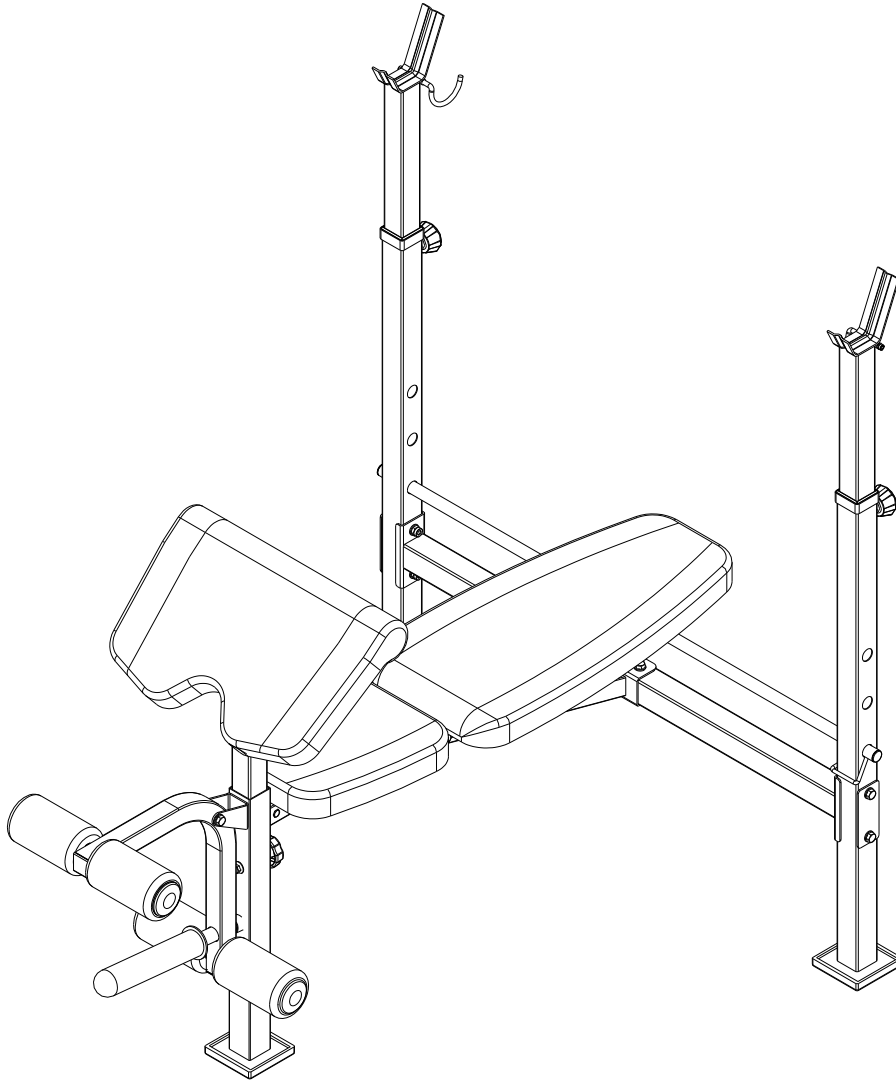

FOCUS
FITNESS

1 PART LIST / ONDERDELENLIJST

NO	DESCRIPTION	QTY
1	Upright Support	2
2	Cross bar	1
3	Main Frame	1
4	Front Upright	1
5	Arm Curl Pad	1
6	Leg Extension	1
7	Backrest Tube	2
8	Back Cushion	1
9	Seat Cushion	1
10	Left Hook	1
11	Right Hook	1
12	Curl Post	1
13	Foam Tube	2
14	Backrest Support	1
15	Barbell Support	2
16	Joint Plate	2
17	Plum Knob	1
18	Fast Pin	2
19	Foam Cap	4
20	Hex Bolt M6*16	6
21	Hex Bolt M6*40	4
22	Lock Nut M8	2
23	Lock Nut M6	2
24	Bolt M10*65	1
25	Bolt M10*75	2
26	Olympic Adapter	1
27	Hex Bolt M10*135	1
28	Washer ϕ 6	10
29	Washer ϕ 8	2
30	Washer ϕ 10	16
31	Hex Bolt M8*45	2
32	Lock Nut M10	8
33	Bolt M10*70	4
34	Bushing	2
35	Rubber Pad	3
36	Round Plug Φ 25	1
37	Square Plug 25*25	4

Force 300

38	Buffer	1
39	Square Plug 38*38	2
40	Foam Roller	4

2 OVERVIEW DRAWING / OVERZICHTSTEKENING

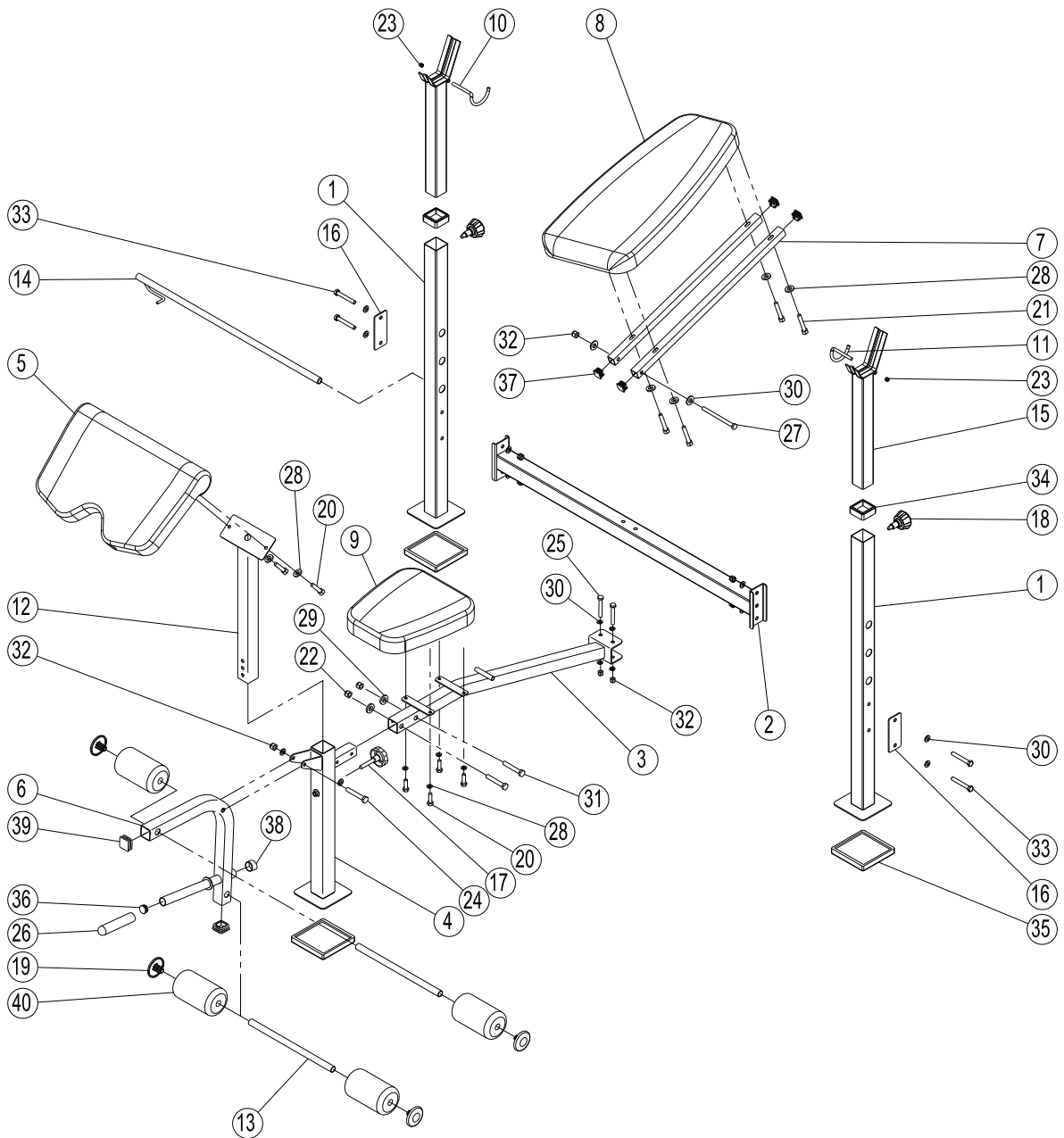

Force 300

3 ASSEMBLY / MONTAGE

STEP 1 / STAP 1

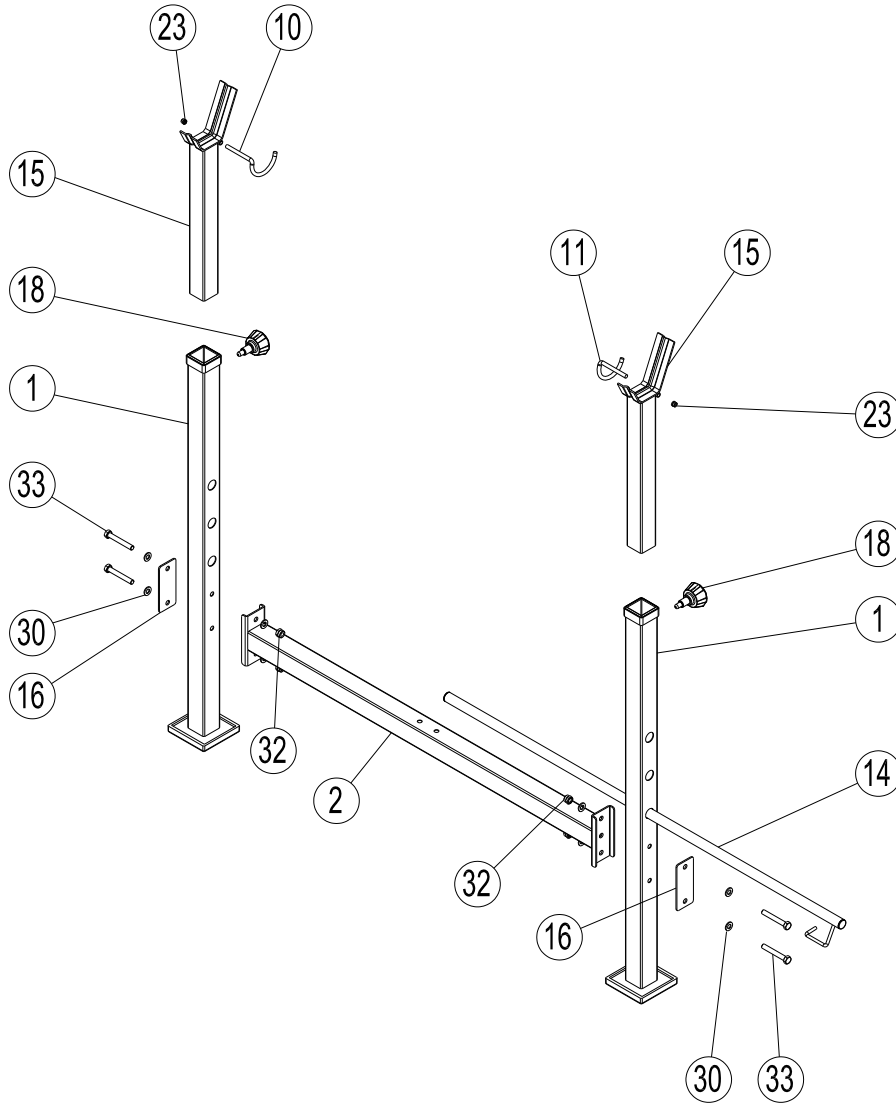

1#		Qty:2	16#		Qty:2		
2#		Qty:1	18#		Qty:2		
10#		Qty:1	23#		M6	Qty:2	
11#		Qty:1	30#		10	Qty:8	
14#		Qty:1	33#		M10*70	Qty:4	
15#		Qty:2	32#		M10	Qty:4	

Force 300

STEP 2 / STAP 2

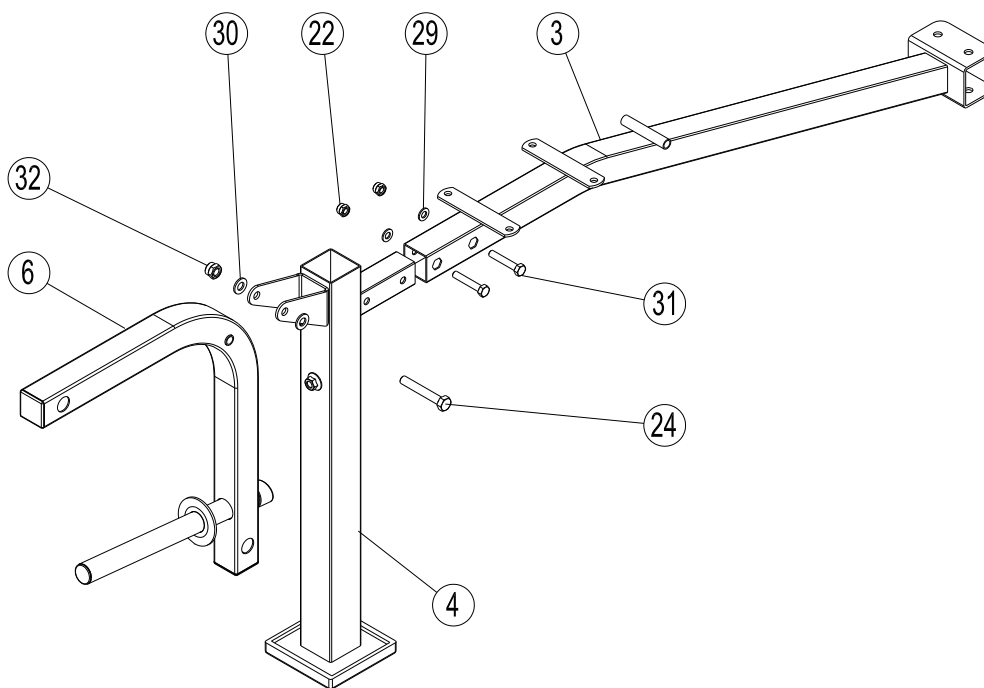





3#		Qty:1	
4#		Qty:1	
6#		Qty:1	
22#		M8	Qty:2
24#		M10*65	Qty:1

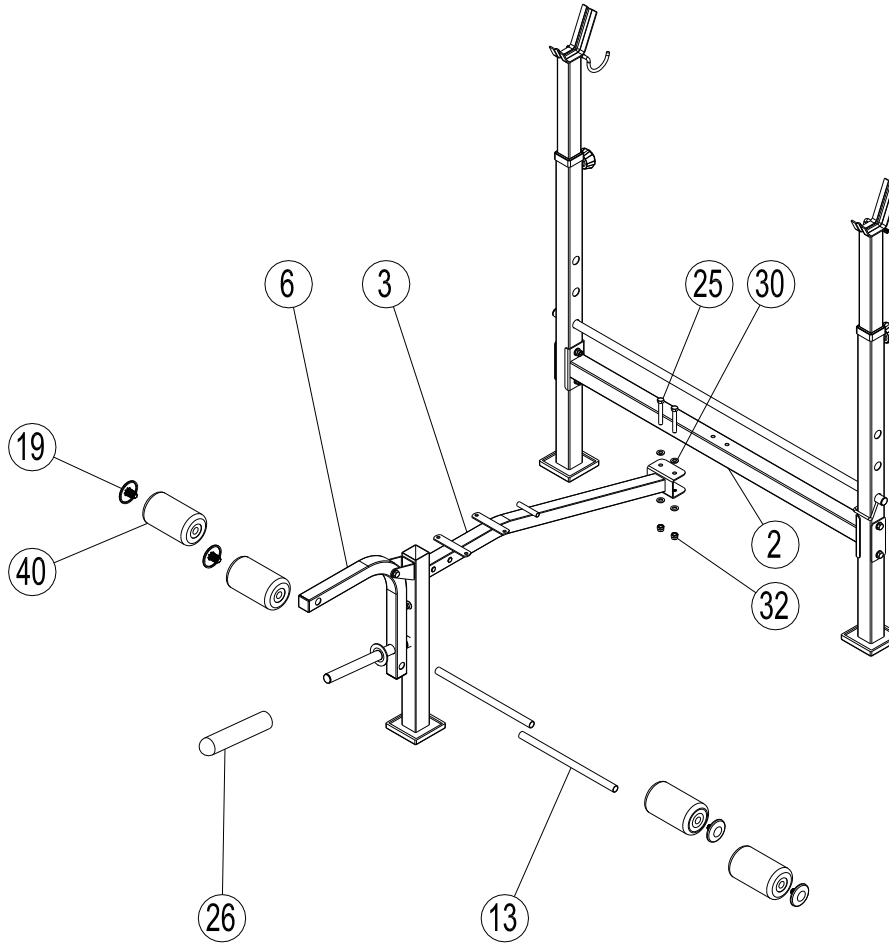

29#		8	Qty:2
30#		10	Qty:2
31#		M8*45	Qty:2
32#		M10	Qty:1

Force 300

STEP 3 / STAP 3









13#		Qty:2
19#		Qty:4
26#		Qty:1
40#		Qty:4

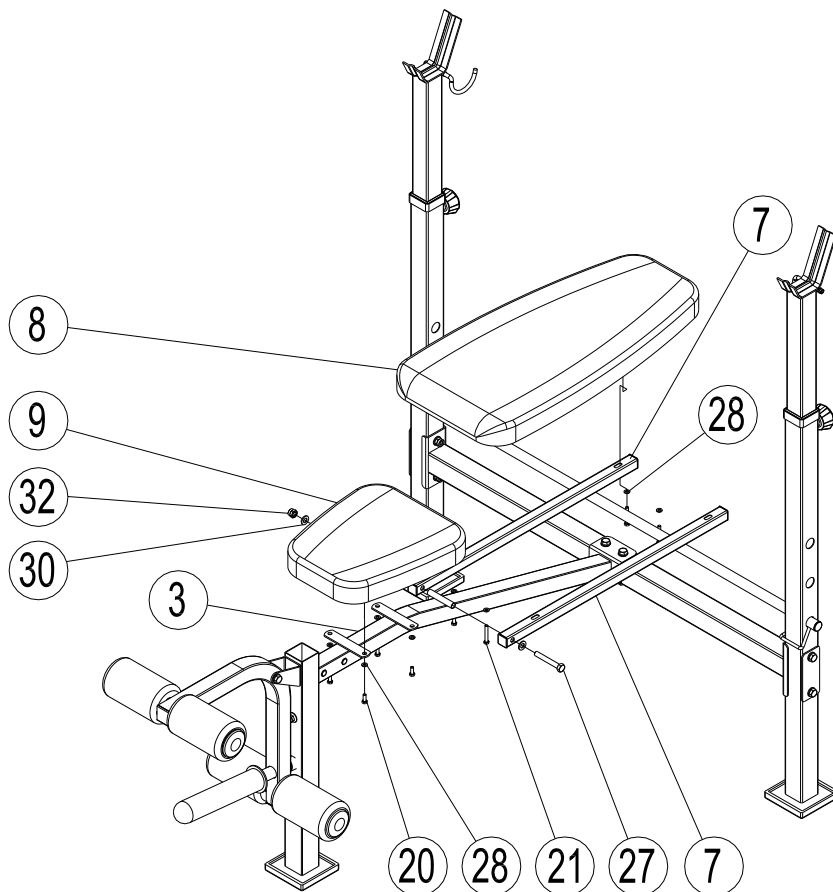



25#		M10*75	Qty:2
30#		10	Qty:4
32#		M10	Qty:2

Force 300

STEP 4 / STAP 4







7#		Qty:2	
8#		Qty:1	
9#		Qty:1	
20#		M6*16	Qty:4
21#		M6*40	Qty:4

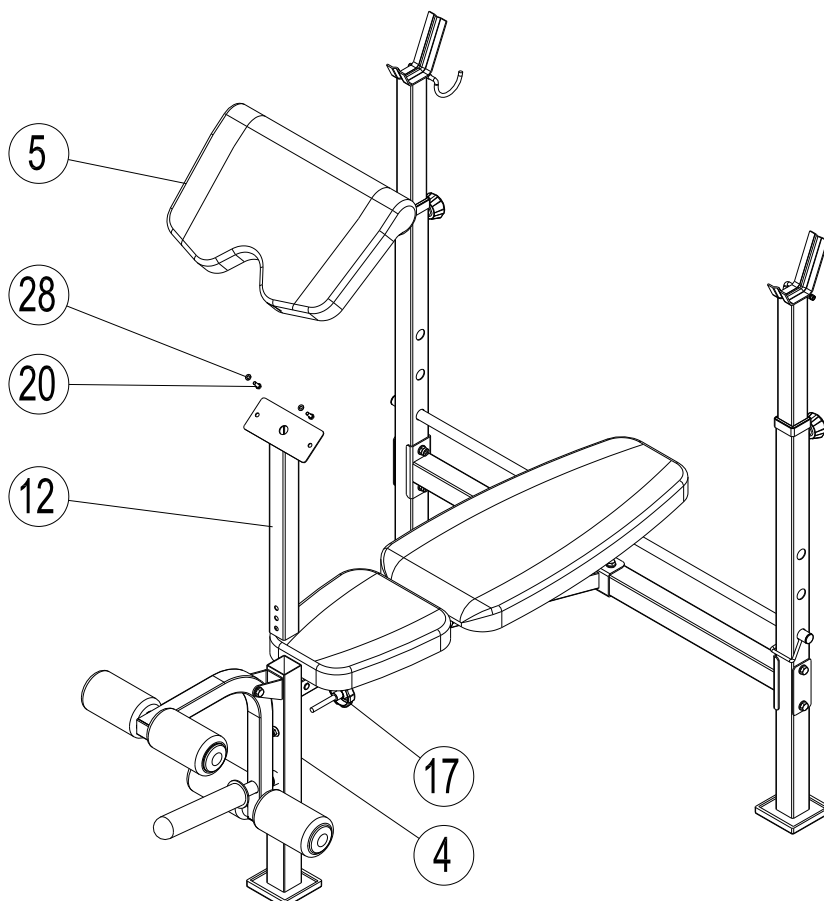

27#		M10*135	Qty:1
28#		6	Qty:8
30#		10	Qty:2
32#		M10	Qty:1

Force 300

STEP 5 / STAP 5



5#		Qty:1
12#		Qty:1
17#		Qty:1

20#		M6*16	Qty:2
28#		6	Qty:2