

Soozier

IN221000258V02_US_CA

A61-039V00_A61-040V00

EN

Basketball Backboard

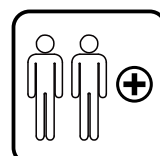
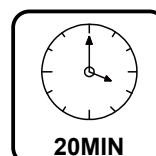
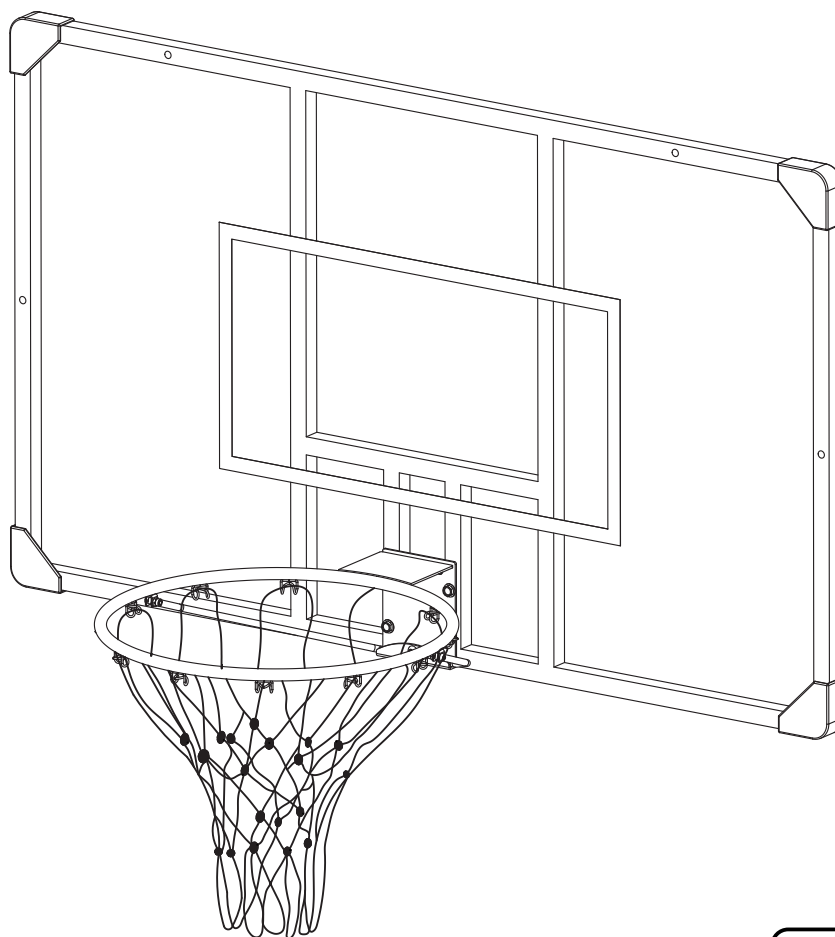

IMPORTANT, RETAIN FOR FUTURE REFERENCE: READ CAREFULLY

USER MANUAL

General Safety Instructions

- Two capable adults are required for this assembly.
- Read and understand the manual before assembling and using the unit.
- Failure to follow the instructions could result in injury or damage to the property.
- Select a safe place to install the backboard.
- Use extreme caution when using ladder.
- Make sure the backboard is firmly installed.
- Do not hang from the backboard and rim.
- Remove all contents from box and make sure this matches the parts list.
- Do not return the product in store, please contact customer service.

Maintenance

1. Regularly check if the backboard is firmly attached on the wall or mounting bracket. It is required to tighten if the screws are loose.
2. Check your basketball system frequently for loose hardware, excessive wear; and signs of corrosion.

For safety reasons, and to prolong the life of your basketball system, you must take the following preventative measures.

(1) Check all nuts and bolts. If any are loose, tighten them.

(2) Check all parts for excessive wear and tear. If necessary replace any parts that have been worn or damaged through usage. Contact our Customer Service Department for replacement parts.

Note: DO NOT HANG FROM RIM

Part List

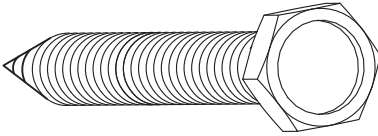
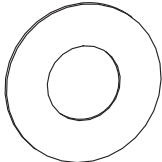
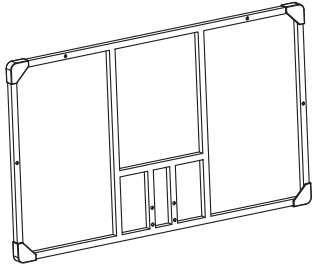
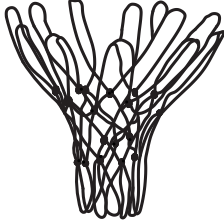
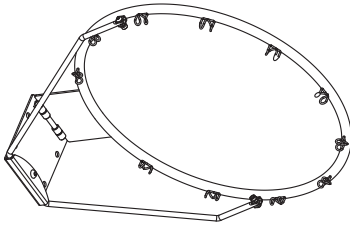
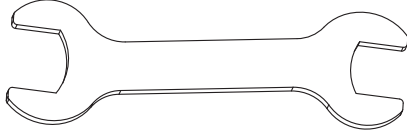
	DESCRIPTION	PART IMAGE	Qty
1	Wall plug		8
2	Bolts		8
3	Washer		8
4	Backboard		1
5	Net		1
6	Rim		1
7	Tools		1

Assembly

Step 1

Find a suitable wall/board for ball-shooting.

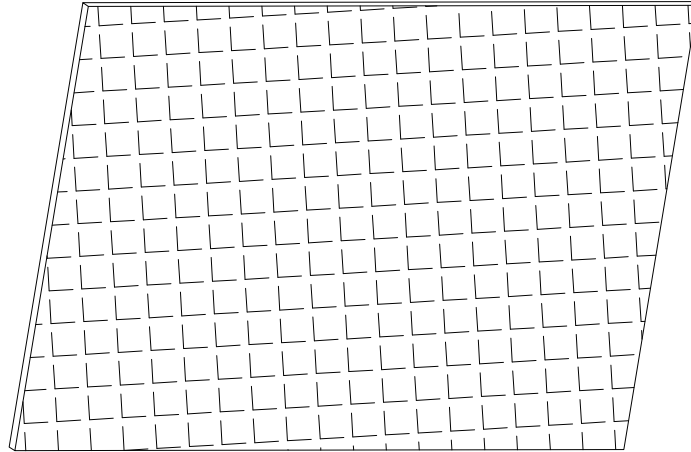

Step 2

Place the backboard(#4) on desired areas to navigate & prepare for drilling.

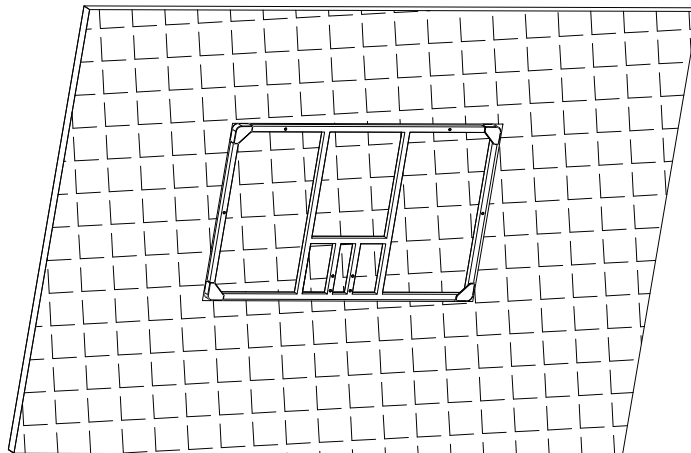

Step 3

Drill the wall/board according to the location of the backboard, and stuff the Wall plug (#1 * 8) into the holes.

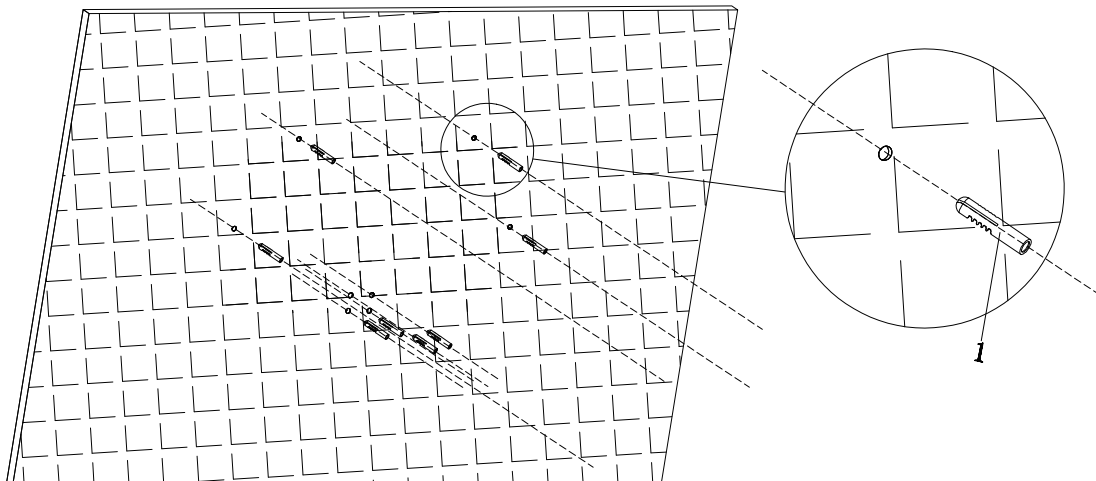

Step 4

Locking the basketball hoop.

- Align the backboard (#4) with the corresponding holes, and put in 4 sets of Bolts (#2) and washer (#3). Tighten the screws.
- Align the Rim (#6) with 4 holes located at the bottom of the backboard, and put in 4 sets of Bolts (#2) and washer (#3). Tighten the screws.
- Hang the basketball net (#5).
- Assembly Complete.

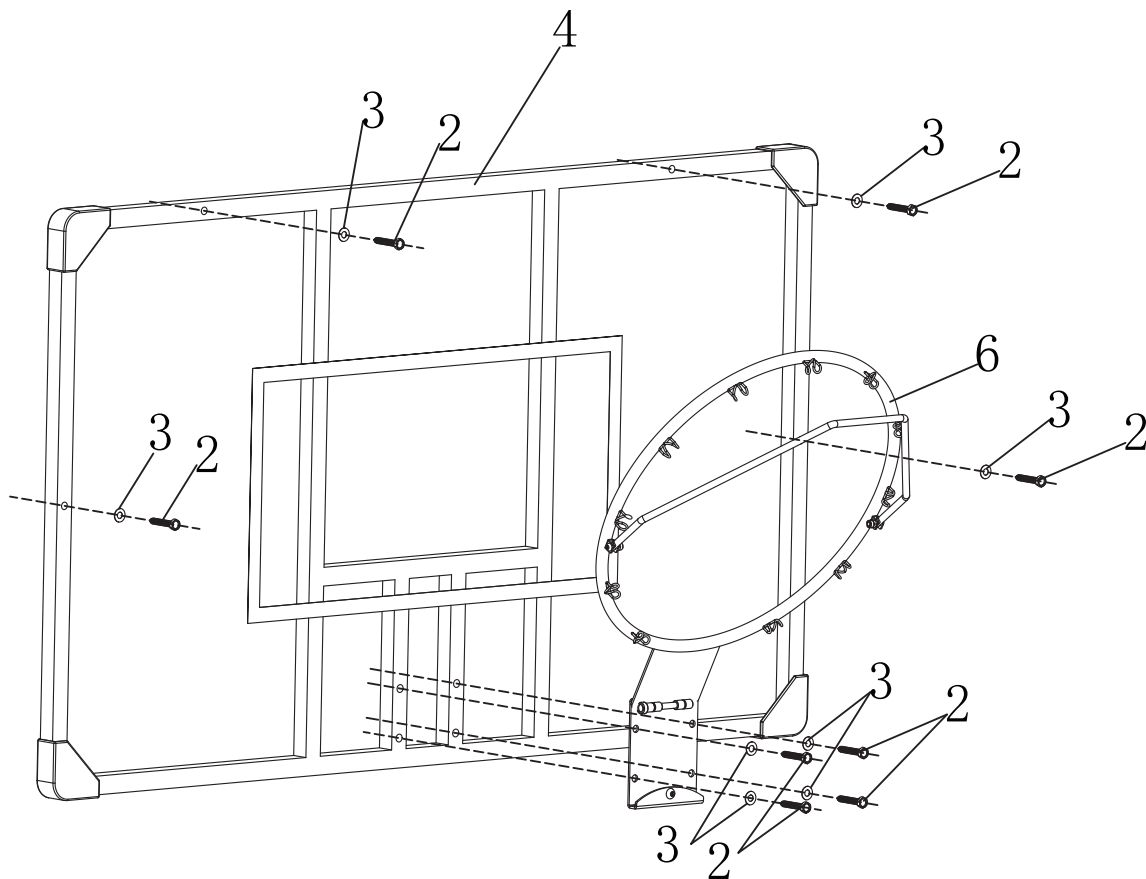

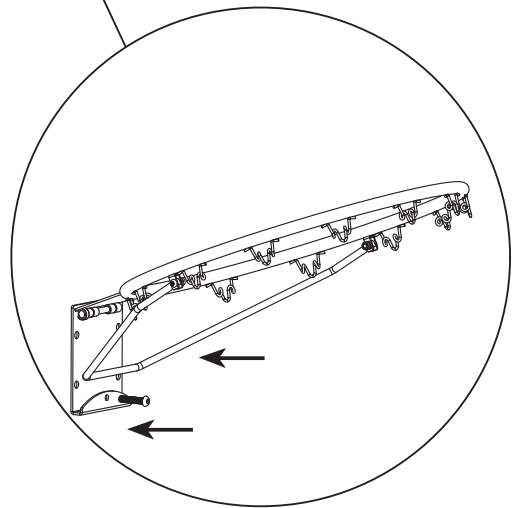
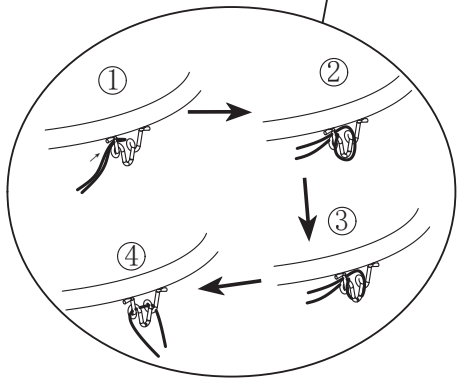
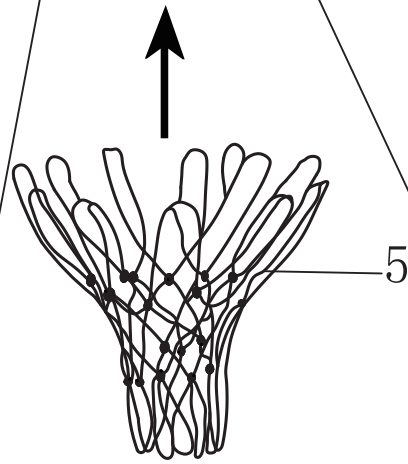
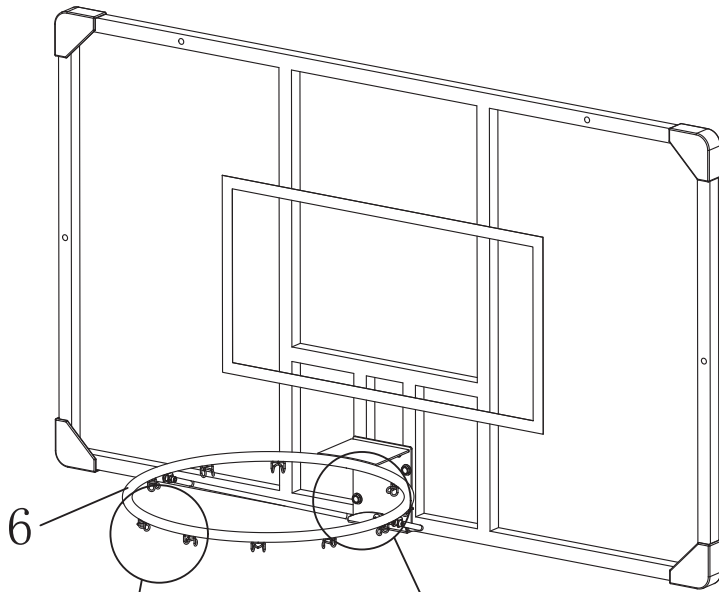

Soozier

IN221000258V02_US_CA

A61-039V00_A61-040V00

FR

Panneau de basketball

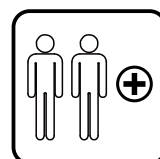
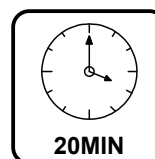
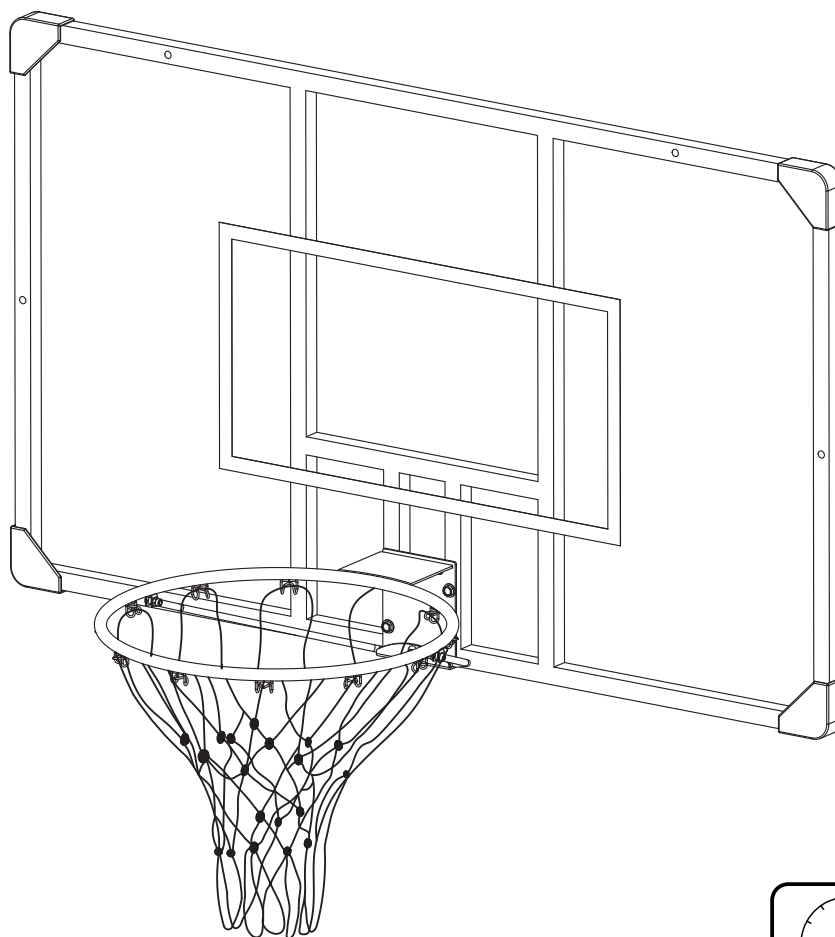

**IMPORTANT, CONSERVEZ LES INSTRUCTIONS
POUR RÉFÉRENCE ULTÉRIEURE : LISEZ ATTENTIVEMENT**

Manuel d'Instructions

Consignes de sécurité générales

- Deux adultes aptes sont requis pour cet assemblage.
- Lisez attentivement le manuel avant d'assembler et d'utiliser l'appareil.
- Le non-respect des instructions pourrait entraîner des blessures ou des dommages au matériel.
- Sélectionnez un endroit sûr pour installer le panneau arrière.
- Soyez extrêmement prudent lorsque vous utilisez une échelle.
- Assurez-vous que le panneau arrière est bien installé.
- Ne vous suspendez pas au panneau arrière et au cerceau.
- Retirez tout le contenu de la boîte et veillez à ce qu'il corresponde à la liste des pièces.
- Ne retournez pas le produit en magasin, veuillez contacter le service après-vente.

Entretien

1. Vérifiez régulièrement si le panneau arrière est fermement fixé au mur ou au support de montage. Il est nécessaire de serrer les vis s'ils sont desserrés.
2. Vérifiez fréquemment que votre système de basket-ball ne présente pas de pièces desserrées, d'usure excessive ou de signes de corrosion.

Pour des raisons de sécurité, et pour prolonger la durée de vie de votre système de basketball, vous devez prendre les mesures préventives suivantes.

- (1) Vérifiez tous les écrous et boulons. Si certains sont desserrés, serrez-les.
- (2) Vérifiez toutes les pièces pour détecter une usure excessive. Si nécessaire, remplacez toutes les pièces usées ou endommagées par l'utilisation. Contactez notre service clientèle pour obtenir des pièces de rechange.

Note : NE PAS SUSPENDRE AU CERCEAU

Liste des pièces

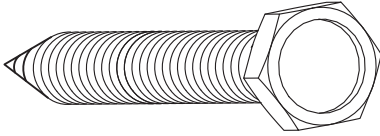
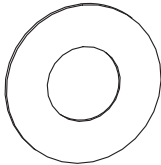
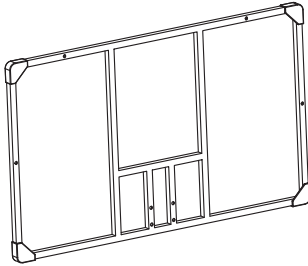
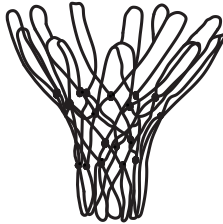
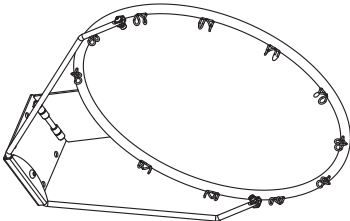
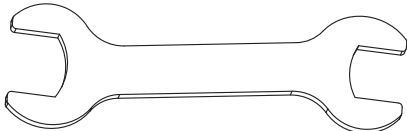
	DESCRIPTION	FIGURE DE LA PIÈCE	QTE
1	Prise		8
2	Boulon		8
3	Rondelle		8
4	Panneau		1
5	Filet		1
6	Cerceau		1
7	Outil		1

Assemblage

Étape 1

Trouvez un mur / tableau approprié pour le tir de balle.

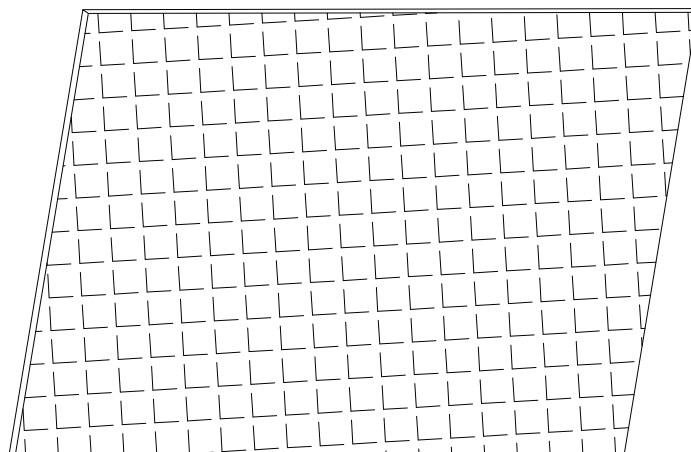

Étape 2

Placez le panneau arrière (# 4) sur les zones souhaitées pour naviguer et préparer le forage.

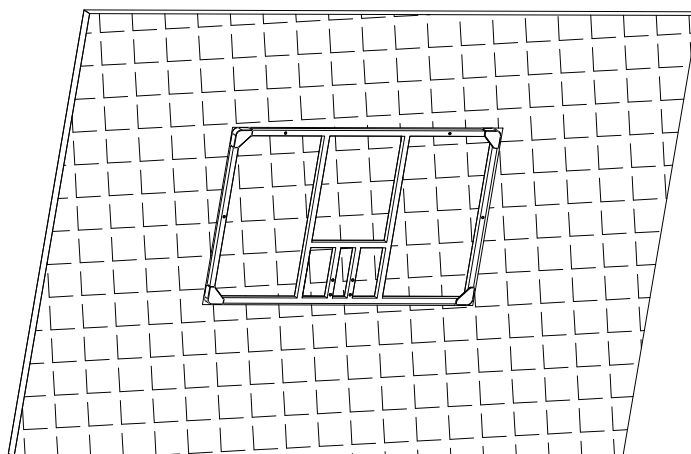

Étape 3

Percez le mur / planche en fonction de l'emplacement du panneau arrière et fourrez la prise murale (# 1 * 8) dans les trous.

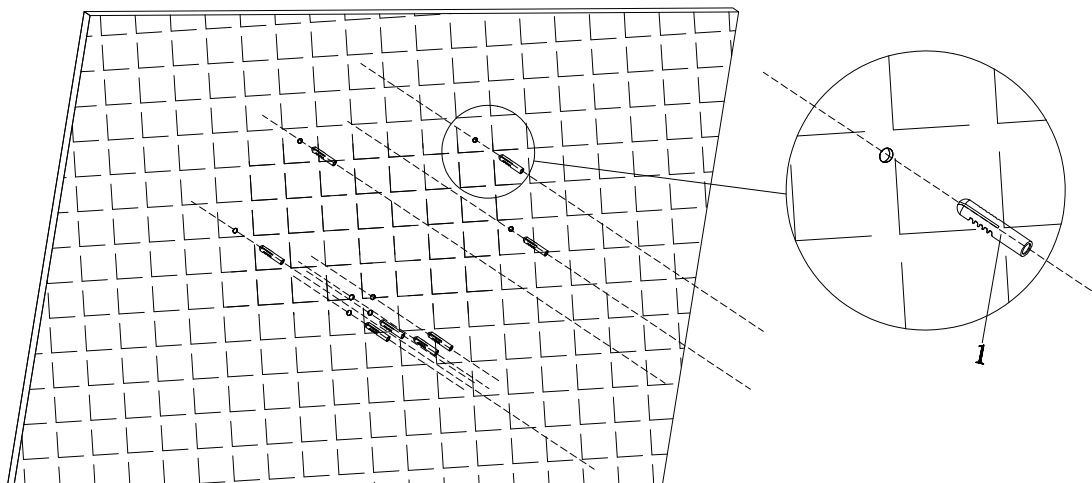

Étape 4

Verrouillez le panier de basketball.

- Alignez le panneau arrière (#4) avec les trous correspondants, et placez 4 jeux de boulons (#2) et une rondelle (#3). Serrez les vis.
- Alignez le cerceau (#6) avec 4 trous situés au bas du panneau arrière, et mettez en place 4 jeux de boulons (#2) et une rondelle (#3). Serrez les vis.
- Accrochez le filet de basket-ball (# 5).
- Assemblage terminé.

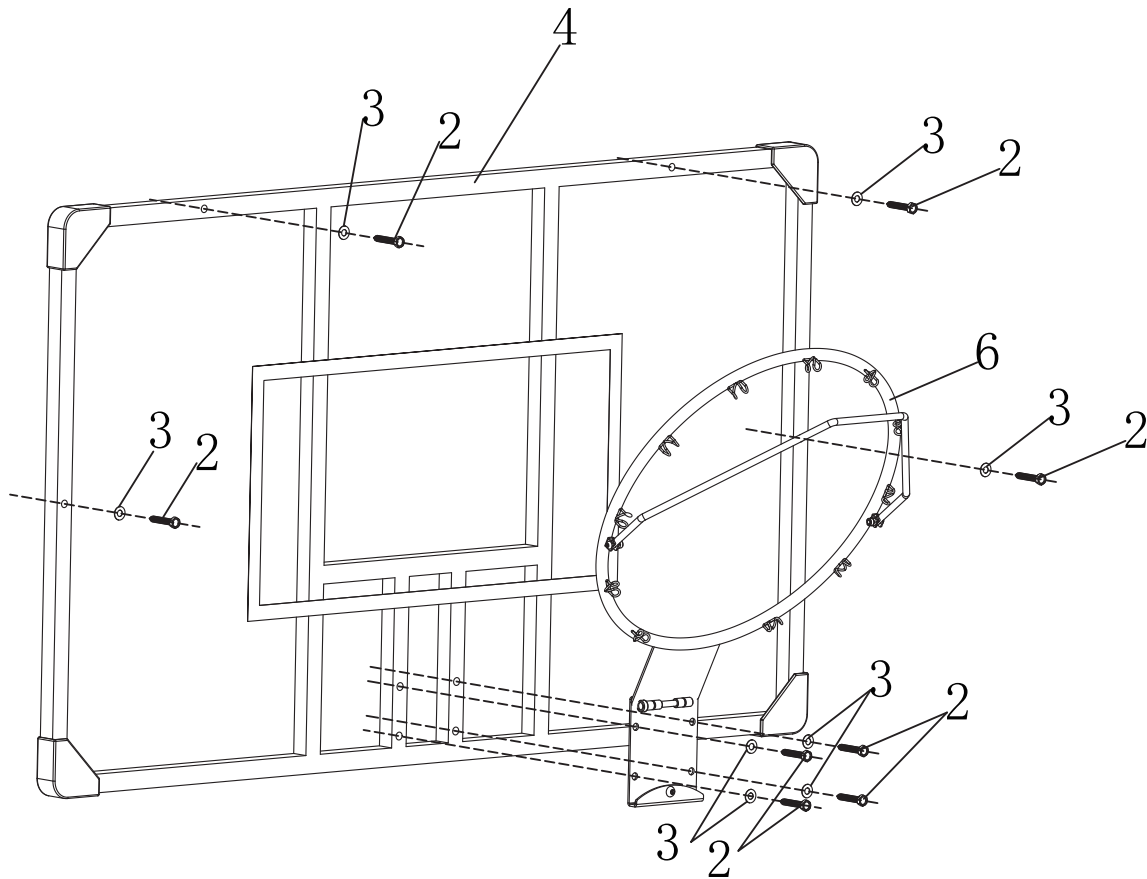

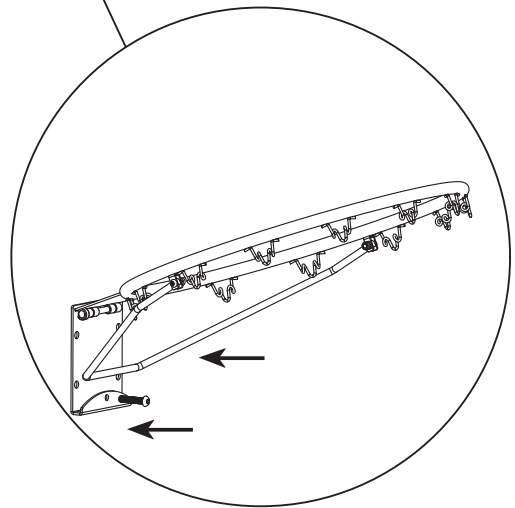
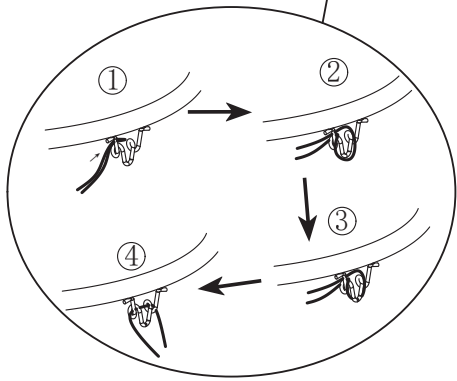
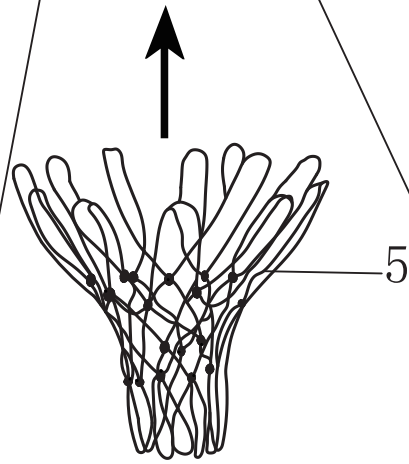
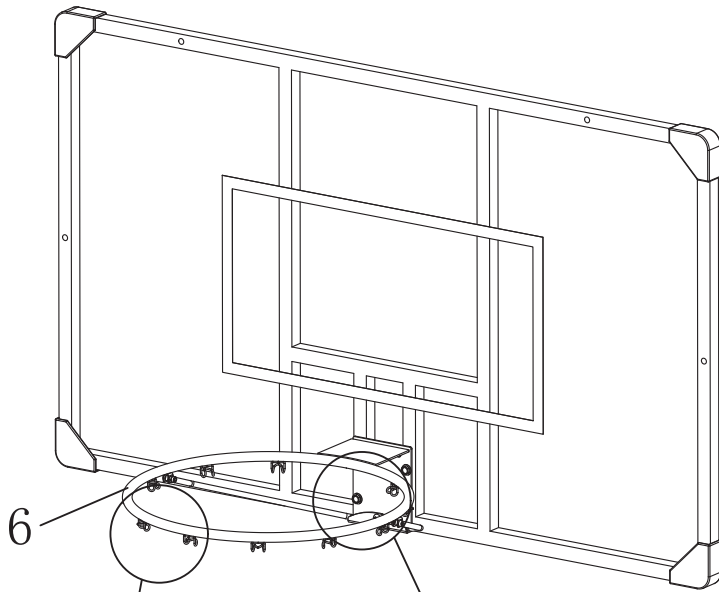

US

If you have any questions, please contact our customer care center.
Our contact details are below:



001-877-644-9366



customerservice@aosom.com

Imported by Aosom LLC
27150 SW Kinsman Rd Wilsonville, OR 97070 USA
MADE IN CHINA

CA

If you have any questions, please contact our customer care center.
Our contact details are below:

Si vous avez la moindre question, veuillez contacter notre centre d'assistance à la clientèle.
Nos coordonnées sont les suivantes:



416-792-6088



customerservice@aosom.ca

Imported by Aosom Canada Inc.
7270 Woodbine Avenue, Unit 307, Markham, Ontario Canada L3R 4B9
MADE IN CHINA

Importé par Aosom Canada Inc.
7270 Woodbine Avenue, unité 307, Markham, Ontario Canada L3R 4B9
Fabriqué en Chine