

Soozier

IN230600321V01_US_CA

A91-054V01

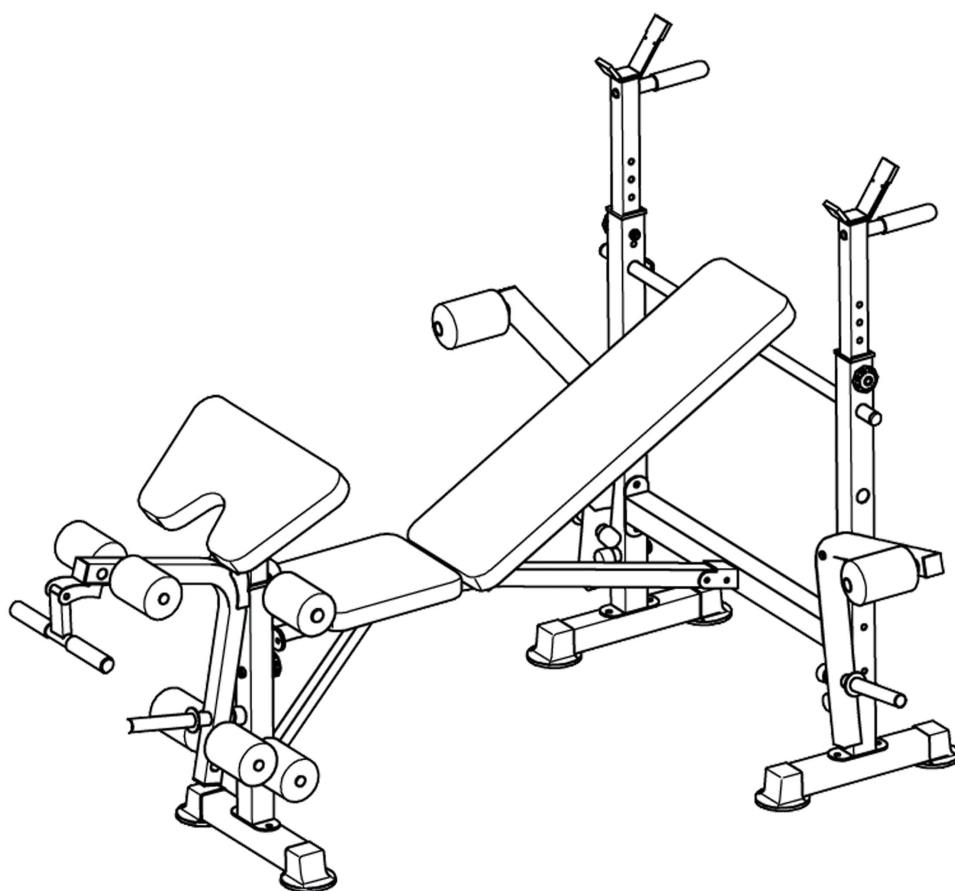

Assembly video please scan the QR code .
The Specifications of this product may vary from this photo,
subject to change with our notice







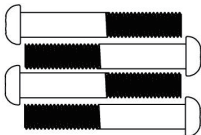
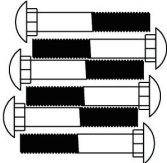
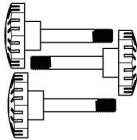

Assembly video please scan the QR code .
Les spécifications de ce produit peuvent varier par rapport à cette
illustration, sujets à changements sans préavis

**FR: IMPORTANT: A LIRE ATTENTIVEMENT ET A CONSERVER POUR VOUS Y
REFRERER ULTERIEUREMENT**
EN: IMPORTANT, RETAIN FOR FUTURE REFERENCE: READ CAREFULLY.

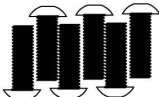
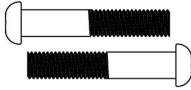

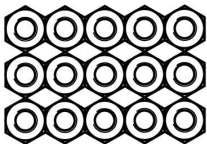
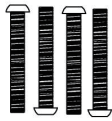



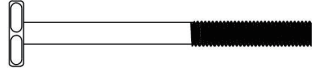
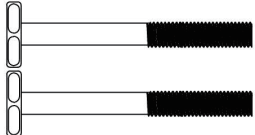
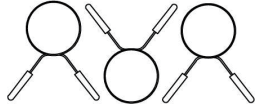
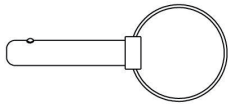
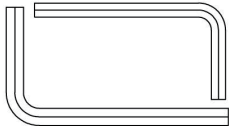
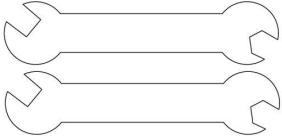

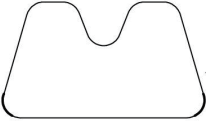
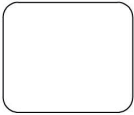
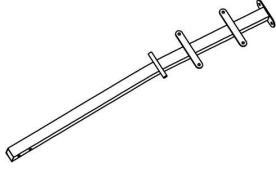
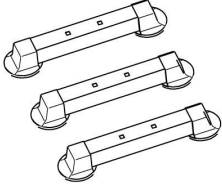
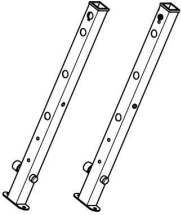
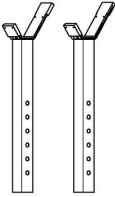

NOTICE !

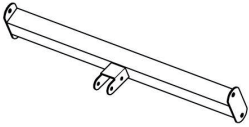
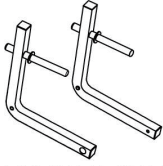
- Please retain these instructions for future reference.
- Please do not exceed the weight limitations of this item.
- Maximum Weight for users: 330lbs / 150kgs.
- Do not stand on or use any part of this item as a step ladder.
- Firmly secure all bolts, screws, and knobs before use.
- Fasten screws loosely during initial assembly. Do not firmly tighten the screws until the item is completely assembled.
- Be aware that some parts are heavy and have sharp edges.
- If any parts are missing, broken, damaged, or worn, stop using this product until repairs are made and/or factory replacement parts are installed.

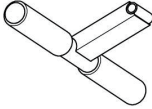
HARDWARE

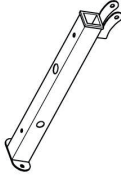
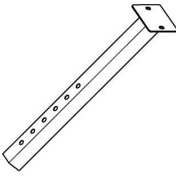
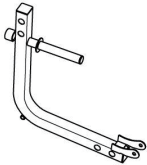
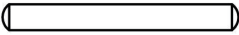
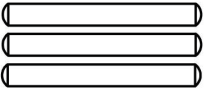
 <p>1. M10x65mm BOLT 4PCS</p>	 <p>2. M10x65mm CARRIAGE BOLT 6PCS</p>	 <p>3. M10x55mm KNOB 3PCS</p>	 <p>4. M8x55mm BOLT 1PC</p>
 <p>5. M8x20mm SCREW 6PCS</p>	 <p>6. M10x55mm BOLT 2PCS</p>	 <p>7. M8x16mm SCREW 2PCS</p>	 <p>8. M6x16mm SCREW 4PCS</p>
 <p>9. M10 NUT 15PCS</p>	 <p>10. M6x40mm BOLT 4PCS</p>	 <p>11. M10 WASHER 10PCS</p>	 <p>12. M8 WASHER 3PCS</p>
 <p>13. M8 NUT 3PCS</p>	 <p>14. M10x160mm HEX BOLT 1PC</p>	 <p>15. M10x130mm HEX BOLT 2PCS</p>	 <p>16. Ø25 CLAMP 3PCS</p>
 <p>17. M8x50mm PIN 1PC</p>	 <p>18. #6 ALLEN WRENCH 1PC 19. #8 ALLEN WRENCH 1PC</p>	 <p>20. 13-17 OPEN WRENCH 2PCS</p>	

PARTS

 <p>A. BACKREST PAD 1PC</p>	 <p>B. ELBOW PAD 1PC</p>	 <p>C. SEAT PAD 1PC</p>	 <p>D. MAIN FRAME 1PC</p>
 <p>E. SIDE LEG 3PCS</p>	 <p>F. SIDE FRAME 2PCS</p>	 <p>G. UPPER SIDE FRAME 2PCS</p>	 <p>H. ANGLE CONTROL ROD 1PC</p>
 <p>J. SQUARE SUPPORT 1PC</p>	 <p>K. ARM SUPPORT 2PCS</p>	 <p>L. ARM 2PCS</p>	 <p>M. HANDLE 1PC</p>
 <p>N. FIXED SUPPORT 1PC</p>	 <p>P. FRONT SUPPORT 1PC</p>	 <p>Q. ELBOW SUPPORT 1PC</p>	 <p>R. LEG FRAME 1PC</p>
 <p>S. Φ22 ROUND SUPPORT 1PC</p>	 <p>T. Φ19 ROUND SUPPORT 3PCS</p>	 <p>U. 17*73*130mm FOAM ROLLER 4PCS</p>	 <p>V. 13*70*125mm FOAM ROLLER 6PCS</p>
 <p>W. BACKREST FRAME 2PCS</p>			

REMARK: PLEASE NOTE THE LEFT AND RIGHT DIRECTION BETWEEN **PART F** (SIDE FRAME) AND **PART K** (ARM SUPPORT) DURING INSTALLATION!

PRODUCT ASSEMBLY

Step1: Attach two part E side legs to two part F side frames with four part 2 carriage bolts, four part 11 washers, and four part 9 nuts.

Insert two part G upper side frames and secure them with two part 3 knobs.

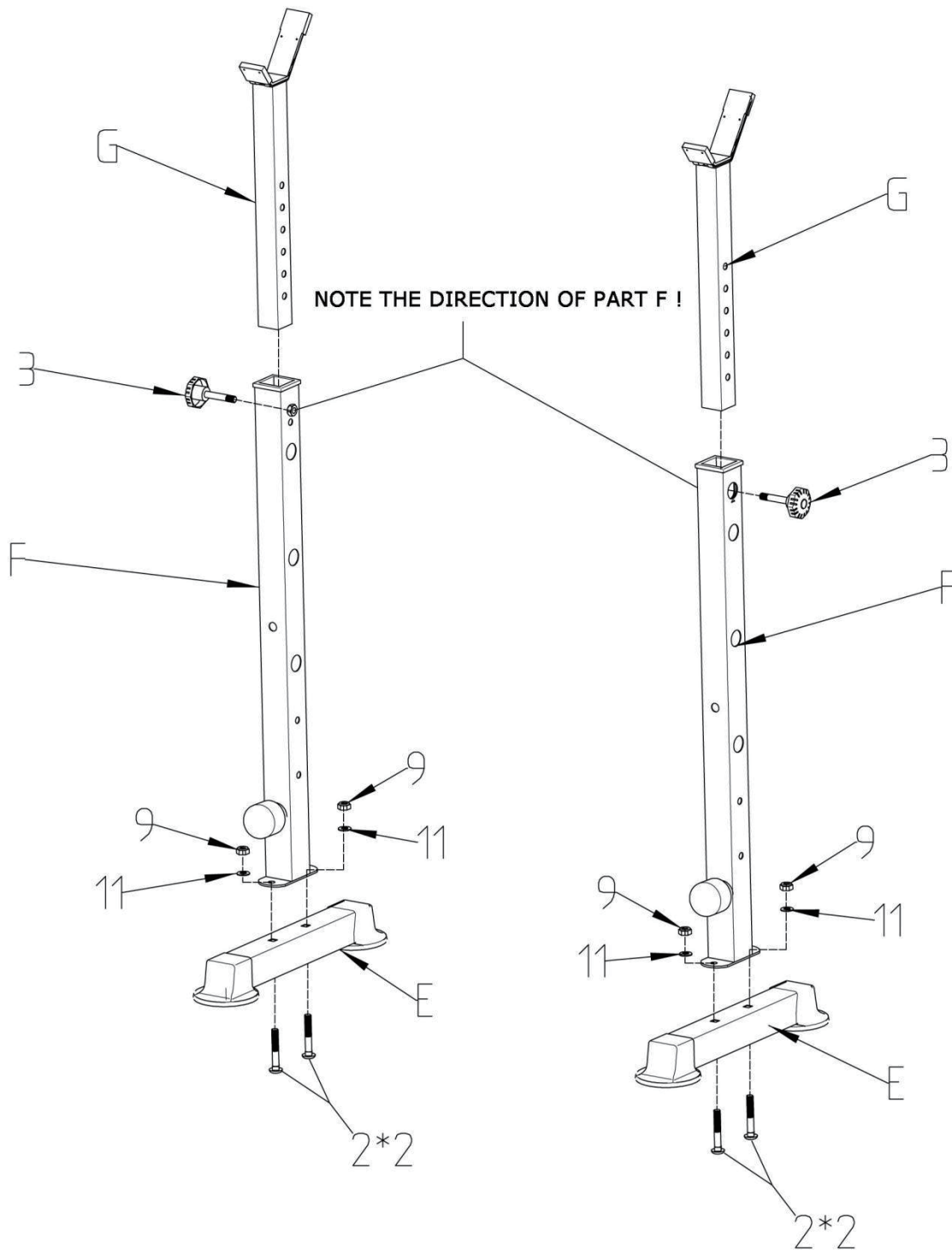

Step2: Attach part J square support to the side frames with four part 1 bolts, four part 11 washers, and four part 9 nuts. Insert part H angle control rod.

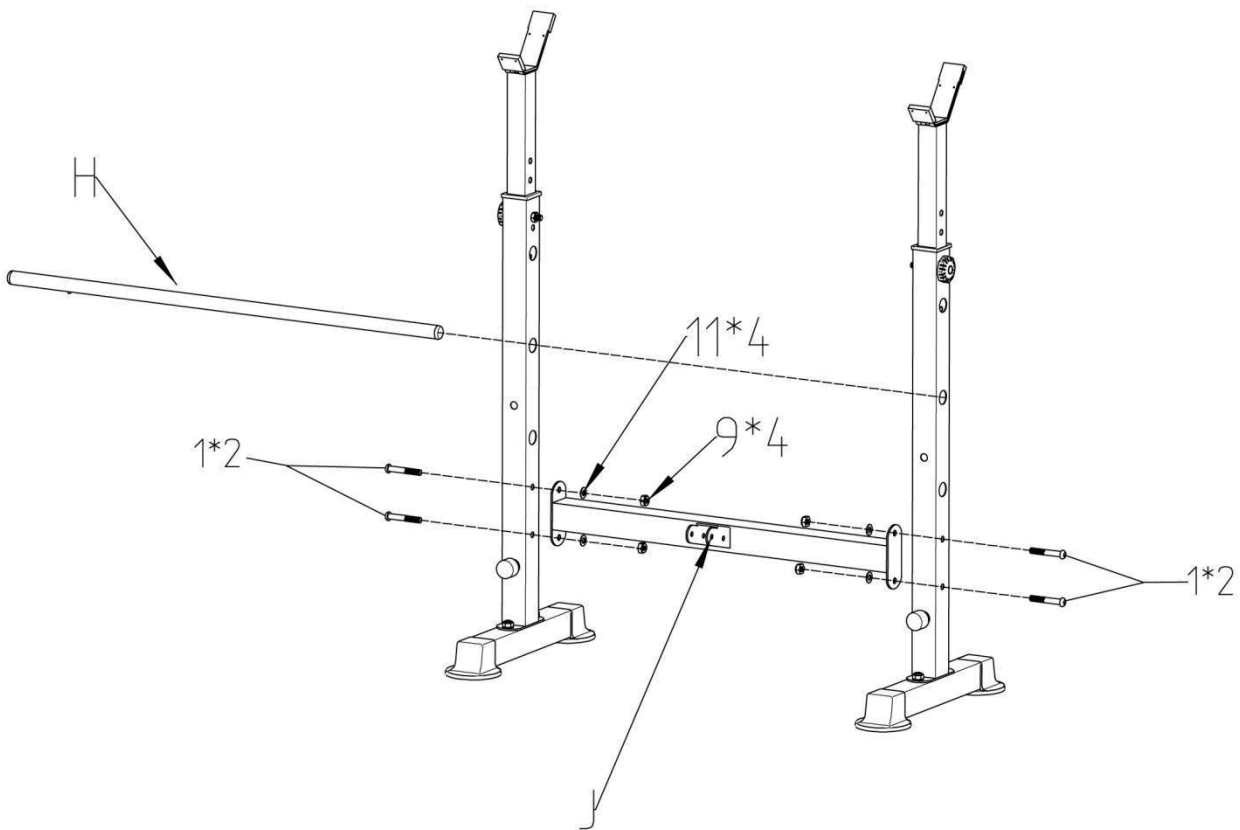

Step3: Attach two part L arms with two part U 17*73*130mm foam rollers, to two part K arm supports with two part 5 screws, two part 12 washers and two part 16 clamps.

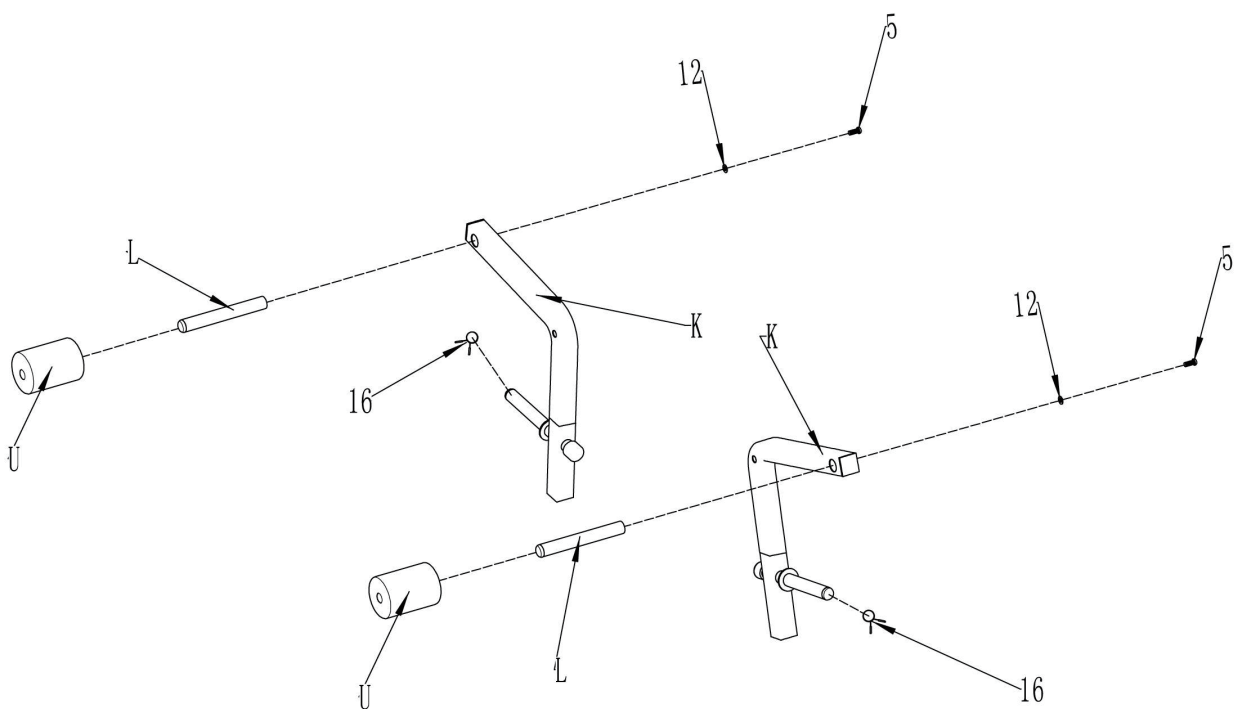

NOTE THE DIRECTION OF PART K !

Step4: Attach the arm supports to the side frames with two part 15 hex bolts and two part 9 nuts.

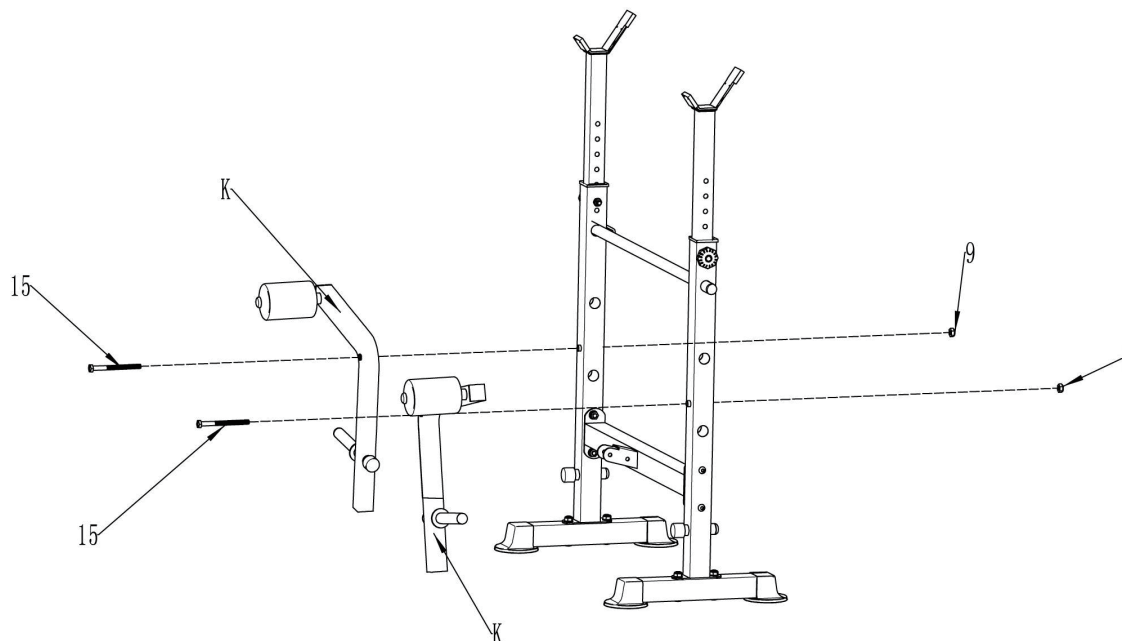

Step5: Attach part D main frame to part C seat pad with four part 8 screws.

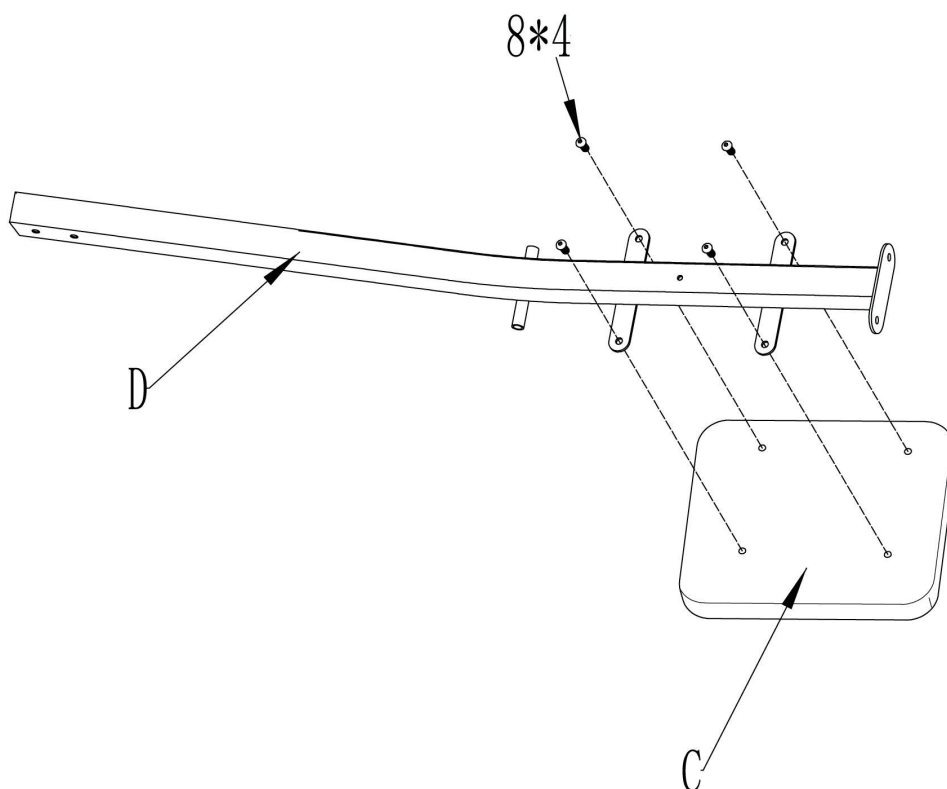

Step6: Attach part P front support to a part E side leg with two part 2 carriage bolts, two part 11 washers and two part 9 nuts.

Attach the main frame to the side frames with a part 4 bolt, part 12 washer and part 13 nut. Insert part 17 pin.

Attach the front support to the main frame with two part 7 screws and two part 13 nuts.

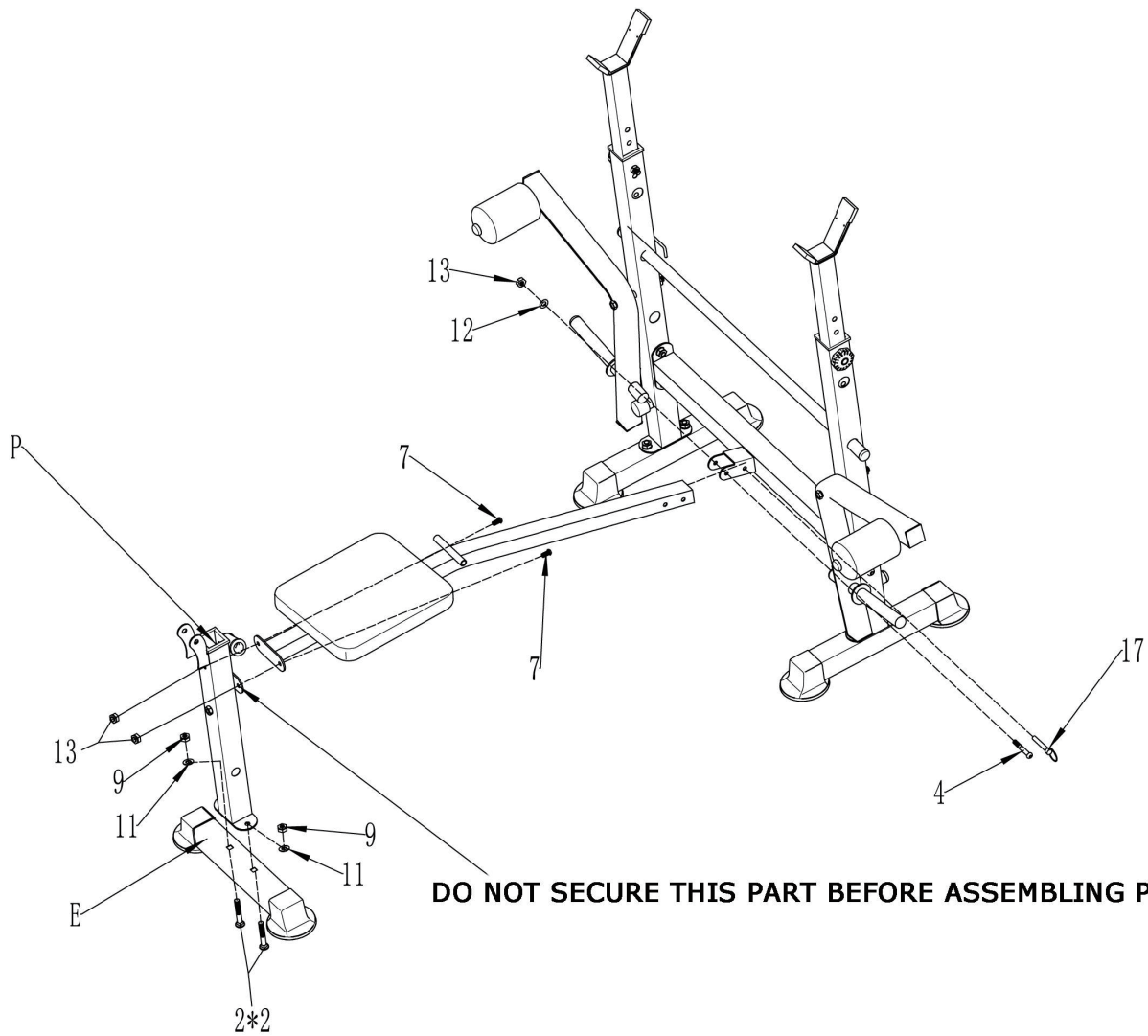

Step7: Attach part N fixed support to the main frame and front support with two part 5 screws.

Insert part S $\Phi 22$ round support with two part U 17*73*130mm foam rollers.

Insert a part T $\Phi 19$ round support with two part V 13*70*125mm foam rollers.

SECURE THIS PART AFTER ASSEMBLING PART N !

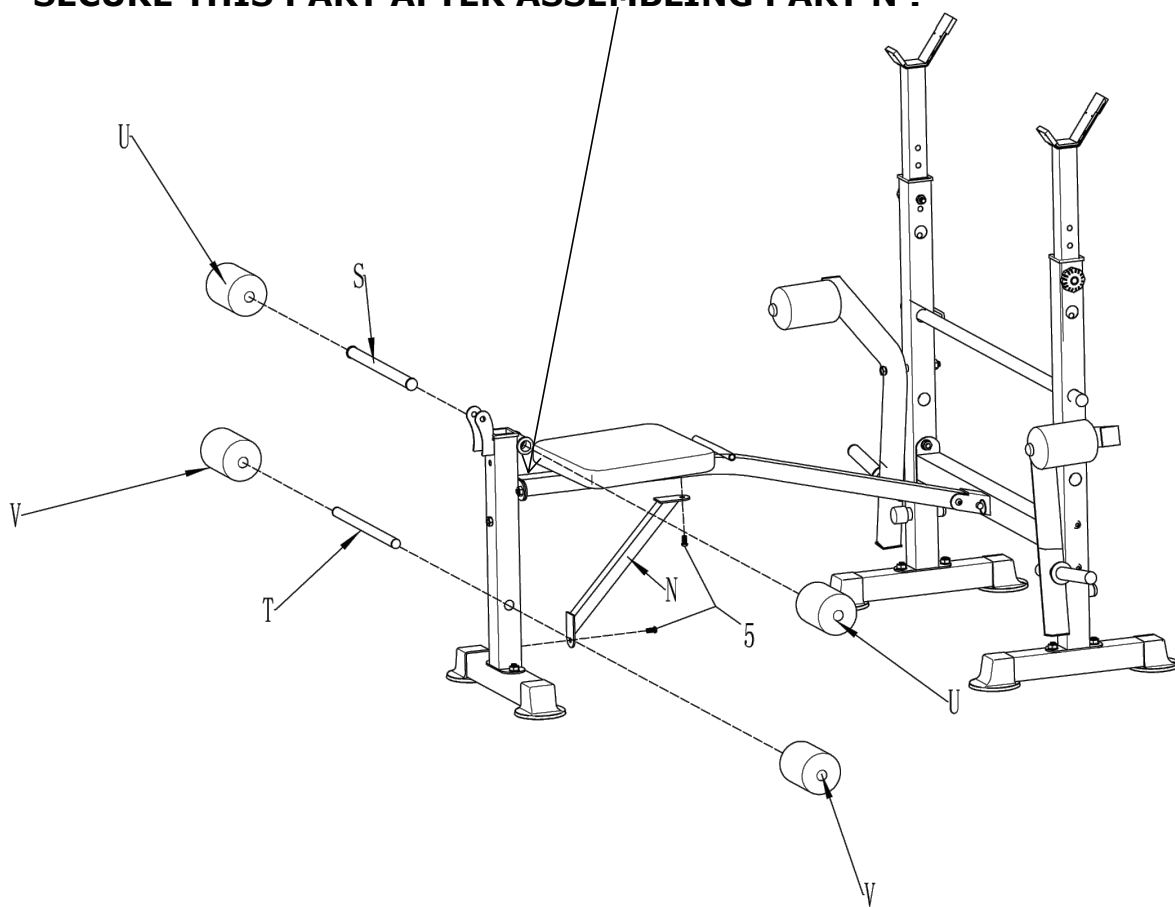

Step8: Attach part M handle to part R leg frame with a part 6 bolt, part 9 nut and part 16 clamp.

Insert two part T $\Phi 19$ round supports with four part V 13*70*125mm foam rollers.

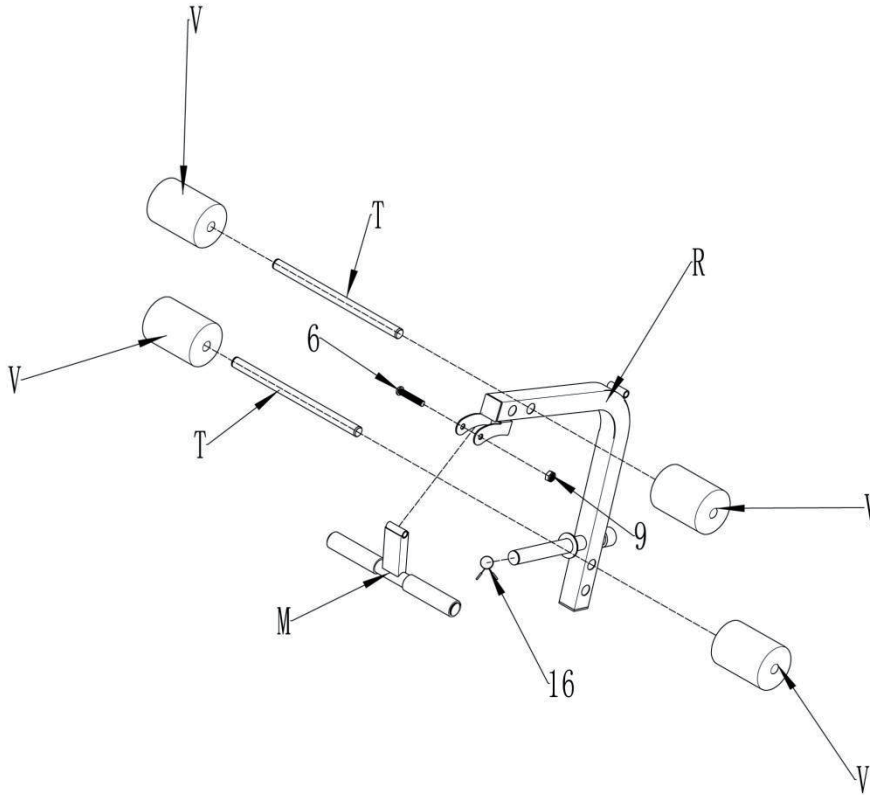

Step9: Attach the leg frame to the front support with a part 6 bolt and part 9 nut.

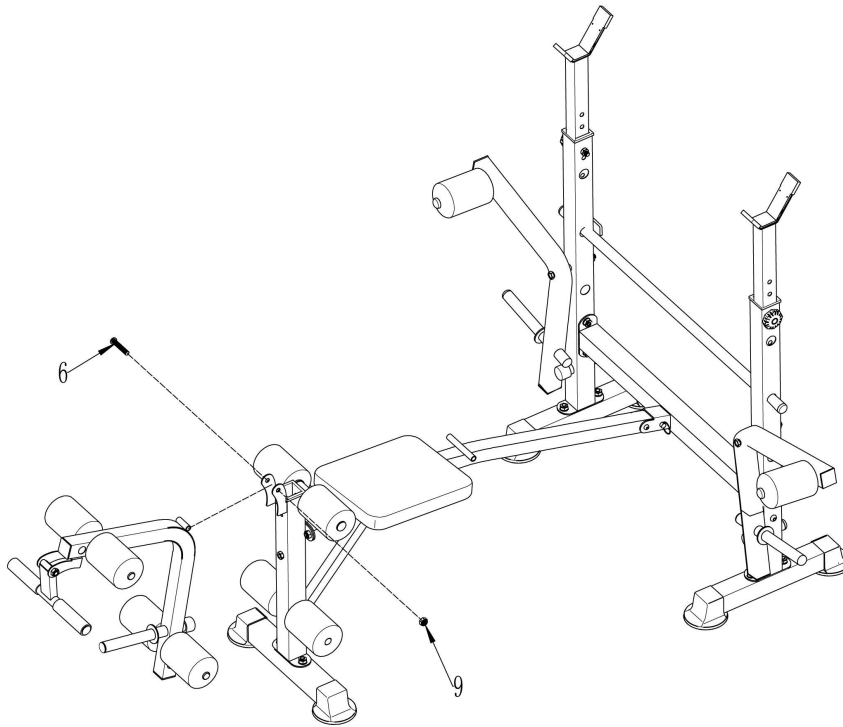

Step10: Attach two part W backrest frames to part A backrest pad with four part 10 bolts.

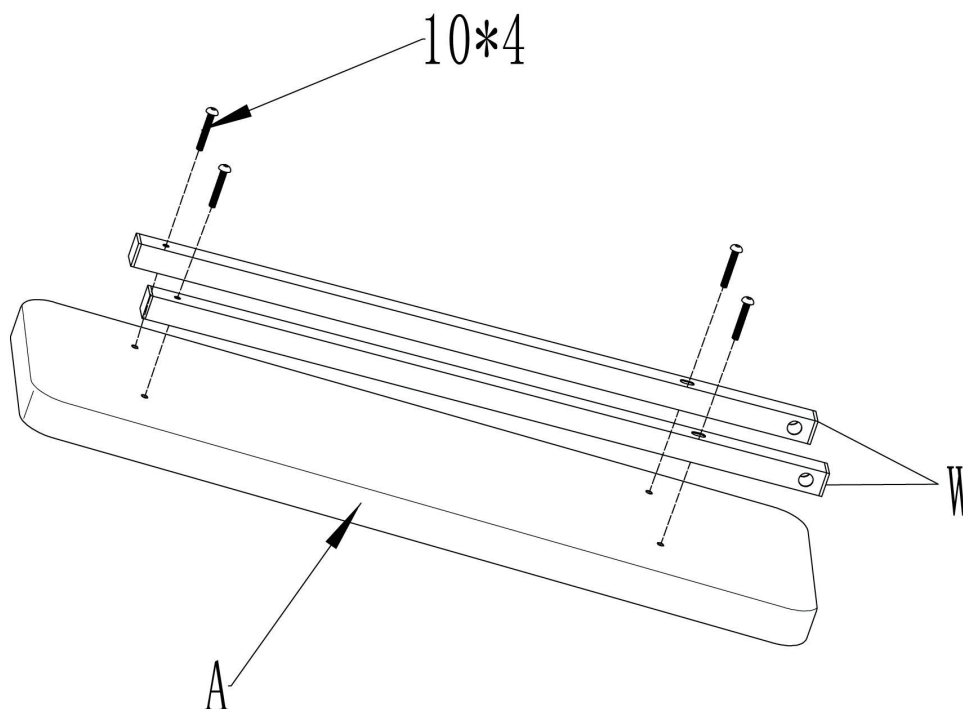

Step11: Attach part Q elbow support to part B elbow pad with two part 5 screws.

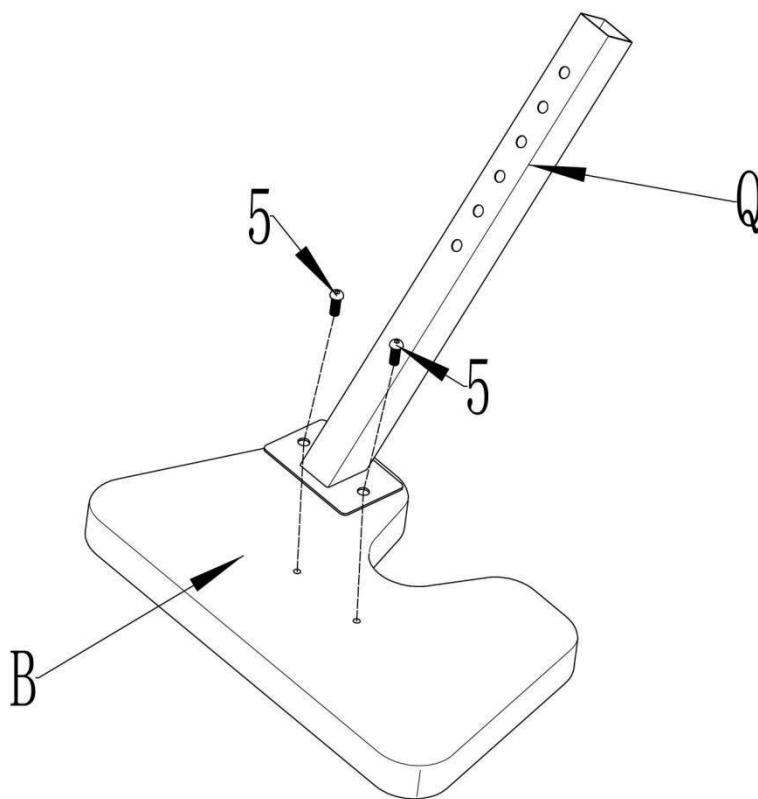

Step12: Attach the backrest to the main frame with a part 14 hex bolt and part 9 nut.

Insert the elbow pad and secure it with a part 3 knob.

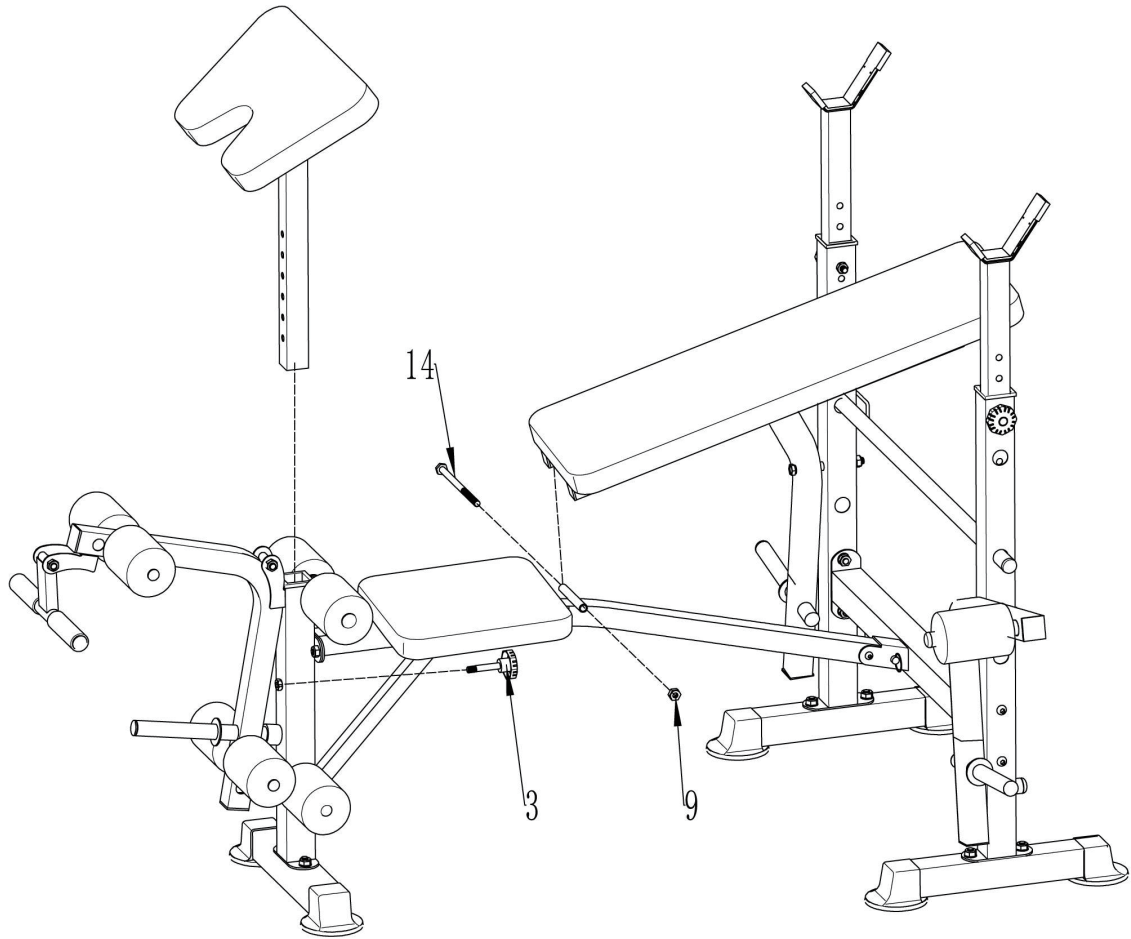

FEATURES



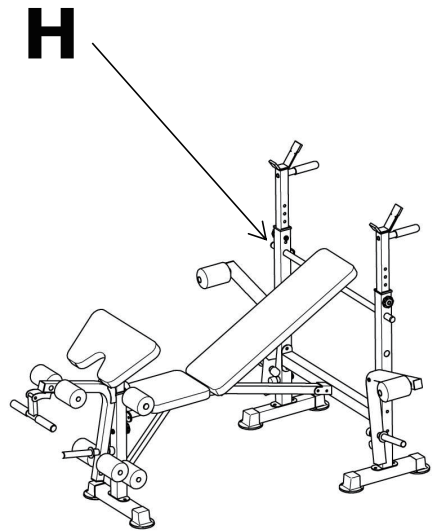
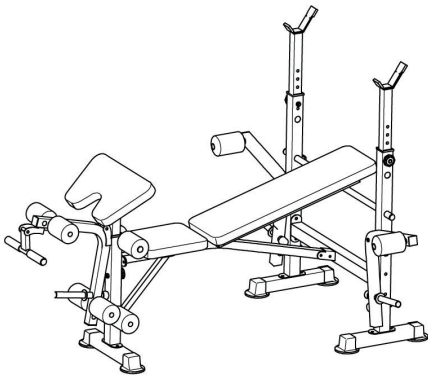
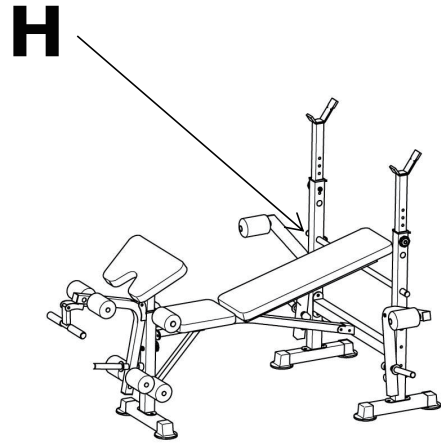
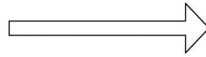
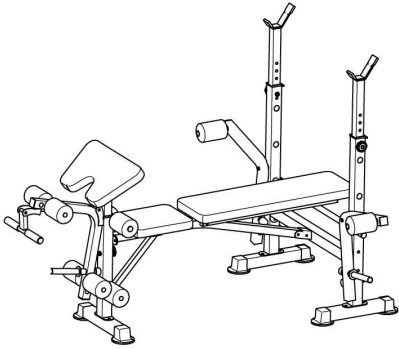







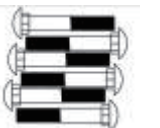
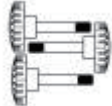





Flip up the long bench to transform into an incline bench and secure with part H angle control rod.





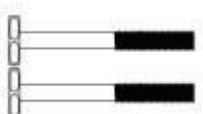

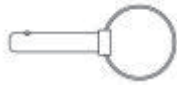









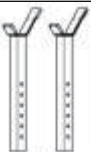





AVIS !

- Veuillez conserver ces instructions pour toute référence ultérieure.
- Veuillez ne pas dépasser les limites de poids de cet appareil.
- Poids maximum des utilisateurs : 330lbs / 150kgs.
- Ne vous tenez pas debout et n'utilisez aucune pièce de cet appareil comme un escabeau.
- Fixez fermement tous les boulons, vis et boutons avant utilisation.
- Serrez les vis sans serrer lors de l'assemblage initial. Ne serrez pas trop les vis tant que l'élément n'est pas complètement assemblé.
- Sachez que certaines pièces sont lourdes et ont des bords tranchants.
- Si des pièces sont manquantes, cassées, endommagées ou usées, cessez d'utiliser ce produit jusqu'à ce que les réparations soient effectuées et/ou que des pièces de rechange d'usine soient installées.

MATERIEL

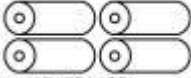
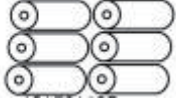
 <p>1. BOULON M10x65mm 4PCS</p>	 <p>2. BOULON DE CHARIOT M10x65mm 6PCS</p>	 <p>3. BOULON M10x55mm 3PCS</p>	 <p>4. BOULON M8x55mm 1PC</p>
 <p>5. VIS M8x20mm 6PCS</p>	 <p>6. BOULON M10x55mm 2PCS</p>	 <p>7. VIS M8x16mm 2PCS</p>	 <p>8. VIS M6x16mm 4PCS</p>
 <p>9. ÉCROU M10 15PCS</p>	 <p>10. BOULON M6x40mm 4PCS</p>	 <p>11. RONDELLE M10 10PCS</p>	 <p>12. RONDELLE M8 3PCS</p>
 <p>13. ÉCROU M8 3PCS</p>	 <p>14. BOULON HEXAGONAL M10x160mm 1PC</p>	 <p>15. BOULON HEXAGONAL M10x130mm 2PCS</p>	 <p>16. Φ25 PINCE 3PCS</p>
 <p>17. GOUPILLE M8x50mm 1PC</p>	 <p>18. CLÉ ALLEN N°6 1PC</p> <p>19. CLÉ ALLEN N°8 1PC</p>	 <p>20.13-17 CLÉ PLATE 2PCS</p>	

PIECE			
 A. COUSSIN DE DOSSIER 1PC	 B. COUSSINET DU COUDE 1PC	 C. COUSSINET DE SIÈGE 1PC	 D. CADRE PRINCIPAL 1PC
 E. J 3PCs	 F. CADRE LATÉRAL 2PCS	 G. CADRE LATÉRAL SUPÉRIEUR 2PCS	 H. TIGE DE COMMANDE D'ANGLE 1PC
 J. SUPPORT CARRÉ 1PC	 K. SUPPORT DE BRAS 2PCS	 L. BRAS 2PCS	 M. POIGNÉE 1PC
 N. SUPPORT FIXE 1PC	 P. SUPPORT AVANT 1PC	 Q. COUDIÈRE 1PC	 R. CADRE DE LA JAMBE 1PC
 S. φ22 SUPPORT ROND 1PC	 T. φ19 SUPPORT ROND 3PCS	 U. 17*73*130mm ROULEAU EN MOUSSE 4PCS	 V. 13*70*125mm ROULEAU EN MOUSSE 6PCS
 W. CADRE DU DOSSIER 2PCS			
NOTE : VEUILLEZ NOTER LA DIRECTION GAUCHE ET DROITE ENTRE LA PIÈCE F (CADRE LATÉRAL) ET LA PIÈCE K (SUPPORT DE BRAS) PENDANT L'INSTALLATION !			

ASSEMBLAGE DU PRODUIT

Étape 1 : Fixez les deux pieds latéraux de la pièce E aux deux cadres latéraux de la pièce F avec quatre boulons de carrosserie de la pièce 2, quatre rondelles de la pièce 11 et quatre écrous de la pièce 9.

Insérez deux cadres latéraux supérieurs de la pièce G et fixez-les avec deux boutons de la pièce 3.

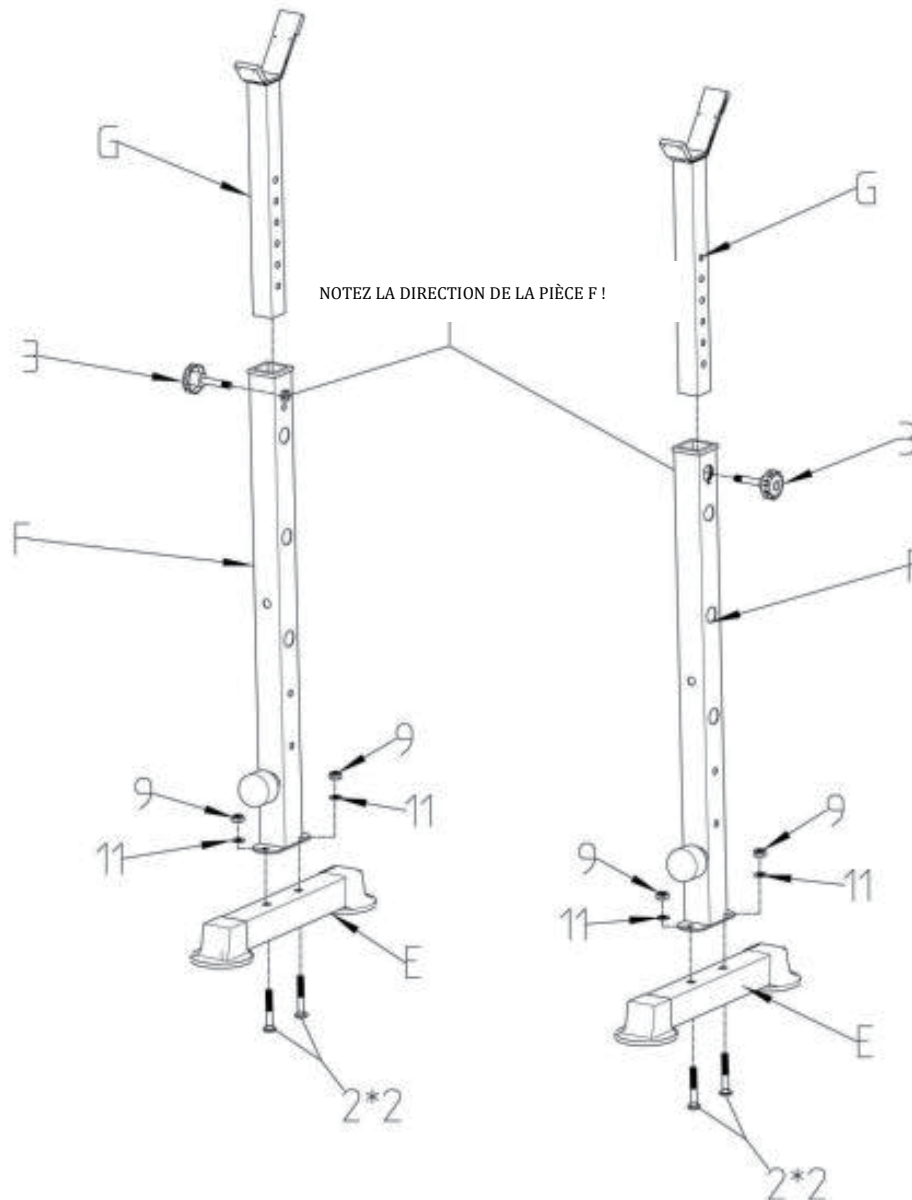

Étape 2 : Fixez le support carré de la pièce J aux cadres latéraux avec quatre boulons de la pièce 1, quatre rondelles de la pièce 11 et quatre écrous de la pièce 9. Insérez la tige de commande d'angle de la pièce H.

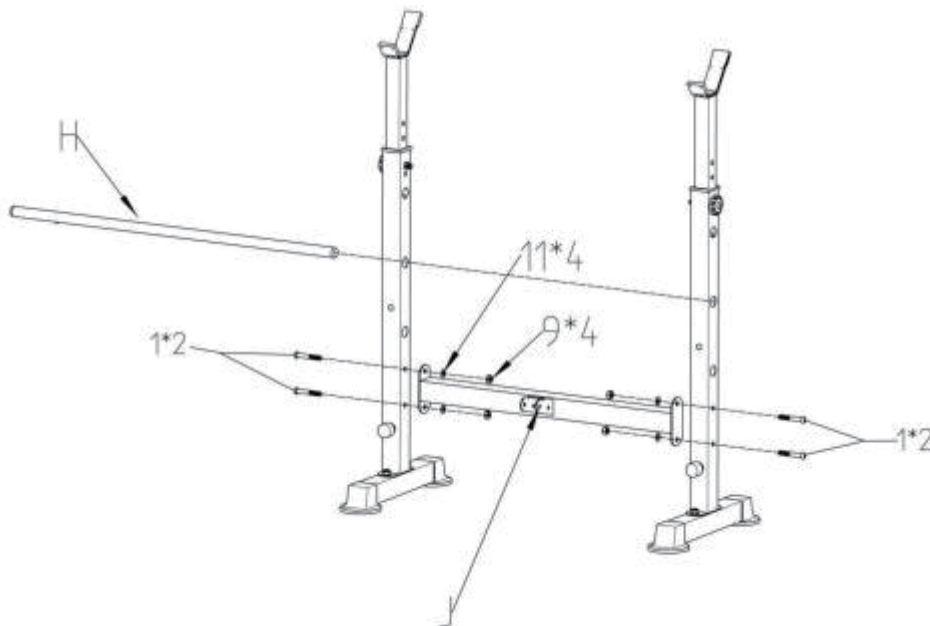

Étape 3 : Fixez les deux bras de la pièce L avec les deux rouleaux en mousse 17*73*130mm de la pièce U, aux deux supports des bras de la pièce K avec les deux vis de la pièce 5, les deux rondelles de la pièce 12 et les deux pinces de la pièce 16.

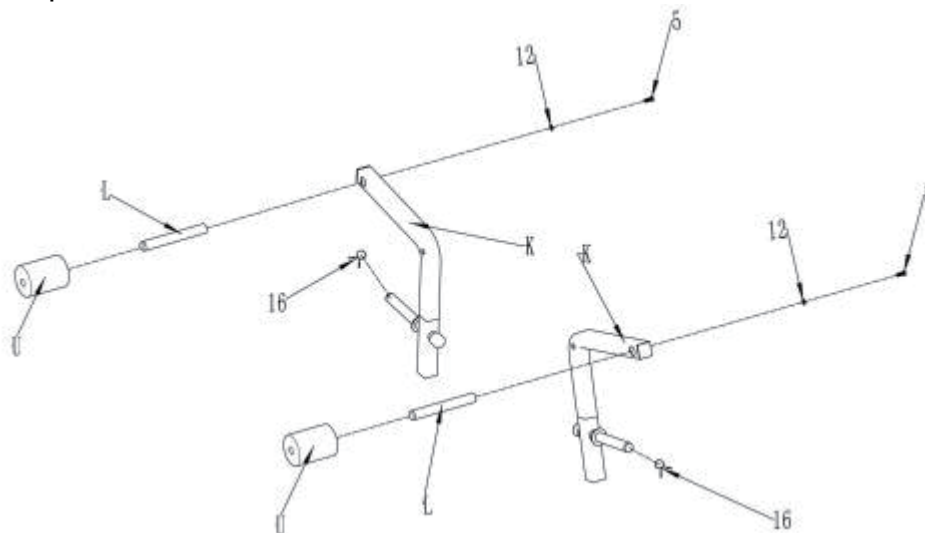

NOTEZ LA DIRECTION DE LA PIÈCE K !

Étape 4 : Fixez les supports de bras aux cadres latéraux avec deux boulons hexagonaux de la pièce 15 et deux écrous de la pièce 9.

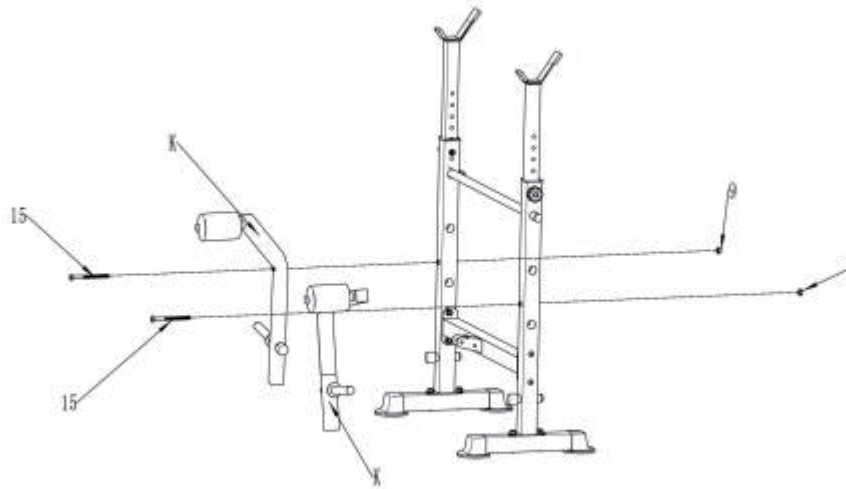

Étape 5 : Fixez le cadre principal de la pièce D au coussin de siège de la pièce C avec quatre vis de la pièce 8.

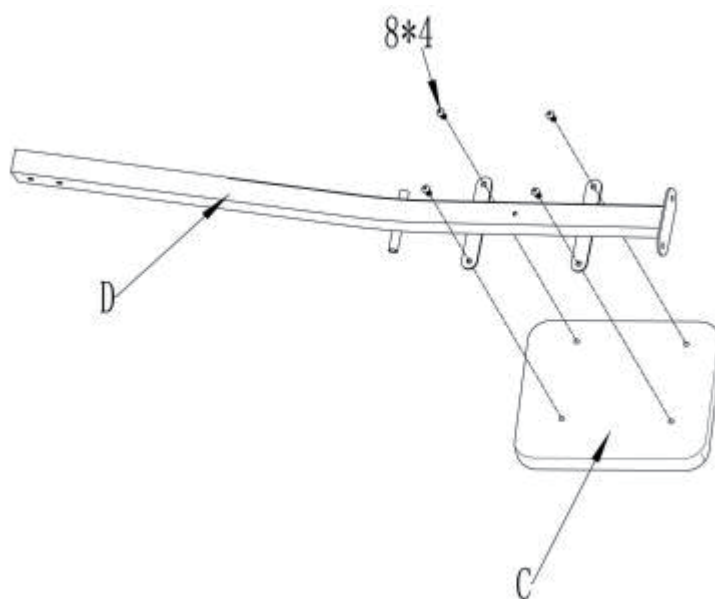

Étape 6 : Fixez le support avant de la pièce P au pied latéral de la pièce E avec deux boulons de carrosserie de la pièce 2, deux rondelles de la pièce 11 et deux écrous de la pièce 9.

Fixez le cadre principal aux cadres latéraux à l'aide d'un boulon de la pièce 4, d'une rondelle de la pièce 12 et d'un écrou de la pièce 13. Insérez la goupille de la pièce 17.

Fixez le support avant au cadre principal à l'aide de deux vis de la pièce 7 et de deux écrous de la pièce 13.

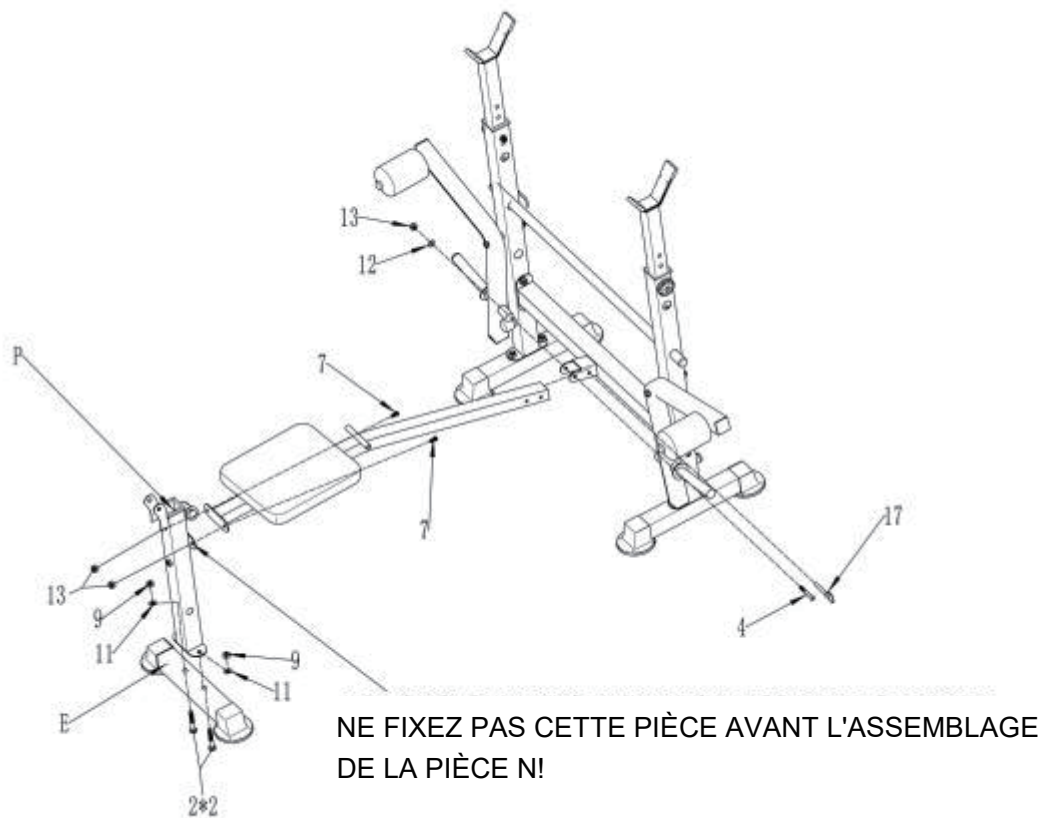

Étape 7 : Fixez le support fixe de la pièce N au cadre principal et au support avant avec deux vis de la pièce 5.

Insérer une pièce S $\Phi 22$ support rond avec deux pièces U $17*73*130$ mm rouleaux de mousse. Insérer une pièce T $\Phi 19$ support rond avec deux pièces V $13*70*125$ mm rouleaux en mousse.

FIXEZ CETTE PIÈCE APRÈS L'ASSEMBLAGE DE LA PIÈCE N!

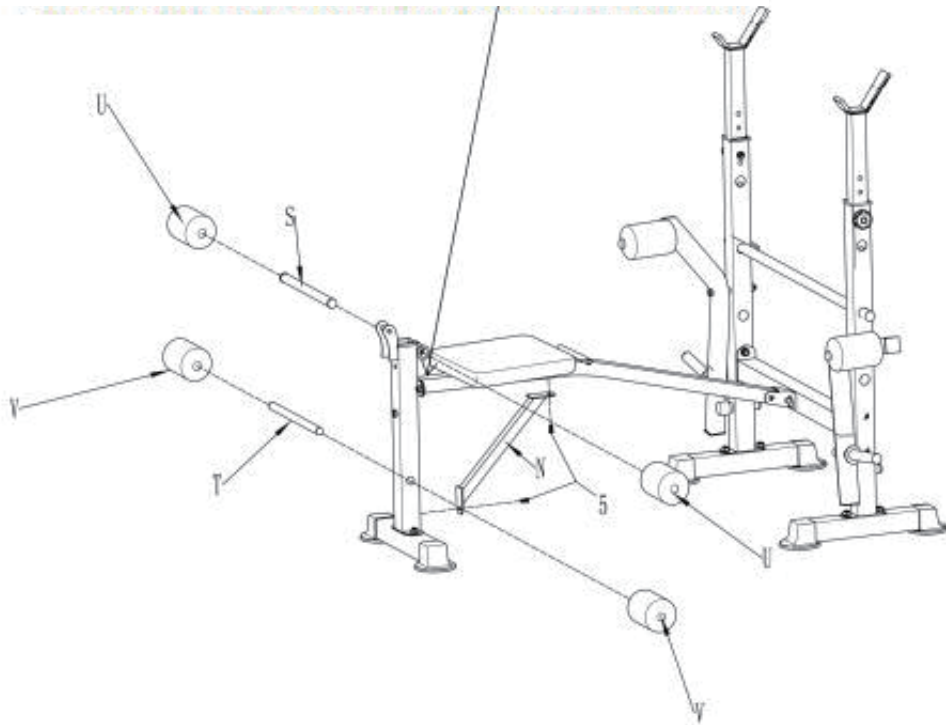

Étape 8 : Fixez la poignée de la pièce M au châssis de la pièce R avec un boulon de la pièce 6, un écrou de la pièce 9 et une pince de la pièce 16. Insérez deux pièces de supports ronds T Φ 19 avec quatre pièces de rouleaux de mousse V 13*70*125mm.

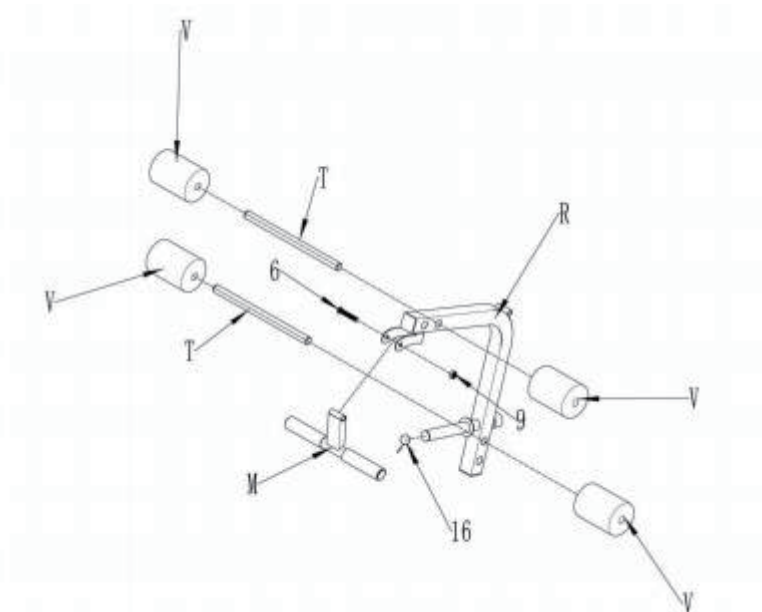

Étape 9 : Fixez le cadre de la jambe au support avant avec un boulon de la pièce 6 et un écrou de la pièce 9.

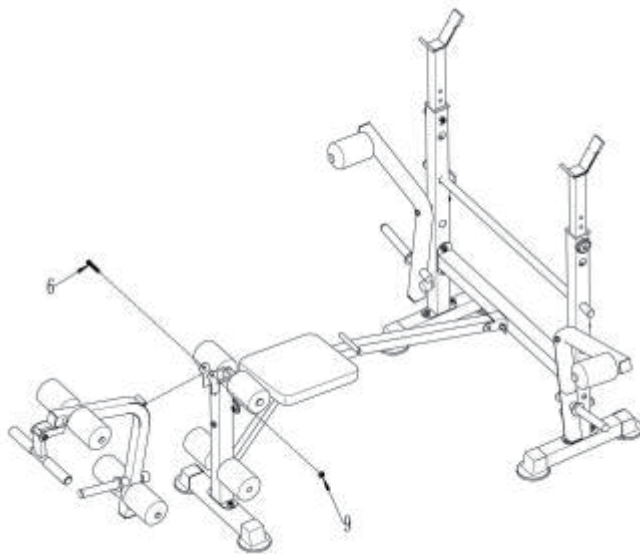

Étape 10 : Fixez les deux cadres de dossier de la pièce W au dossier de la pièce A avec quatre boulons de la pièce 10.

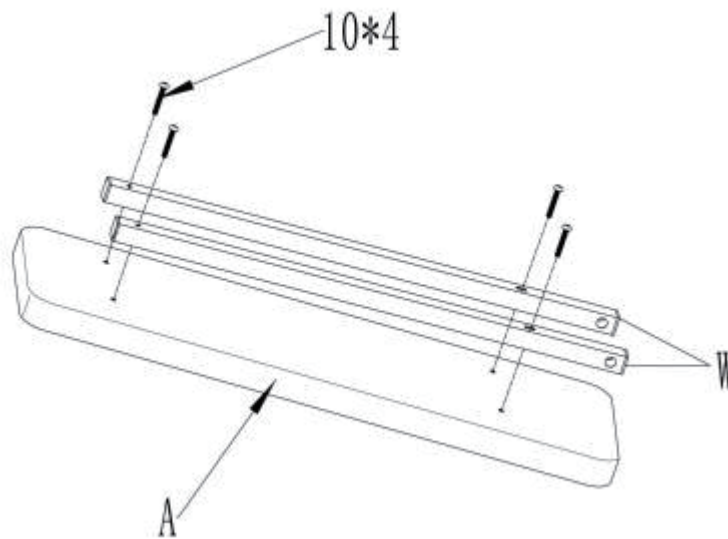

Étape 11 : Fixez la pièce Q du support de coude à la pièce B de la coudière avec deux vis de la pièce 5.

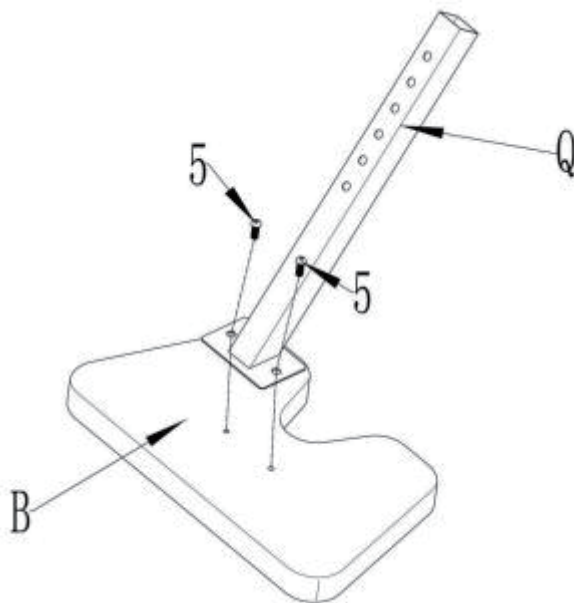

Étape 12 : Fixez le dossier au cadre principal à l'aide d'un boulon hexagonal de la pièce 14 et d'un écrou pièce 9.
Insérez la coudière et fixez-la avec un bouton de la pièce 3.

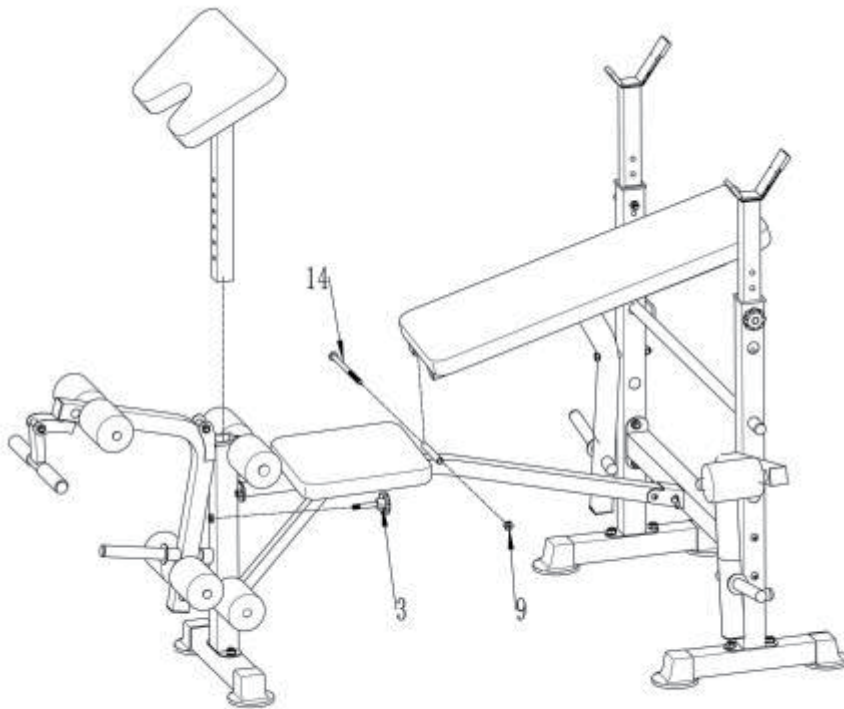

FONCTIONNALITES

Relevez le banc long pour le transformer en banc incliné et fixez-le avec la tige de commande d'angle de la pièce H.

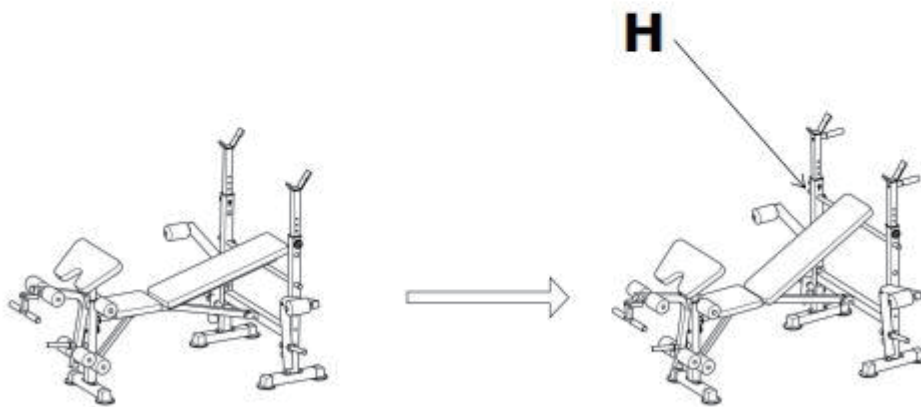
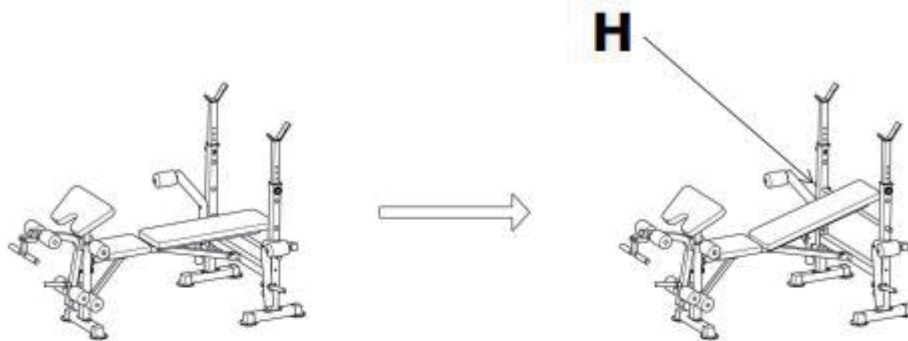

US

If you have any questions, please contact our customer care center.
Our contact details are below:

 001-877-644-9366

 customerservice@aosom.com

Imported by Aosom LLC
27150 SW Kinsman Rd Wilsonville, OR 97070 USA
MADE IN CHINA

CA

If you have any questions, please contact our customer care center.
Our contact details are below:

Si vous avez la moindre question, veuillez contacter notre centre d'assistance à la clientèle.
Nos coordonnées sont les suivantes:

 416-792-6088

 customerservice@aosom.ca

Imported by Aosom Canada Inc.
7270 Woodbine Avenue, Unit 307, Markham, Ontario Canada L3R 4B9
MADE IN CHINA

Importé par Aosom Canada Inc.
7270 Woodbine Avenue, unité 307, Markham, Ontario Canada L3R 4B9
Fabriqué en Chine