



INfaa018V02_UK
370-068

CHILDREN' S ELECTRIC MOTORCYCLE



Owner' s Manual with Assembly Instructions

Styles and colo(u)rs may vary.
Made in China.

The owner' s manual contains important safety information as well as assembly, use and maintenance instructions.

The Ride-on Car must be assembled by an adult who has read and understands the instructions in this manual.

Keep the package away from children and dispose of properly before use.

Keep this manual for future reference.

On the purchase of your new Ride-On.

This ride-on will provide your child with many miles of riding of enjoyment. To help assure you and your rider a safe ride we ask you to please read this manual carefully, and keep it for future reference.

Follow the recommendations in this manual, they are designed to improve the safety and operation of your ride-on car and it's rider.

SPECIFICATIONS:

Battery	6V4AH*1
Charger	6V500mA

Suitable age:	37-96 months
Load Capacity:	Under 30kg
Speed:	3km/h
Size of car:	106 x 64 x 51 CM
Power way:	Charging type
Charge time:	8-12 hours

Parts List | 2

PART NO.	PART NAME	Q'ty (pcs)		REMARKS
1	Vehicle body	1		
2	Seat	1		
3	Front fork	1		
4	Face guard	1		
5	Front fender	1		
6	Absorber tube	2		
7	Side wheel	1		
8	Front wheel	1		
9	Wheel cover	2		
10	Brake	2		
11	Foot plate	2		
12	Foot plate axle	1		
13	Front axle	1		
14	Ø4x12 screw	6		
15	Ø10 lock nut	5		
16	Ø10 washer	2		
17	Ø8 lock nut	2		
18	M10X190 bolt	1		
19	M5X16 machine screw	1		
20	Socket spanner	2		
21	Charger	1		
22	Spanner	1		

Parts Diagram | 3

HINT: Some parts shown are assembled on both sides of vehicle

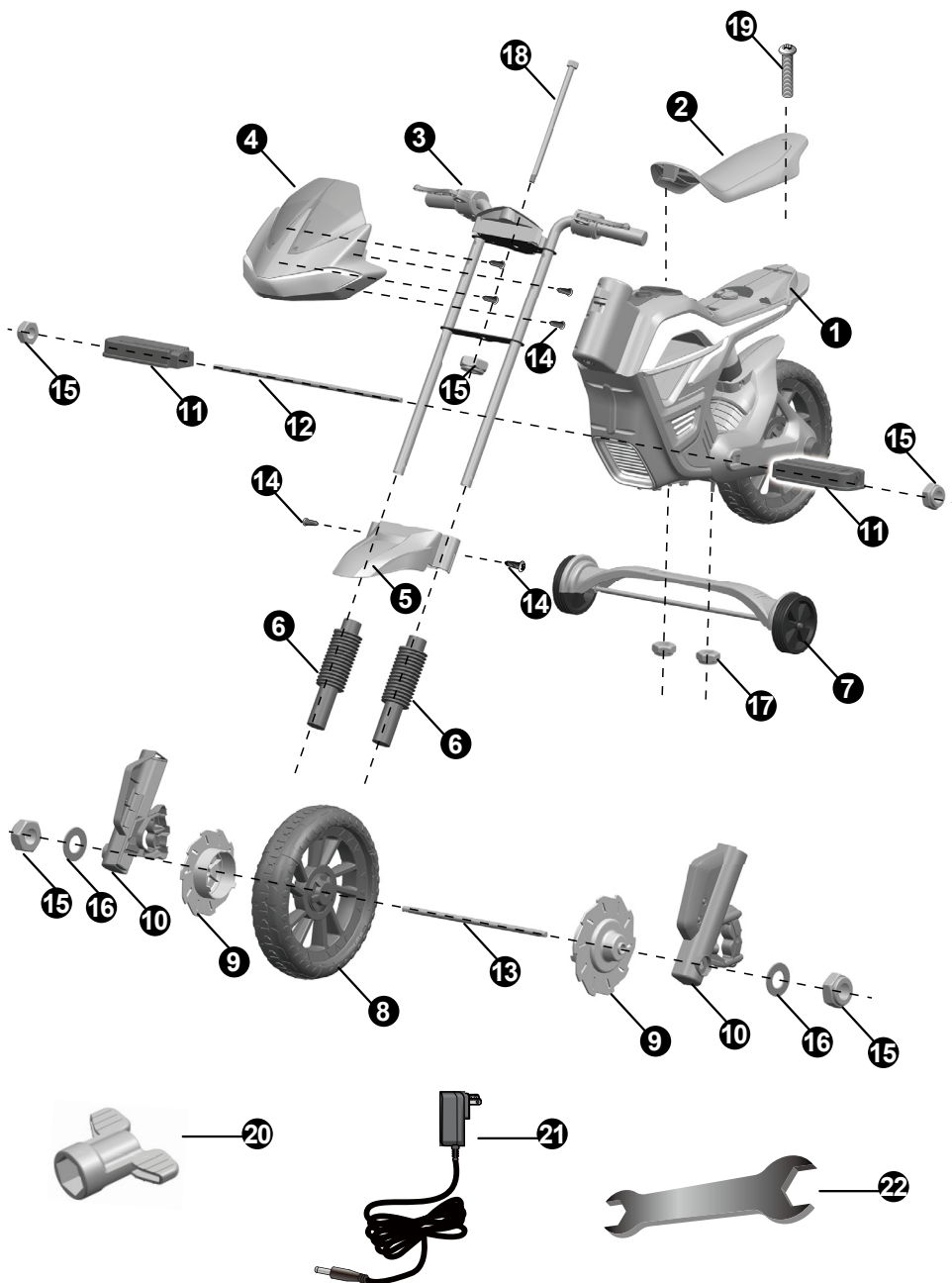

 **WARNING!**

- **CHOKING HAZARD** - Small parts. Not suitable for children under 36 months. The product contains small parts, keep children away when assembling.
 - **ADULT ASSEMBLY REQUIRED.**
 - Always remove protective material and poly bags and dispose before assembly.
-
- Make sure that the power switch is **turned “OFF”** before assembling the ride-on.
 - Before first time use, charge the battery for at least 4 to 6 hours.
 - Assembly tools required:



Screwdriver
(not included)



Spanner

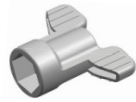

Socket spanner

**BATTERY INFORMATION**

- Non-rechargeable batteries are not to be recharged.
- Rechargeable batteries are to be removed from the toy before being charged.
- Rechargeable batteries are only to be charged under adult supervision.
- Different types of batteries or new and used batteries are not to be mixed.
- Batteries are to be inserted with the correct polarity.
- Exhausted batteries are to be removed from the toy.
- The supply terminals are not to be short-circuited.

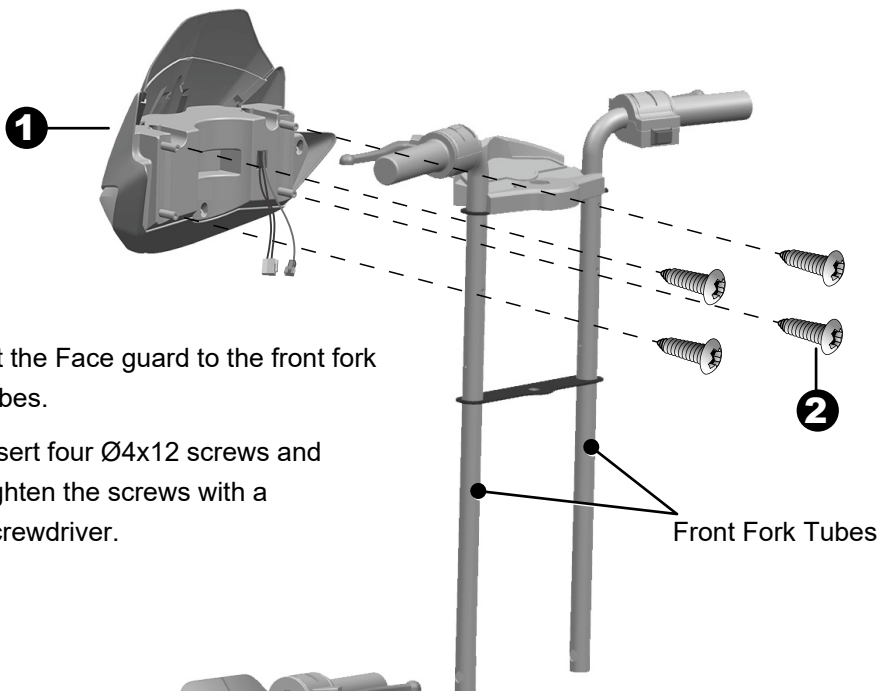

1. Fit the Face guard to the front fork tubes.

2. Insert four $\text{\O}4\times 12$ screws and tighten the screws with a screwdriver.

Front Fork Tubes

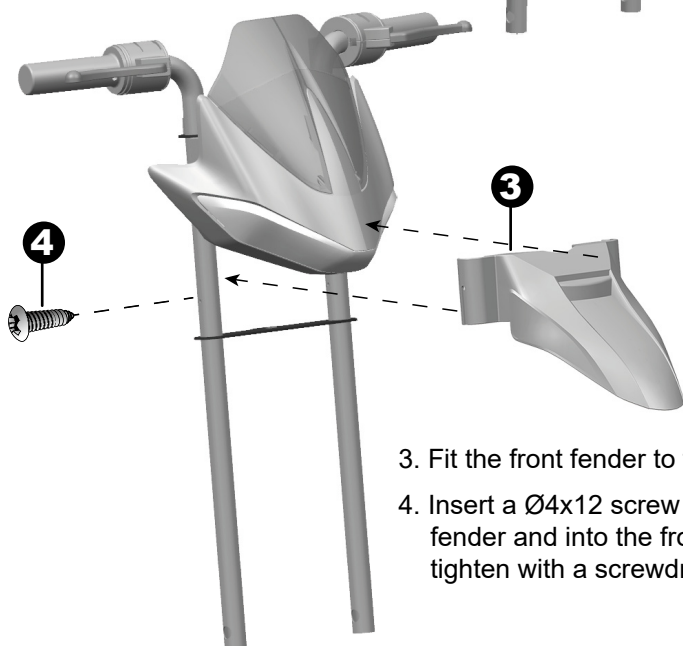

3. Fit the front fender to the front fork.

4. Insert a $\text{\O}4\times 12$ screw through the front fender and into the front fork tube, and tighten with a screwdriver on each side.

1. Slide the absorber tubes onto the front fork tubes.
2. Slide the brakes to the front fork tubes.

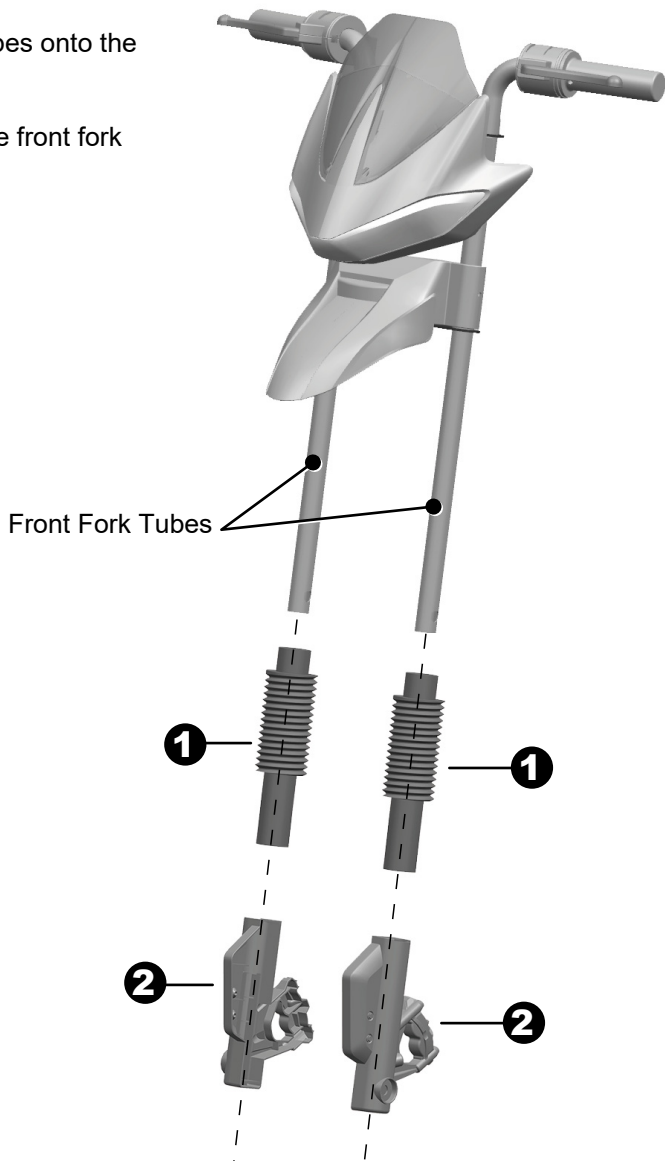

Attach the Front Wheel | 7

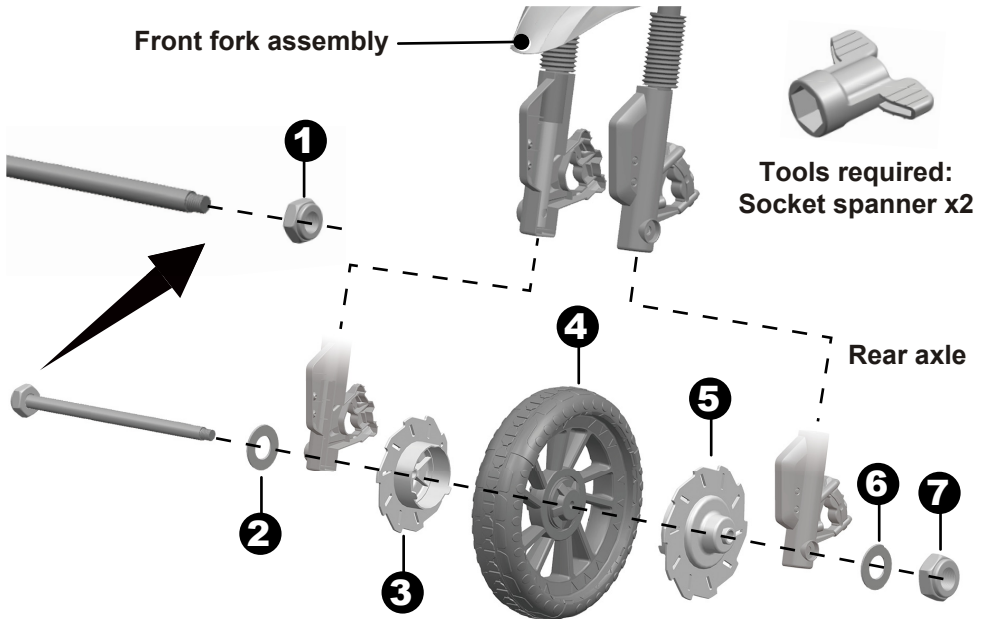

1. Tighten a **Ø10 lock nut** to the end of the front axle.
2. Slide a **Ø10 washer** onto the front axle.
3. Insert the front axle through the hole on the front fork, slide a **wheel cover** to the front axle.
4. Slide a **front wheel** onto the front axle.
5. Slide a **wheel cover** onto the front axle.
6. Pushing the front axle until it pass through the hole on the other side of the front fork. Slide a **Ø10 washer** to the front axle.
7. Tighten a **Ø10 lock nut** onto the end of the front axle with a socket spanner.

HINT: An extra socket spanner has been provided to hold the Lock Nut on the other side of the front axle while tightening the Lock Nut on the other side.

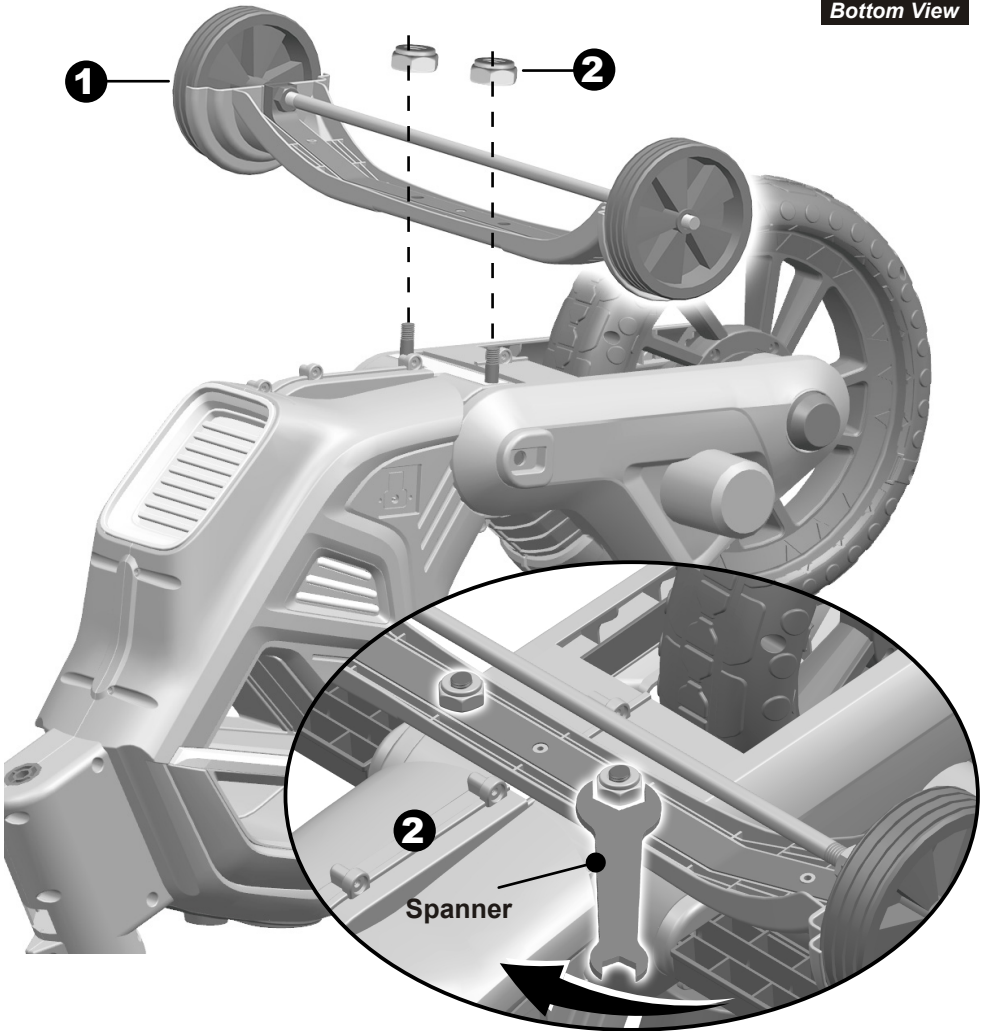

Turn the vehicle body downside up.

1. Fit the side wheel to the vehicle body.
2. Tighten two **Ø8 lock nuts** to secure it with a spanner.

1. Tighten a **Ø10 lock nut** onto one end of the foot plate axle with a socket spanner.
2. Slide a **foot plate** (larger end out) onto the foot plate axle. Insert the foot plate axle into the hole on the vehicle body, ensure the square end of the foot plate inserted into the groove on the vehicle body. Continue pushing the foot plate axle still it passes through the vehicle body.

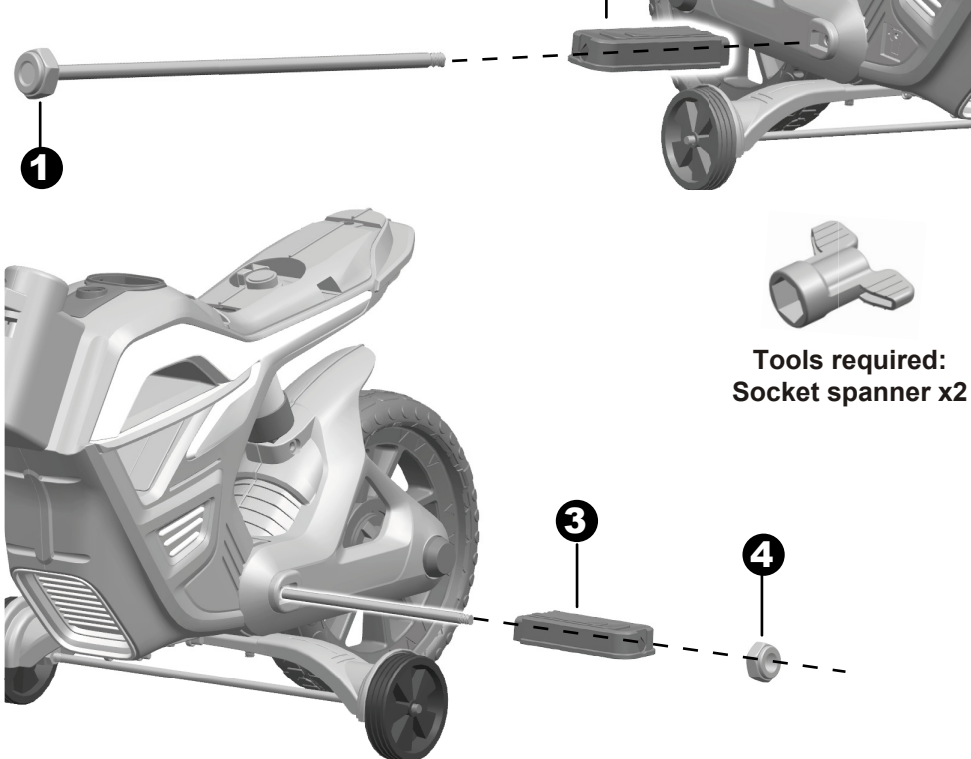

3. Slide a **foot plate** onto the foot plate axle from the other side of vehicle body.
4. Tighten a **Ø10 lock nut** to the end of the foot plate axle with a socket spanner.

HINT: An extra socket spanner has been provided to hold the Lock Nut on the other side of the front axle while tightening the Lock Nut on the other side.

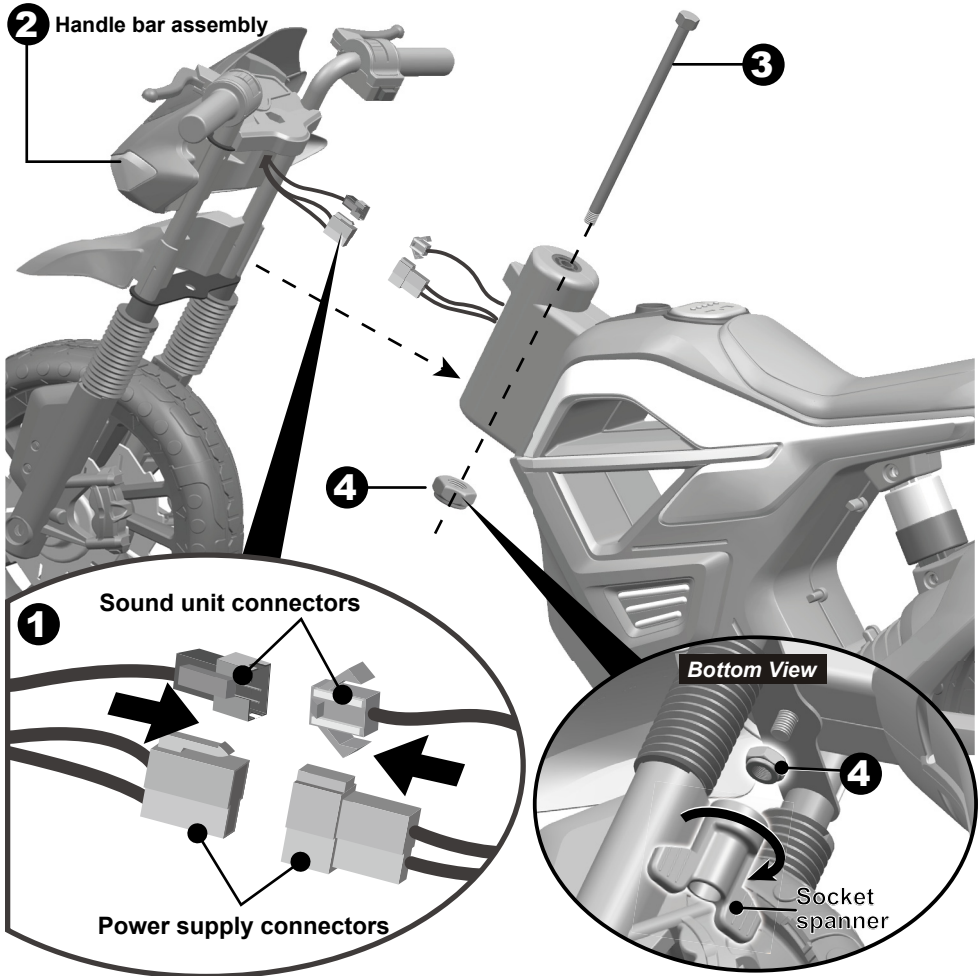

1. Plug the sound unit connectors into each other. Plug the power supply connectors into each other.
2. Fit the handle bar assembly to the vehicle body.
3. Insert the M10x190 bolt through the hole on handbar assembly, the hole on vehicle body, and out through the hole on the bottom of handbar assembly.
4. Tighten a $\varnothing 10$ lock nut to the end of the bolt with a socket spanner.

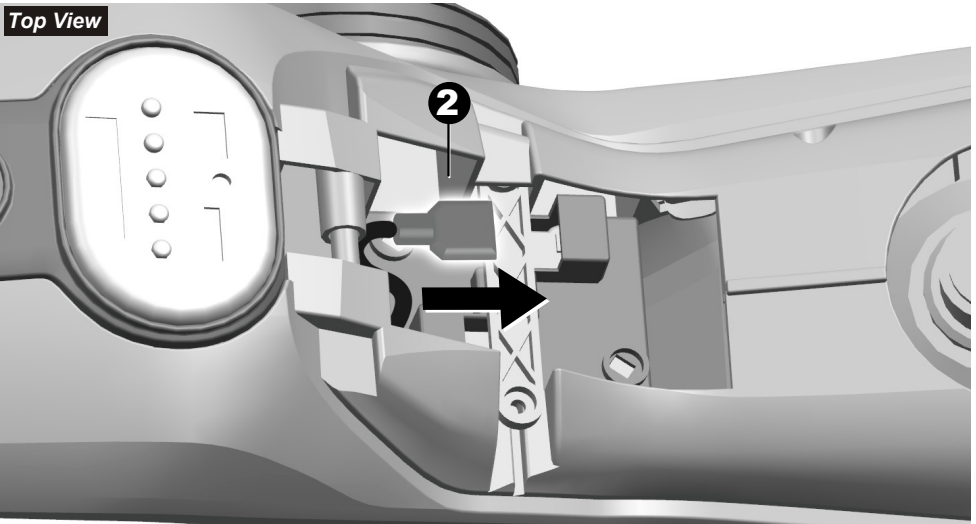
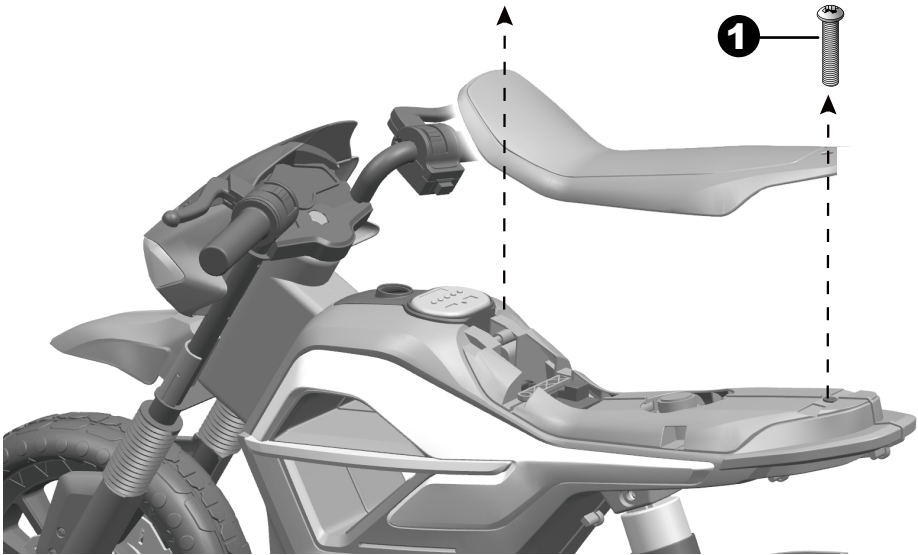

1. Remove the screw on the top of the seat with a screwdriver, and lift to remove it.
2. Plug the red wire connector on the vehicle body into the terminal on battery. Replace the seat.

WARNING!

PREVENT INJURIES AND DEATHS:

- **NEVER LEAVE CHILD UNATTENDED. DIRECT ADULT SUPERVISION IS REQUIRED.** Always keep child in view when child is in vehicle.
- This toy should be used with caution since skill is required to avoid falls or collisions causing injury to the user or third parties.
- Protective equipment should be worn.
- Never use in roadways, near cars, on or near steep inclines or steps, swimming pools or other bodies of water.
- Always wear shoes.
- Always sit on the seat.
- Not to be used in traffic.
- This toy is unsuitable for children under 36 months due to its maximum speed; Maximum user weight is 30kg.
- This toy has no brake.

Rules for Safe Riding

- Keep Children within Safe Riding Areas:
 - Never use in roadway, near motor vehicles, on lawn space, on or near steep inclines or steps, swimming pools or other bodies of water;
- Use the toy only on flat surfaces. Such as inside your house, garden or playground.
- Never use in the dark. A child could encounter unexpected obstacles and have an accident. Operate the vehicle only in the daytime or a well-lit area.
- It is prohibited to change the circuit or add other electric parts
- Inspect wires and connections of the vehicle periodically.
- Do not let any child touch the wheels or be near them when the car is moving .



Use the vehicle on generally level ground ONLY!

DO NOT Use the vehicle on Lawn space!

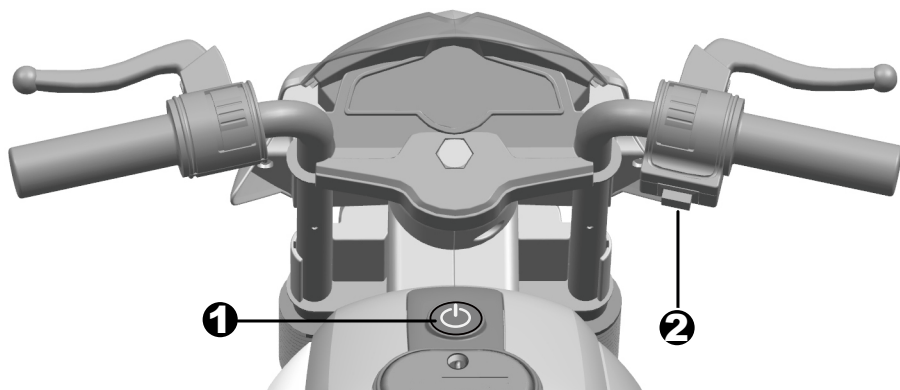

1. **Power Switch:** Turns the vehicle on and off.
2. **Forward button:**
 - To move the product forward, press the button down.
 - To brake or slow down, release pressure from the button.

PLAYER (IF EQUIPPED)

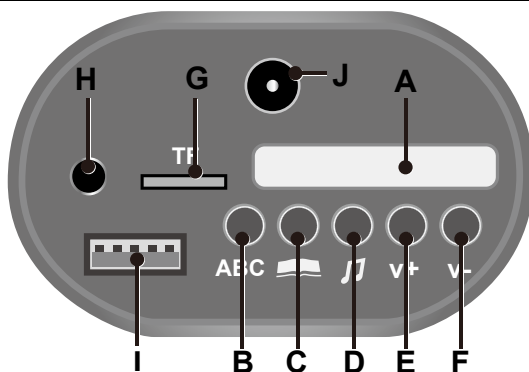

- A. **Digital voltmeter:** Check the power remaining of your battery, refer to page 15.
- B. **English learning mode**
- C. **Storytelling mode**
- D. **Nursery rhyme singing mode**
- E. **Increase volume**
- F. **Decrease volume**
- G. **TF (Micro SD) card slot:** Allow the audio from your TF card to be played through the vehicle speakers.
- H. **Device input 1:** Allow the audio from your portable music player or phone to be played through the vehicle speakers.
- I. **Device input 2:** Allow the audio from your portable device to be played through the vehicle speakers.
- J. **Charge input socket.**

ONLY AN ADULT CAN CHARGE AND RECHARGE THE BATTERY!



WARNING!

• **PREVENT FIRE AND ELECTRIC SHOCK:**

- Use the only rechargeable battery and charger supplied with your vehicle. NEVER substitute the battery or the charger with another brand. Using another battery or charger may cause a fire or explosion.
- Do not use the battery or charger for any other product. Overheating, fire or explosion could occur.
- NEVER modify the electric circuit system. Tampering with the electric system may cause a shock, fire or explosion or may permanently damage the system.
- Do not allow direct contact between battery terminals. Fire or explosion can occur.
- Do not allow any type of liquid on the battery or its components.
- Explosive gasses are created during charging. Do not charge near heat or flammable materials. Charge the battery in a well-ventilated area ONLY.
- NEVER pick up the battery by the wires or charger. Damage can occur to the battery and may cause a fire. Pick up the battery by the case ONLY.
- Charge the battery in a dry area ONLY.
- Battery posts, terminals and related accessories contain lead and lead compounds, chemicals known to cause cancer and reproductive harm. **Wash hands after handling.**
- Do not open the battery. Battery contains lead acid and other materials that are toxic and corrosive.
- Do not open the charger. Exposed wiring and circuitry inside case may cause electric shock.
- Only adults may handle or charge the battery. NEVER allow child to handle or charge the battery. Battery is heavy and contains lead acid (electrolyte).
- Do not drop the battery. Permanent damage to the battery could occur or cause serious injury.
- Before charging the battery, check for wear or damage to the battery, charger, its supply cord and the connectors. DO NOT charge the battery if any damage to parts has occurred.
- Do not allow the battery to drain completely. Recharge the battery after each use or once a month if not used regularly.
- Do not charge battery upside down.
- Always secure the battery with the bracket. Battery can fall out and injure a child if vehicle tips over.

- The POWER SWITCH must be turned in **OFF** position when charging.
- Before the first use, you should charge the battery for 4-6 hours. Do not recharge the battery for more than 10 hours to avoid overheating the charger.
- When the vehicle begins to run slowly, recharge the battery.
- After each use or once a month minimum recharge time as 8 to 12 hours, less than 20 hours at most.

Charging | 15

- If your ride-on with a **Digital voltmeter(IF EQUIPPED)**, the magnitude of voltage will tell you how much power is remaining in the battery when you must recharge the battery. Make sure the vehicle is stop!

BATTERY	MAGNITUDE OF VOLTAGE	BATTERY STATE
6V4Ahx1	≥ 6.6	The battery is full.
	6.5~6.3	The vehicle can work normally.
	≤ 6.2	The battery needs to be charge.

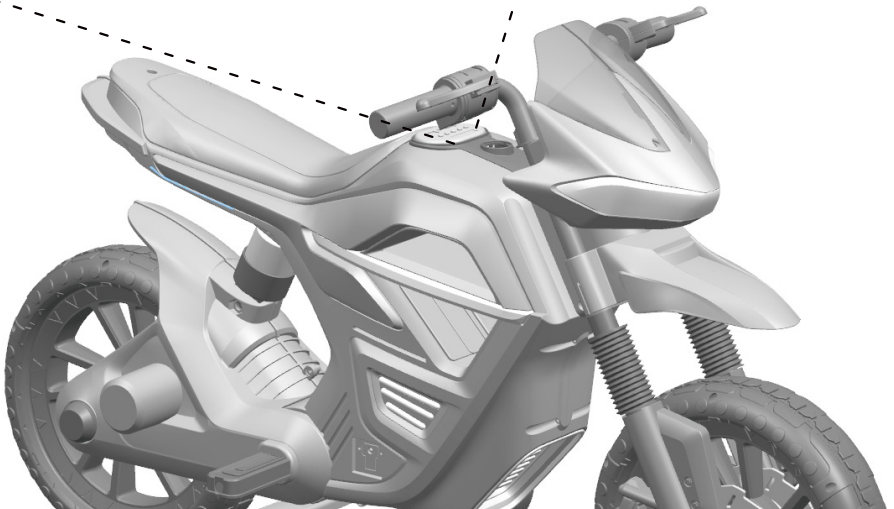
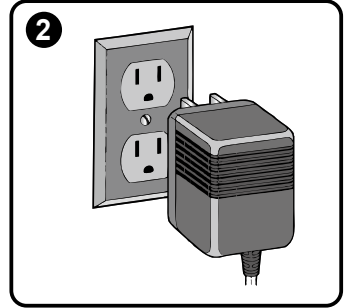
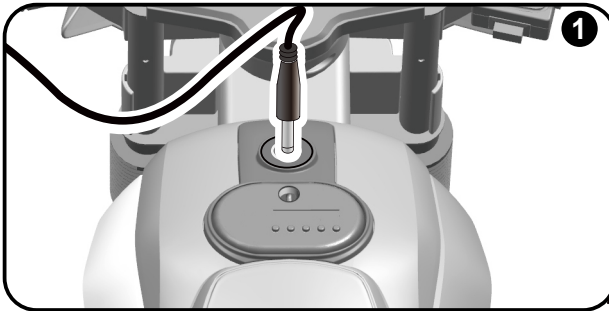

1. Plug the charger port into the input socket. (the socket is on the MP3 player)
2. Plug the charger plug into a wall outlet. The battery will begin charging.



WARNING!

This product with **Charging Protection**: when charging, all functions will be cut off! Only an adult can charge and recharge the battery!

The battery features a thermal fuse with a reset fuse that will automatically trip and cut all power to the vehicle if the motor, electric system or battery is overloaded. The fuse will reset and power will be restored after the unit is turned OFF for 20 seconds and then turned ON again. If the thermal fuse trips repeatedly during normal use, the vehicle may need repair. **Contact your distributor please.**

To avoid losing power, follow these guidelines:

- Do not overload the vehicle.
- Do not tow anything behind the vehicle.
- Do not drive up steep slopes.
- Do not drive into fixed objects, which may cause the wheels to spin, causing the motor to overheat.
- Do not drive in very hot weather, components may overheat.
- Do not allow water or other liquids to come in contact with the battery or other electric components.
- Do not tamper with the electric system. Doing so may create a short, causing the fuse to trip.

Battery Replacement and Disposal



The battery will eventually lose the ability to hold a charge. Depending on the amount of use, and varying conditions, the battery should operate for one to three years. Follow these steps to replace and dispose the battery:

1. Remove the car seat.
2. Disconnect the battery connectors.
3. Remove the battery bracket.
4. Remove the battery cover.
5. Carefully lift the battery.
 - Depending on the condition of the battery (i.e.: leakage) you may want to wear protective gloves before removal.
 - Do not lift the battery by its connectors or cables.
6. Place the dead battery in a plastic bag.

Important! Recycle the dead battery responsibly. The battery contains lead acid (electrolyte) and must be disposed of properly and legally. It is illegal in most areas to incinerate lead acid batteries or dispose of them in landfills. Take it to a federal or state-approved lead acid battery recycler, such as local automotive battery retailer. Do not throw the battery away with your regular household waste!

7. Replace the battery and reconnect the connectors.
8. Replace the metal battery bracket.
9. Replace the seat.

Problem	Possible Cause	Solution
Vehicle does not run	Battery low on power	Recharge battery.
	Thermal fuse has tripped	Reset fuse, see <Fuse>
	Battery connector or wires are loose	Check that the battery connectors are firmly plugged into each other. If wires are loose around the motor contact your distributor please.
	Battery is dead	Replace battery, contact your distributor please.
	Electrical system is damaged	Contact your distributor please.
	Motor is damaged	Contact your distributor please.
Vehicle does not run very long	Battery is under charged	Check that the battery connectors are firmly plugged into each other when recharging
	Battery is old	Replace battery, contact your distributor please.
Vehicle runs sluggishly	Battery low on power	Recharge battery, contact your distributor please.
	Battery is old	Replace battery, contact your distributor please.
	Vehicle is overload	Reduce weight on vehicle. Maximum user weight is 30kg.
	Vehicle is being used in harsh conditions	Avoid using vehicle in harsh conditions ,see <Safety>.
Vehicle needs a push to go forward	Poor contact of wires or connectors	Check that the battery connectors are firmly plugged into each other. If wires are loose around the motor, contact your distributor please.
	"Dead Spot" on motor	A dead spot means the electric power is not being delivered to the terminal connection and the vehicle needs repair. Contact your distributor please.
Difficult shifting from forward to reverse or vice-versa	Attempting to shift while the vehicle is motion	Completely stop the vehicle and shift, see <Use Your Ride-On>
Loud grinding or clicking noises coming from motor or gear box	Motor or gears are damaged	Contact your distributor please.
Battery will not recharge	Battery connector or adapter connector is loose	Check that the battery connectors are firmly plugged into each other.
	Charger not plugged in	Check that the battery charger is plugged into a working wall outlet.
	Charger is not working	Contact your distributor please.
Charger feels warm when recharging	This is normal and not a cause for concern	

Completely read through this manual and the troubleshooting guide table before calling. If you still need help resolving the problem **Contact your distributor please.**

- It is parents' responsibility to check main parts of the toy before using, Must regularly examine for potential hazard, such as the battery, charge, cable or cord, plug, screws are fastening enclosure of other parts and that in the event of such damage, the toy must not be used until that damage had been properly removed.
- Make sure the plastic parts of the vehicle are not cracked or broken.
- Occasionally use a lightweight oil to lubricate moving parts such as wheels.
- Park the vehicle indoors or cover it with a tarp to protect it from wet weather.
- Keep the vehicle away from sources of heat, such as stoves and heaters. Plastic parts may melt.
- Recharge the battery after each use. Only an adult can handle the battery. Recharge the battery at least once a month when the vehicle Raider is not being used.
- Do not wash the vehicle with a hose. Do not wash the vehicle with soap and water. Do not drive the vehicle in rainy or snowy weather. Water will damage the motor, electric system and battery.
- Clean the vehicle with a soft, dry cloth. To restore shine to plastic parts, use a non-wax furniture polish. Do not use car wax. Do not use abrasive cleaners.
- Do not drive the vehicle in loose dirt, sand or fine gravel which could damage the moving parts, motors or the electric system.
- When not using, all the electrical source should be turn off. Turn off the power switch and disconnect the battery connection.

Our products are suitable for
ASTM F963; GB6675; EN71 and EN62115 standard.