



VELOCITYONE™ RACE

PRODUCT GUIDE

IMPORTANT: READ BEFORE USING

PLATFORM COMPATIBILITY

- Xbox Series X|S & Xbox One
- Windows 10/11

CONTENTS & PRODUCT TOUR

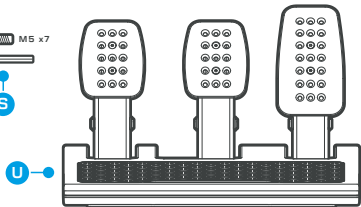
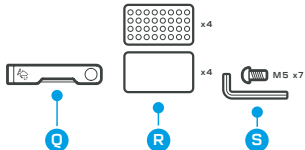
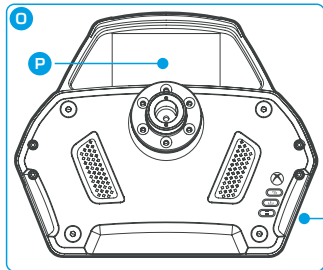
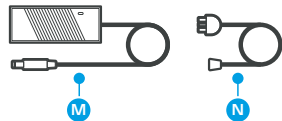
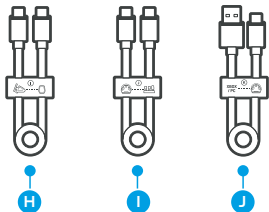
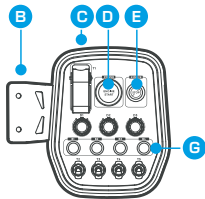
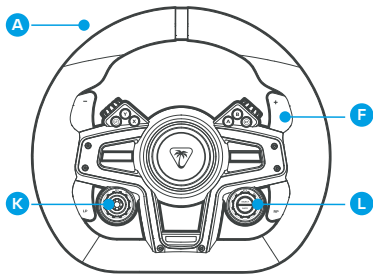

- A** Race Wheel Module
- B** VCU Bracket
- C** VelocityOne™ Control Unit (VCU)
- D** Power Button – Press [2s] = Power on, Press [2s] = Power off
- E** K:Drive™ Stop – Pressing this button will instantly cut power to the entire VelocityOne Race system.
- F** Magnetic Gear Shifters
- G** Programmable dials and switches
- H** VCU Cable
- I** Pedal Cable
- J** Xbox/PC Cable
- K** DPAD
- L** RMD Controls
- M** Power Supply Unit – Use only with VelocityOne Race.
- N** Power Supply Cable x3
- O** Race Wheelbase
- P** Race Management Display (RMD)
- Q** Adjustment Tool
- R** Pedal Stability Pads
- S** Sim Frame Screws M5 x7 (with tool)
- T** Headset Port
- U** Pedal Unit

CONTROL DESCRIPTION – WHEEL FRONT

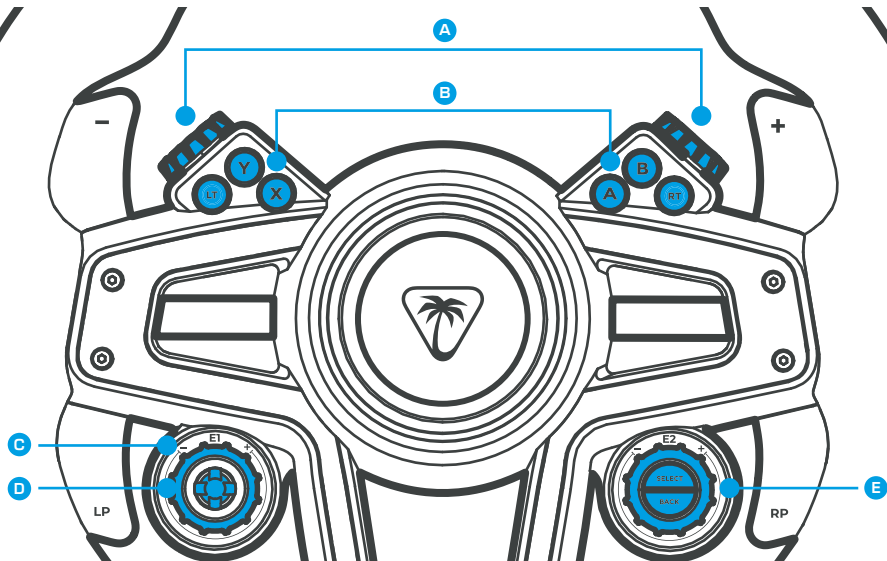

A Return to center switch

Bi-directional switch. Flick left or right to quickly change brake bias or check your blind spot. It can be configured as a game button, core control duplicate or V1 Race system function.

B Button cluster

Core function buttons, ergonomically placed for easy access without accidental actuation.

C Mappable encoder

Rotary dial with tactile detent clicks. It can be configured as a game button, core control duplicate or V1 Race system function. Ideal for adjusting vehicle setups on-the-fly.

D D-Pad

Core 8-way directional pad used for menu navigation and view changes.

E Dashboard controls

Rotary dial for highlighting and altering product options on the screen. Use **Select** and **Back** to navigate through the features of the product.

CONTROL DESCRIPTION – WHEEL REAR

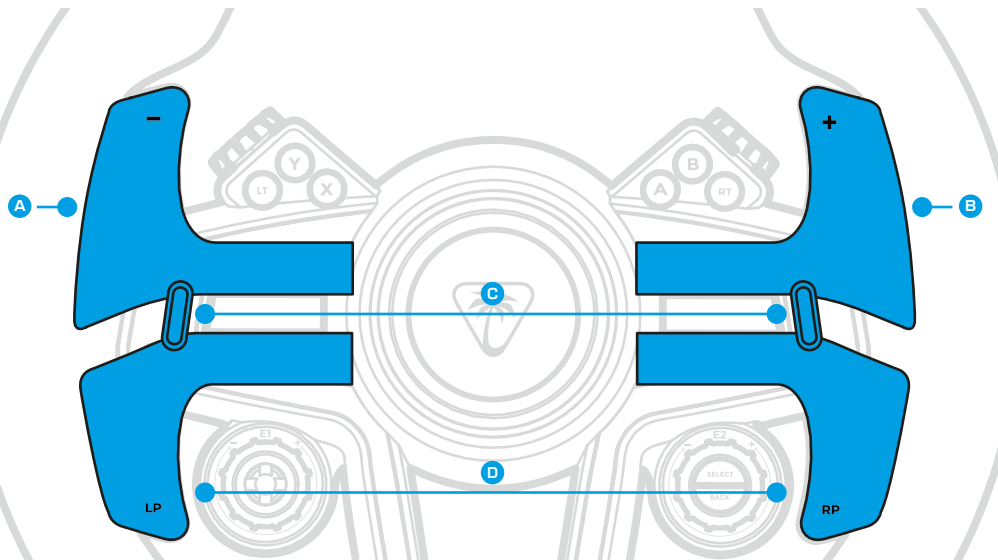

A Gear shift down

Crisp magnetic switches ensure reliable gear changes to help reduce speed going into a corner.

B Gear shift up

Crisp magnetic switches ensure reliable gear changes to help increase your speed at the optimum time.

C Quick access buttons

Conveniently placed rear wheel buttons, ideal for making fast system adjustments during a race.

D Analogue paddles

High-resolution analogue axis control. Can be set to clutch, handbrake, throttle or brake controls.

CONTROL DESCRIPTION – VELOCITYONE CONTROL UNIT (VCU)

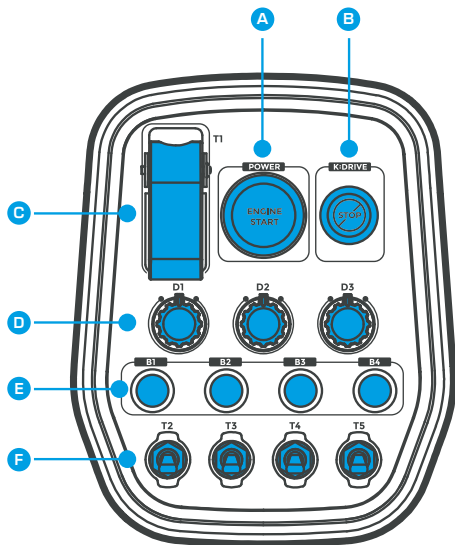

A Engine start

Acts as the primary power on/off for the system. A 2 second press and hold will power the whole system on, and a 6 second press will power the whole system off. This function is duplicated with the K: Drive button on the Wheelbase.

B K: Drive Stop

Pressing this button will instantly cut power to the entire VelocityOne Race system.

C T1

A latched two-way toggle switch. Lift the lid and flick to initiate. It can be configured as a game button, core control duplicate or VelocityOne Race system function.

D D1-3

Rotary dial with tactile detent clicks. It can be configured as a game button, core control duplicate or VelocityOne Race system function. D1 set to Volume, D2 set to Profile & D3 set to Force Feedback out of box.

E B1-4

Momentary digital buttons. They can be configured as a game button, core control duplicate or V1 Race system function.

F T2-5

Additional latched two-way toggle switches. They can be configured as a game button, core control duplicate or VelocityOne Race system function.

CONTROL DESCRIPTION – PEDAL UNIT

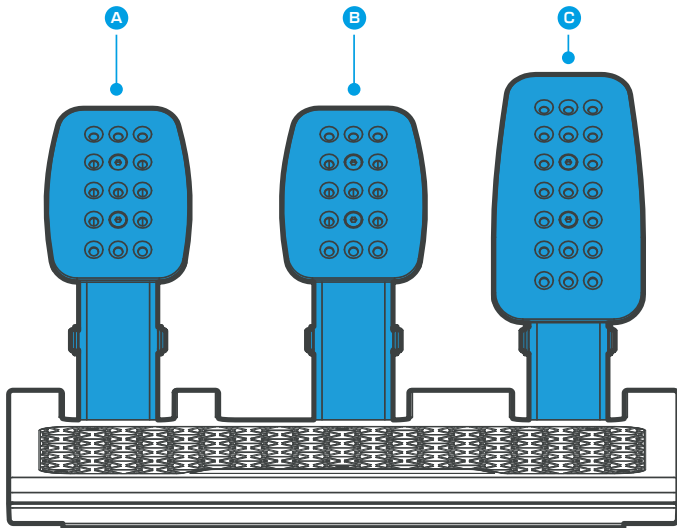

A Clutch

For changing gear in stick shift cars, more prominent in rally and drift cars. Can be lowered when not in use.

B Brake

Realistic pressure sensitive brake provided by custom load cell. Braking is proportionate to the pressure applied to the brake, not the distance the pedal has travelled.

C Throttle

High-resolution throttle axis ensures even the most minute of adjustments can be made to shave valuable time off your lap.

CONTROL DESCRIPTION – CONNECTION PORTS

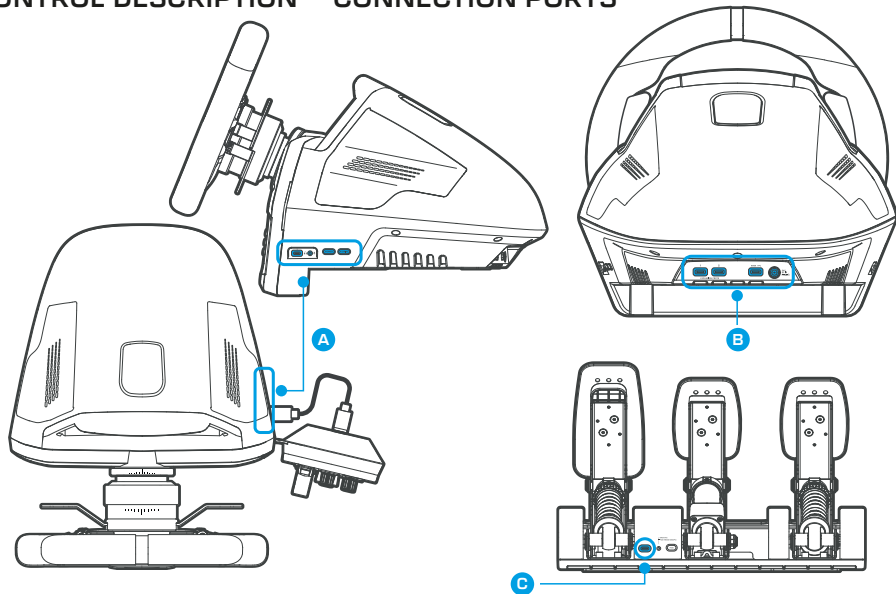

A VCU / Audio

USB-C port provides connection to the wheelbase for the VCU. 3.5mm audio port ensures full headset connectivity on Xbox and PC. System power and K: Drive stop buttons are duplicated if VCU is not in use. USB-C port is also on opposite side of wheelbase for left-handed usage.

B Rear connection panel

Mains power connection, a dedicated USB-C port for connection to console or PC, and two additional expansion ports are conveniently placed on the back of the wheelbase to ensure ease of access for Pedal Unit connectivity and future VelocityOne expansion modules.

C Pedal connectivity

USB-C port provides connection to the wheelbase on Xbox and PC or direct connection on PC only.

CONTROL DESCRIPTION – BUTTON CALLOUT CHART

This section provides an overview of the default out of box button mappings available on the product on Xbox and Windows PC platforms.

Due to the extended number of buttons on the device, button functionality will differ depending on the platform you are racing on.

- [*] On Xbox, the buttons labelled **Custom Sim Buttons** can be limited by the capabilities of the Xbox console operating system. The operation of these buttons are subject to Xbox operating system changes and developer support being added to simulation software. Please refer to the compatibility section of our Knowledgebase for a full list of titles that support these extra controls. If the custom buttons are not supported within the sim, these inputs can either be mapped as duplicates of standard Xbox wheel buttons, VelocityOne Race system functions, or have no function on Xbox. This can be done within the **BUTTONS** section of the RMD UI Interface.
- On Windows PC, all available buttons and axes will work as native USB Input device controls and can be mapped within the Control settings options of your race sim software.

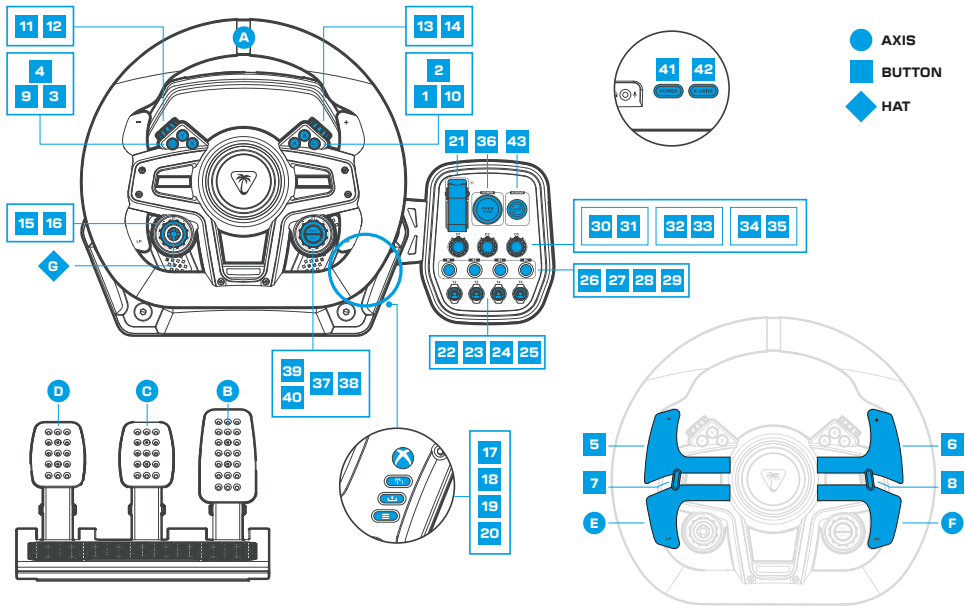

ID	Type	Location	Label	Xbox	Windows PC	Default Out of Box Mapping
1	Button	Wheel Module	A	Button A	Button 1	As Xbox/Windows column
2	Button	Wheel Module	B	Button B	Button 2	As Xbox/Windows column
3	Button	Wheel Module	X	Button X	Button 3	As Xbox/Windows column
4	Button	Wheel Module	Y	Button Y	Button 4	As Xbox/Windows column
5	Button	Wheel Module	-	Gear Down	Button 5	As Xbox/Windows column
6	Button	Wheel Module	+	Gear Up	Button 6	As Xbox/Windows column
7	Button	Wheel Module	LSB	XEB 1	Button 7	As Xbox/Windows column
8	Button	Wheel Module	RSB	XEB 2	Button 8	As Xbox/Windows column
9	Button	Wheel Module	LT	XEB 3	Button 9	As Xbox/Windows column

ID	Type	Location	Label	Xbox	Windows PC	Default Out of Box Mapping
10	Button	Wheel Module	RT	XEB 4	Button 10	As Xbox/Windows column
11	Rocker Switch	Wheel Module	RS1 -	XEB 5	Button 11	As Xbox/Windows column
12	Rocker Switch	Wheel Module	RS1 +	XEB 6	Button 12	As Xbox/Windows column
13	Rocker Switch	Wheel Module	RS2 -	XEB 7	Button 13	As Xbox/Windows column
14	Rocker Switch	Wheel Module	RS2 +	XEB 8	Button 14	As Xbox/Windows column
15	Rotary Dial	Wheel Module	E1 -	XEB 9	Button 15	As Xbox/Windows column
16	Rotary Dial	Wheel Module	E1 +	XEB 10	Button 16	As Xbox/Windows column
17	Button	Wheelbase	Guide	Xbox Guide	Button 17	As Xbox/Windows column
18	Button	Wheelbase	View	Xbox View	Button 18	As Xbox/Windows column

ID	Type	Location	Label	Xbox	Windows PC	Default Out of Box Mapping
19	Button	Wheelbase	Share	Xbox Share	Button 19	As Xbox/Windows column
20	Button	Wheelbase	Menu	Xbox Menu	Button 20	As Xbox/Windows column
21	Toggle Switch	VCU	T1	XEB 11	Button 21	As Xbox/Windows column
22	Toggle Switch	VCU	T2	XEB 12	Button 22	As Xbox/Windows column
23	Toggle Switch	VCU	T3	XEB 13	Button 23	As Xbox/Windows column
24	Toggle Switch	VCU	T4	XEB 14	Button 24	As Xbox/Windows column
25	Toggle Switch	VCU	T5	XEB 15	Button 25	As Xbox/Windows column
26	Button	VCU	B1	XEB 16	Button 26	As Xbox/Windows column
27	Button	VCU	B2	XEB 17	Button 27	As Xbox/Windows column

ID	Type	Location	Label	Xbox	Windows PC	Default Out of Box Mapping
28	Button	VCU	B3	XEB 18	Button 28	As Xbox/Windows column
29	Button	VCU	B4	XEB 19	Button 29	As Xbox/Windows column
30	Rotary Dial	VCU	D1 -	XEB 20	Button 30	Profile Slot -
31	Rotary Dial	VCU	D1 +	XEB 21	Button 31	Profile Slot +
32	Rotary Dial	VCU	D2 -	XEB 22	Button 32	K:Drive Strength -
33	Rotary Dial	VCU	D2 +	XEB 23	Button 33	K:Drive Strength +
34	Rotary Dial	VCU	D3 -	XEB 24	Button 34	Headset Volume -
35	Rotary Dial	VCU	D3 +	XEB 25	Button 35	Headset Volume +
36	Button	VCU	Engine Start	XEB 26	Button 36	As Xbox/Windows column

ID	Type	Location	Label	Xbox	Windows PC	Default Out of Box Mapping
37	Rotary Dial	Wheel Module	E2 -	RMD Navigation	RMD Navigation	As Xbox/Windows column
38	Rotary Dial	Wheel Module	E2 +	RMD Navigation	RMD Navigation	As Xbox/Windows column
39	Button	Wheel Module	Select	RMD Navigation	RMD Navigation	As Xbox/Windows column
40	Button	Wheel Module	Back	RMD Navigation	RMD Navigation	As Xbox/Windows column
41	Button	Wheelbase	Power	System Power on/off	System Power on/off	As Xbox/Windows column
42	Button	Wheelbase	K:Drive Stop	System Power on/off	System Power on/off	As Xbox/Windows column
43	Button	VCU	K:Drive Stop	System Power on/off	System Power on/off	As Xbox/Windows column
A	Axis	Wheel Module	Wheel	Wheel Axis	X Axis	As Xbox/Windows column
B	Axis	Pedal Unit	Throttle	Throttle	rX Axis	As Xbox/Windows column

ID	Type	Location	Label	Xbox	Windows PC	Default Out of Box Mapping
C	Axis	Pedal Unit	Brake	Brake	rY Axis	As Xbox/Windows column
D	Axis	Pedal Unit	Clutch	Clutch	rZ Axis	As Xbox/Windows column
E	Axis	Wheel Module	LP	Clutch	rZ Axis	As Xbox/Windows column
F	Axis	Wheel Module	RP	Handbrake	Z Axis	As Xbox/Windows column
G	D-Pad	Wheel Module	D-Pad	D-Pad	HAT Switch	As Xbox/Windows column

CONTROL DESCRIPTION – XBOX NAVIGATION

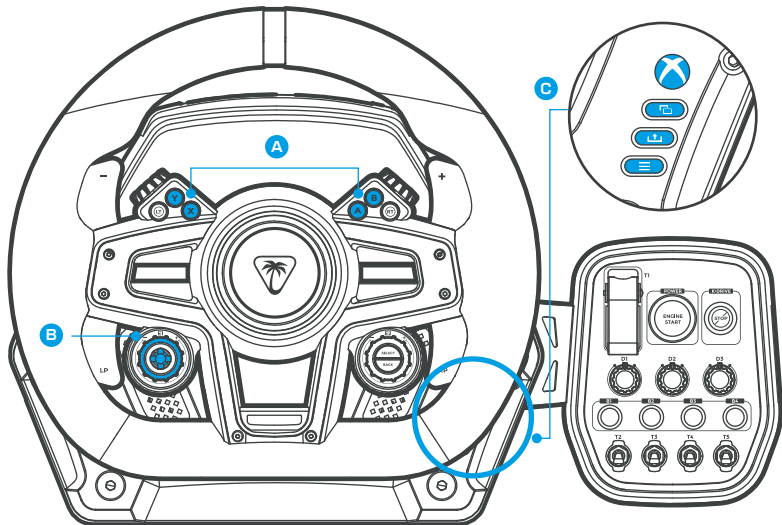

You can navigate your Xbox system using the controls on the product:

A Face buttons

Accept, Back and other system options.

B D-Pad

Navigate and select menu items.

C Xbox controls

Change view, share your content and open menus. Open Guide on Xbox.

SYSTEM SETUP - STEP 1 - MOUNTING

ADJUSTMENT TOOL STORAGE

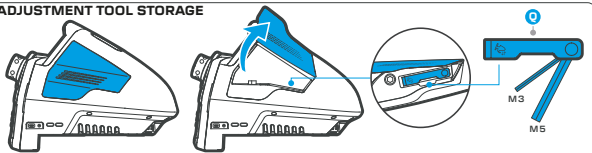

DESK / TABLE MOUNTING

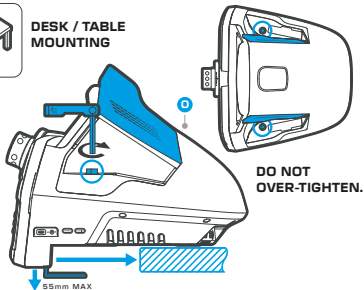

DO NOT OVER-TIGHTEN.

55mm MAX

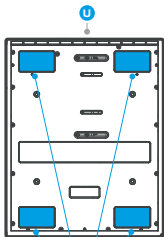
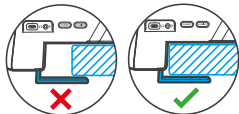

SOFT FLOOR

HARD FLOOR

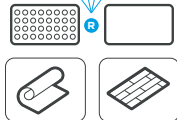

HARD MOUNTING

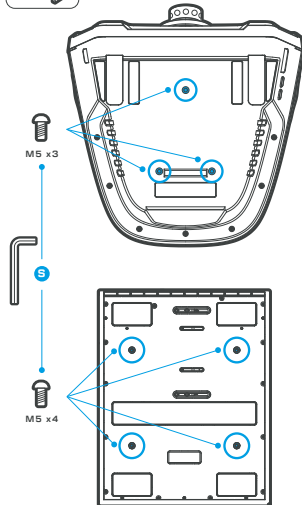

M5 x3



S



M5 x4

VelocityOne Race can be mounted in multiple ways:

- **Desk or table mounting** – use the provided adjustment tool to attach the wheel base to a surface using the built-in clamps. Depending on your floor surface you can use the provided Floor Stability Pads to use the Pedal Unit on a hard surface such as wooden flooring, or a soft surface such as carpet.
- **Hard mounting** – Use the Sim Frame Screws to securely hard mount the Race Wheelbase and pedals to a sim rig.

SYSTEM SETUP - STEP 2 - ATTACHING THE VCU

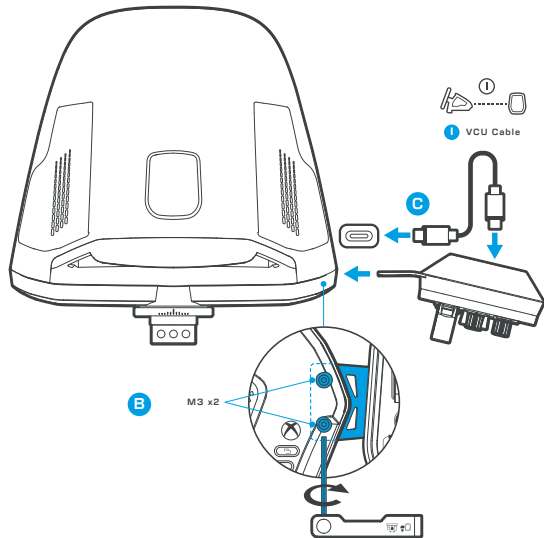
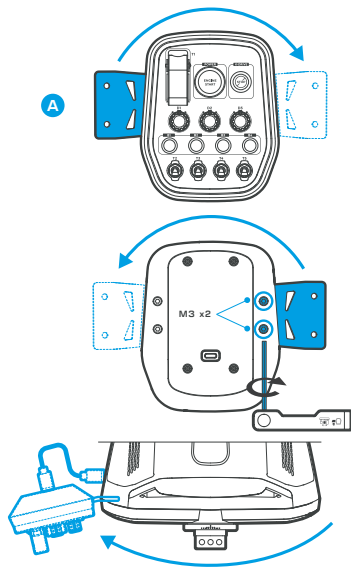

- A** The VCU is pre-configured for right-hand mounting to the wheel base. To change to left handed mounting, detach the VCU bracket from the side of the VCU by removing the two fastening bolts, place the bracket on the opposite side and reattach the fastening bolts.
- B** For ease of assembly, the VelocityOne Control Unit (VCU) should be attached before attaching the Race Wheel Module. First remove the two M3 fastening bolts housed within the wheel base front, slide the VCU bracket in to the desired slot on the side, then secure with the two M3 fastening bolts. **DO NOT OVER-TIGHTEN.**
- C** Connect the VCU Cable to the Wheel Base side USB port and to the USB port on the back of the VCU.

SYSTEM SETUP - ATTACHING THE WHEEL MODULE

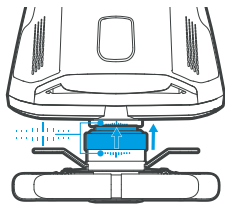
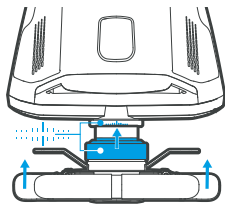
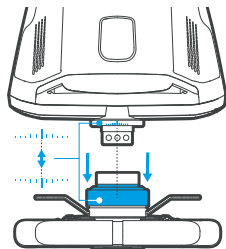
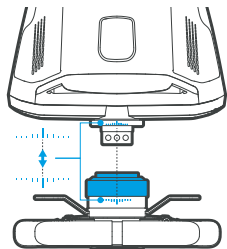

1

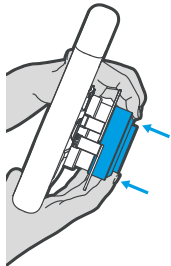

2

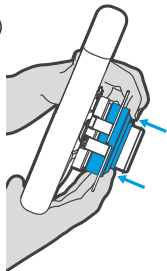

3

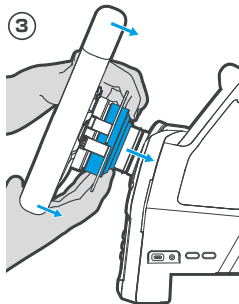

4

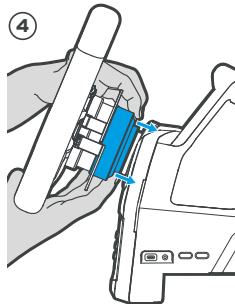

SYSTEM SETUP - CONNECTING TO XBOX / PC

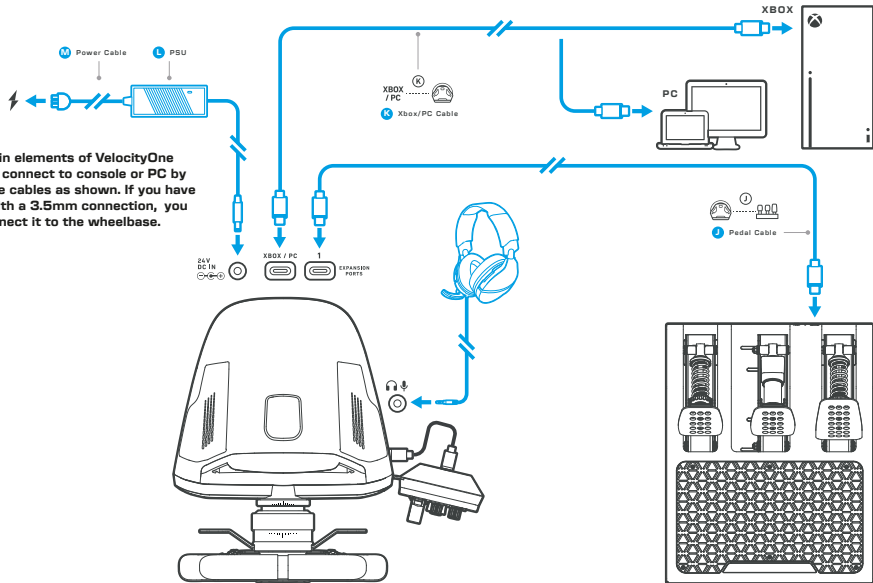

SYSTEM SETUP - ADJUSTING THE PEDAL UNIT

The Pedal Unit can be adjusted in many ways to suit your preferred driving style and position.

ADJUST PEDAL RESISTANCE

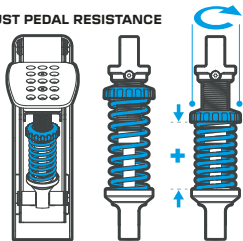

MOVE PEDAL PLATES

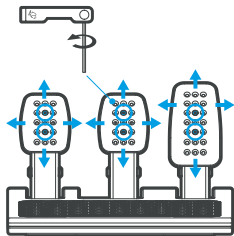

STOW CLUTCH

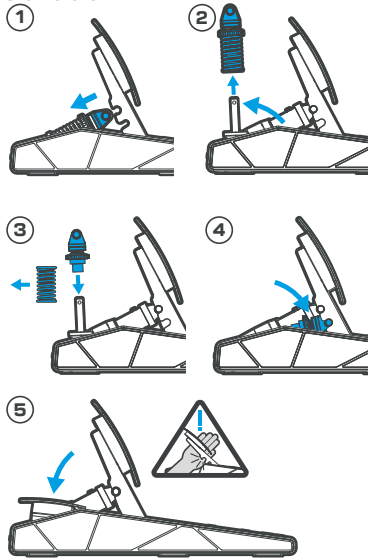

MOVE BRAKE PEDAL

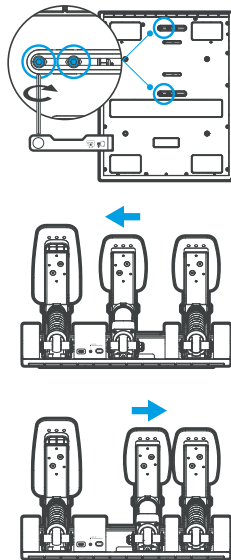

SYSTEM SETUP - POWERING ON

- ① CONNECT TO CONSOLE OR PC VIA USB

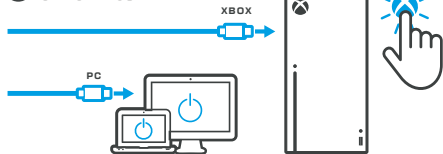

- ② POWER ON VELOCITYONE RACE

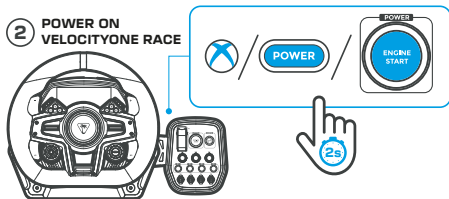

- ③ SELECT PLATFORM

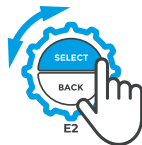
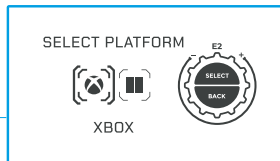
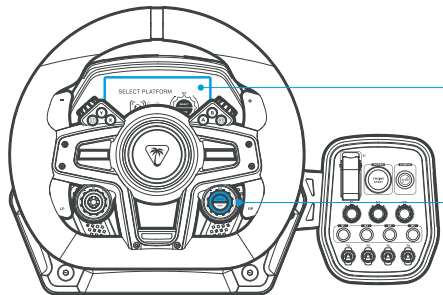

On first time power on of VelocityOne Race, you will be asked to select the correct platform. Use the E2 Wheel and SELECT button to make your choice to begin playing. Your choice will be saved for future use so this step only needs to be performed once. The platform can be changed again via the 'Platform' menu on the RMD.

SYSTEM SETUP - DEACTIVATING K: DRIVE

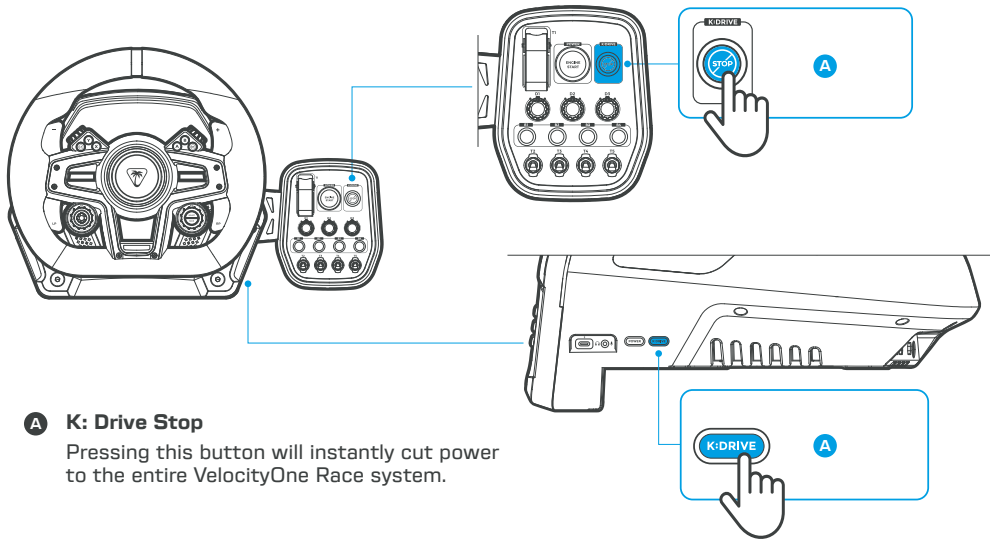



IMPORTANT SAFETY INFORMATION: READ BEFORE USING

VelocityOne Race features K: Drive - a high-fidelity direct drive motor capable of replicating many of the forces experienced in real life racing.

Please use caution when setting the force feedback strength to high levels, as in-game events such as crashing a car can produce realistic and rapid forces, which can be strong enough to cause injury or even pull the wheel from your hands. If this happens, do not attempt to stop the wheel with your hands, instead cut power to the motor and product by pressing the **"K: DRIVE STOP"** button on the VelocityOne Control Unit (VCU), or the **"K: DRIVE"** button on the side of the Wheelbase.

In some extreme cases it may become necessary to either disconnect the Wheelbase USB cable from your console or PC, or disconnect the power supply at the wall.

- Use only the power supply and cables supplied with this product
- Do not attempt to pass your hand or arm through the gap in the wheel to disconnect it from the wheelbase during gameplay, or while idle, powered and active
- Avoid extended gameplay sessions and take regular 10 to 15 minute breaks
- Ensure the wheelbase is securely attached to a surface or hard mounted as per the instructions in this Product Guide
- VelocityOne Race is not a toy, and as such is not intended for use by small children
- Do not leave the product powered and unattended
- Use only the Adjustment Tools provided to make adjustments to product features

RACE MANAGEMENT DISPLAY (RMD)

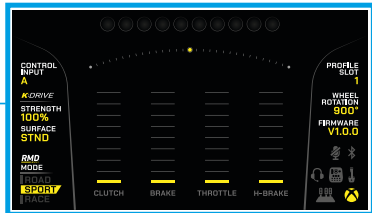
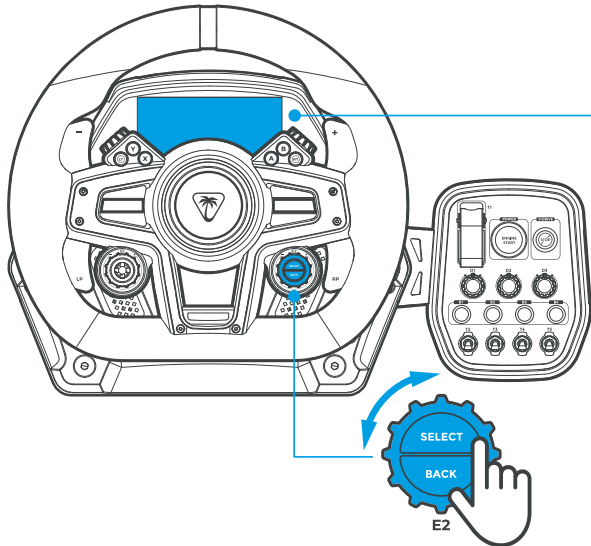

RMD
RACE MANAGEMENT DISPLAY

The **RACE MANAGEMENT DISPLAY (RMD)** can be used to tune VelocityOne Race performance and view real-time telemetry data from supported racing simulation titles*.

Use the **E2 WHEEL** to cycle through menu options and adjust product settings.

Press the **SELECT BUTTON** to select an option or accept a settings change.

Press the **BACK BUTTON** to navigate back to the dashboard.

*Game support dependent on developer integration.

RACE MANAGEMENT DISPLAY - DASHBOARD

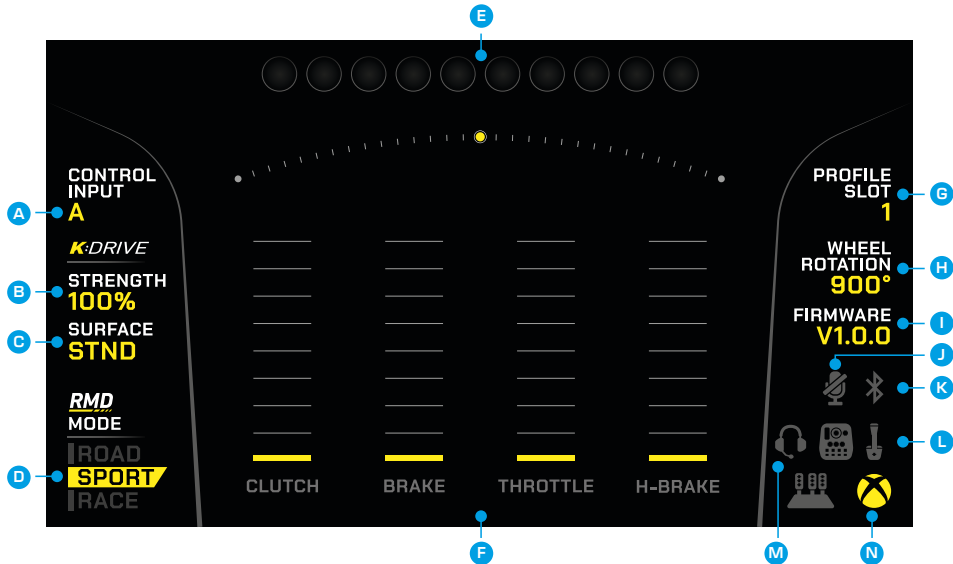

The **DASHBOARD** serves as the home screen of the Race Management Display (RMD). It displays the current state of the system, including active profile slot, K:Drive motor settings, RMD output settings, Wheel Rotation and connectivity status. It also shows the real time input of all the axes and buttons on the product.

- A** Active control input
- B** K:Drive Strength
- C** K:Drive Surface Type
- D** RMD mode
- E** RPM indicators
- F** Live axis outputs
- G** Active profile slot
- H** Wheel rotation
- I** Firmware version
- J** Mic status
- K** Bluetooth connection status
- L** Module Connection Status
- M** Headset connection
- N** Active platform

To access the main menu, rotate the E2 wheel to delve deeper into the options.

RACE MANAGEMENT DISPLAY - MAIN MENU



MAIN MENU

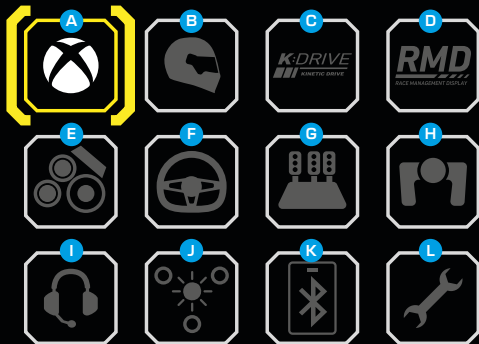

CONTROL
INPUT

A

K:DRIVE

STRENGTH
100%

SURFACE
STND

RMD
MODE

|ROAD
SPORT
|RACE

PROFILE
SLOT

1

WHEEL
ROTATION
90°

FIRMWARE
V1.0.0



PLATFORM

The **MAIN MENU** contains all the different options for configuring the VelocityOne Race. Rotate the **E2 dial** to show the menu and cycle through the different options. Press the **Select button** to enter the option or press the **Back button** to return to the Dashboard. All the customization options you can adjust are stored in the onboard memory. These are divided into two types:

Per Profile: A per profile setting can be different based on the profile you have selected to be active on the device. For example, you could have different button mappings for different games.

Global: A global setting will remain the same regardless of which profile is active on the device. For example, the Command Display brightness.

A Platform

B Profiles

C K: Drive

D Race Management Display (RMD)

E Button Mapping

F Wheel

G Pedals

H Paddles

I Headset mixer

J Lighting

K App link

L System

RACE MANAGEMENT DISPLAY - PLATFORM

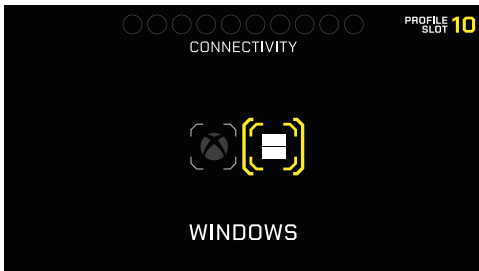
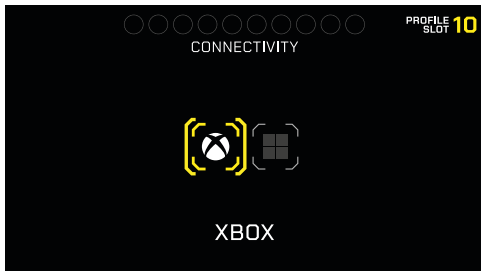

The **PLATFORM** section allows you to change the input mode of the product. It will be in Xbox mode by default. Rotate the **E2 dial** to highlight the platform icon and press the **Select button** to activate. The system will reboot to be used on the platform and the input mode will be stored in memory for next time you use the wheel.

RACE MANAGEMENT DISPLAY - PROFILES

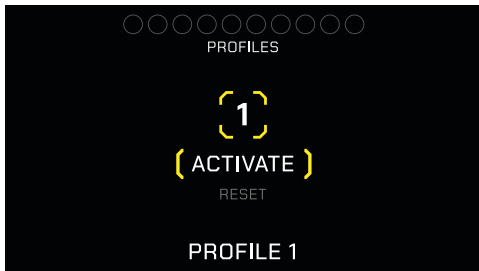
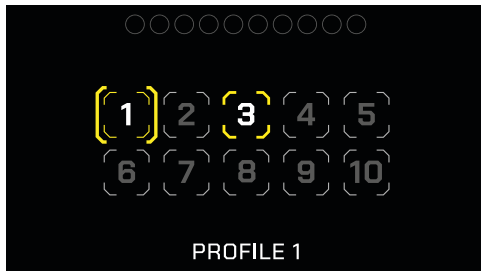
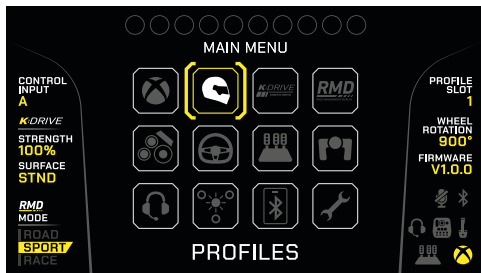

The **PROFILES** section allows you select which of the 10 onboard profile slots is active on the device. Select a profile using the **E2 dial**, then press the **Select button**. Now you can choose between Activating the profile slot or Resetting it. Activating will enable the profiled values on the product, resetting will revert the profiled values back to their defaults without affecting the other profiles you have customized.

When you change profile, your per-profile settings values will also change. For example, you could have a specific button mapping, and K:Drive setup in Profile 1 for a certain Race Sim, then change to Profile 2 for a completely different setup to suit a different car or sim.

RACE MANAGEMENT DISPLAY - K: DRIVE - TUNING

○ ○ ○ ○ ○ ○ ○ ○ ○ ○

MAIN MENU

CONTROL INPUT
A

K:DRIVE

STRENGTH
100%

SURFACE
STND

RMD
MODE

ROAD
SPORT
RACE

K:DRIVE

PROFILE SLOT
1

WHEEL ROTATION
90°

FIRMWARE
V1.0.0

Bluetooth, Gamepad, Xbox icons

○ ○ ○ ○ ○ ○ ○ ○ ○ ○

K:DRIVE

PROFILE SLOT 10

TUNING

○ ○ ○ ○ ○ ○ ○ ○ ○ ○

K:DRIVE • TUNING

PROFILE SLOT 10

K:DRIVE TUNING 50%

TUNING

○ ○ ○ ○ ○ ○ ○ ○ ○ ○

K:DRIVE • TUNING • CUSTOM

PROFILE SLOT 10

E2

100%

The **K:DRIVE** section allows you to tune multiple aspects of the Direct Drive motor. This feature is per-profile, so different force feedback responses can be saved and accessed on-the-fly.

TUNING

- This aspect controls the speed of response of the Direct Drive motor to a force feedback signal that has been sent from the simulation software.
- The higher the value, the faster the motor will respond.
- There are some preset values associated with different types of driving. For example, Rally is at the higher end of the scale because the wheel is in use much more in those types of scenarios.
- Rotate the **E2 dial** to highlight an option then press **Select** to save that value to the current active profile.
- You can also set a custom value by selecting the Custom option then rotate the dial to your desired value and press **Select** to save the value to the current active profile.

RACE MANAGEMENT DISPLAY - K: DRIVE - STRENGTH

○ ○ ○ ○ ○ ○ ○ ○ ○ ○

MAIN MENU

CONTROL INPUT
A

K:DRIVE

STRENGTH
100%

SURFACE
STND

RMD
MODE

ROAD
SPORT
RACE

PROFILE SLOT
1

WHEEL ROTATION
90°

FIRMWARE
V1.0.0

Bluetooth, Gamepad, Xbox icons

K:DRIVE

○ ○ ○ ○ ○ ○ ○ ○ ○ ○

PROFILE SLOT 10

K:DRIVE

STRENGTH

○ ○ ○ ○ ○ ○ ○ ○ ○ ○

PROFILE SLOT 10

K:DRIVE • STRENGTH

K:DRIVE STRENGTH 25%

LOW

○ ○ ○ ○ ○ ○ ○ ○ ○ ○

PROFILE SLOT 10

K:DRIVE • STRENGTH • CUSTOM

E2

100%

STRENGTH

- This aspect controls the peak response force of the Direct Drive motor to a force feedback signal that has been sent from the simulation software.
- The higher the value, the higher the force the wheel will output in response to an in-race event.
- There are some preset values to quickly change between low, medium and high.
- Rotate the **E2 dial** to highlight an option then press **Select** to save that value to the current active profile.
- You can also set a custom value by selecting the Custom option then rotate the **E2 dial** to your desired value and press **Select** to save the value to the current active profile.

RACE MANAGEMENT DISPLAY - CENTRE SPRING

○ ○ ○ ○ ○ ○ ○ ○ ○ ○

MAIN MENU

CONTROL INPUT
A

K:DRIVE
STRENGTH
100%
SURFACE
STND

RMD
MODE
ROAD
SPORT
TRACE



PROFILE SLOT
1

WHEEL
ROTATION
90°
FIRMWARE
V1.0.0



K:DRIVE

○ ○ ○ ○ ○ ○ ○ ○ ○ ○

PROFILE SLOT 10

K:DRIVE



CENTRE SPRING

○ ○ ○ ○ ○ ○ ○ ○ ○ ○

PROFILE SLOT 10

K:DRIVE • CENTER SPRING

K:DRIVE CENTER SPRING 25%



LOW

○ ○ ○ ○ ○ ○ ○ ○ ○ ○

PROFILE SLOT 10

K:DRIVE • CENTER SPRING STRENGTH • CUSTOM

E2



100%

CENTRE SPRING

- This aspect controls the strength at which the wheel tries to return to centre, once moved left or right.
- The higher the value, the higher the force the wheel exerts to return to its center point.
- There are some preset values to quickly change between low, medium and high.
- Rotate the **E2 dial** to highlight an option then press **Select** to save that value to the current active profile.
- You can also set a custom value by selecting the Custom option then rotate the **E2 dial** to your desired value and press **Select** to save the value to the current active profile.

RACE MANAGEMENT DISPLAY - DAMPING

○ ○ ○ ○ ○ ○ ○ ○ ○ ○

MAIN MENU

CONTROL INPUT
A

K:DRIVE

STRENGTH
100%

SURFACE
STND

RMD
MODE

ROAD
SPORT
RACE

K:DRIVE

PROFILE SLOT
1

WHEEL ROTATION
90°

FIRMWARE
V1.0.0

Bluetooth, Gamepad, Xbox icons

○ ○ ○ ○ ○ ○ ○ ○ ○ ○

PROFILE SLOT 10

K:DRIVE

DAMPING

○ ○ ○ ○ ○ ○ ○ ○ ○ ○

PROFILE SLOT 10

K:DRIVE • DAMPING

K:DRIVE DAMPING 25%

LOW

○ ○ ○ ○ ○ ○ ○ ○ ○ ○

PROFILE SLOT 10

K:DRIVE • DAMPING • CUSTOM

E2

100%

DAMPING

- This aspect controls the resistance felt when steering a vehicle.
- The higher the value, the higher the resistance felt.
- There are some preset values to quickly change between low, medium and high.
- Rotate the **E2 dial** to highlight an option then press **Select** to save that value to the current active profile.
- You can also set a custom value by selecting the Custom option then rotate the **E2 dial** to your desired value and press **Select** to save the value to the current active profile.

RACE MANAGEMENT DISPLAY - LIVE OUTPUT

○ ○ ○ ○ ○ ○ ○ ○ ○ ○

MAIN MENU

CONTROL INPUT
A

KDRIVE
STRENGTH
100%
SURFACE
STND

RMD
MODE
ROAD
SPORT
TRACE

PROFILE SLOT
1

WHEEL ROTATION
90°

FIRMWARE
V1.0.0

Bluetooth, Keyboard, Mouse, Xbox icons

RMD

○ ○ ○ ○ ○ ○ ○ ○ ○ ○

PROFILE SLOT **10**

TELEMETRY

▶ ◀ (highlighted), ⏸, ⏹ icons

LIVE OUTPUT

● ● ● ● ● ● ● ● ● ●

PROFILE SLOT **10**

RPM **2573**

SPEED **210**

ABS
TCS

4

BATT
FUEL

LAP TIME **16:45.053** DELTA **+0.73** POS **6**

○ ○ ○ ○ ○ ○ ○ ○ ○ ○

PROFILE SLOT **10**

TELEMETRY • LIVE OUTPUT

WAITING FOR GAME DATA

The RMD section allows you to adjust multiple aspects of the Race Management Display. This feature is per-profile, so different RMD configurations can be saved and accessed on-the-fly.

LIVE OUTPUT

- This section displays any live telemetry data that is being managed and sent to the screen either directly from a race sim, or from any supported 3rd party software.
- If a supported application is sending data, it will be displayed in one of the three output styles available. If there is no data being sent, you will see the '**WAITING FOR GAME DATA**' message.
- For a full list of supported titles and platforms please review our knowledgebase for regular updates.

RACE MANAGEMENT DISPLAY - OUTPUT STYLE

○ ○ ○ ○ ○ ○ ○ ○ ○ ○

MAIN MENU

CONTROL INPUT
A

K-DRIVE
STRENGTH
100%
SURFACE
STND

RMD
MODE
ROAD
SPORT
RACE

RMD

PROFILE SLOT
1

WHEEL ROTATION
90°

FIRMWARE
V1.0.0

○ ○ ○ ○ ○ ○ ○ ○ ○ ○

TELEMETRY

PROFILE SLOT 10

OUTPUT STYLE

○ ○ ○ ○ ○ ○ ○ ○ ○ ○

TELEMETRY • OUTPUT STYLE

PROFILE SLOT 10

ROAD

○ ○ ○ ○ ○ ○ ○ ○ ○ ○

TELEMETRY • OUTPUT STYLE

PROFILE SLOT 10

SPORT

○ ○ ○ ○ ○ ○ ○ ○ ○ ○

TELEMETRY • OUTPUT STYLE

PROFILE SLOT 10

RACE

● ● ● ● ● ● ● ● ● ●

PROFILE SLOT 10

LAP TIME 16:45.053 DELTA +0.73 POS 6

● ● ● ● ● ● ● ● ● ●

PROFILE SLOT 10

FUEL BATT POS 6 +0.73 DELTA

● ● ● ● ● ● ● ● ● ●

PROFILE SLOT 10

YELLOW FLAG

LAP TIME BEST 16:45.053 DELTA +0.73 TIME ELAPSED 18:10

SPEED 210	FL 27	GEAR 4	FR 27	FUEL	BATT
LAP 87	PL 32		RR 32		
POSITION 6	RPM 2573		BBAL +0.0		

This section allows you to change the styling of the **LIVE OUTPUT** page. This means you can have a different style output to suit the type of vehicle you are driving.

You can choose between the following styles:

- **ROAD:** Based on a more conventional dashboard from modern road cars, including analogue dial readouts for speed and RPM.
- **SPORT:** Closer to a high-end sports car dashboard, with a mixture of analogue and digital status readouts.
- **RACE:** Inspired by the raw digital output displays found in competition race cars such as single-seater and GT. Provides maximum in-race data on a single screen.

Rotate the **E2 dial** to highlight an option then press Select to save that value to the current active profile.

Your **LIVE OUTPUT** screen will change to suit your preference.

RACE MANAGEMENT DISPLAY - RPM INDICATOR

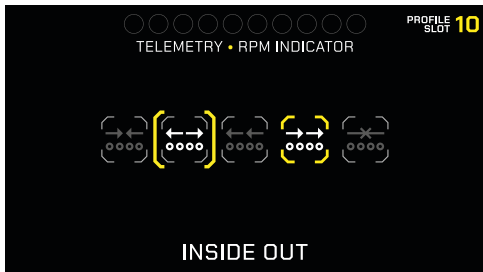
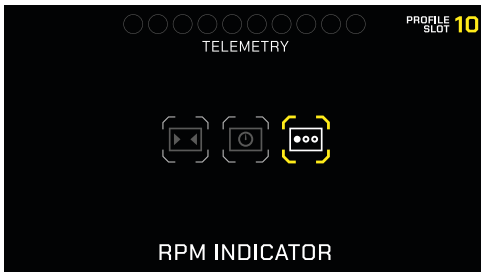
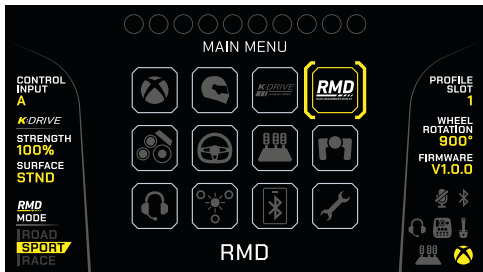

The **LIVE OUTPUT** screen can also replicate the RPM Indicator LEDs commonly used to highlight when to change gear. The **RPM INDICATOR** page allows you choose exactly how you want the simulated LEDs to be behave.

You can choose between the following:

- **OUTSIDE IN**
- **INSIDE OUT**
- **RIGHT TO LEFT**
- **LEFT TO RIGHT**
- **OFF**

Rotate the **E2 dial** to highlight an option then press Select to save that value to the current active profile.

Your **LIVE OUTPUT** screen will change to suit your preference.

RACE MANAGEMENT DISPLAY - BUTTONS

CONTROL INPUT
A

KDRIVE
STRENGTH
100%
SURFACE
STND

RMD
MODE
ROAD
SPORT
TRACE

MAIN MENU

PROFILE SLOT
1

WHEEL ROTATION
90°

FIRMWARE
V1.0.0

Bluetooth, USB, and Xbox logos are visible at the bottom.

BUTTONS

The interface shows a grid of icons for various functions. The 'Buttons' icon, which depicts three buttons, is highlighted with a yellow border.

PROFILE SLOT **10**

BUTTON MAPPING

X	A	B	X
Y	GEAR UP	GEAR DOWN	LSB
RSB	LT	RT	VIEW

B1 - VIEW MAPPING

The interface shows a grid of button mappings. The 'VIEW' button is highlighted with a yellow border. A yellow circle highlights the 'VIEW' button on the steering wheel graphic to the right.

PROFILE SLOT **10**

BUTTON MAPPING

MIC MON + B1	B2	B3	B4
B5	B6	B7	B8
B9	B10	T1	T2

B1 - MIC MONITOR - MAPPING

The interface shows a grid of button mappings. The 'MIC MON + B1' button is highlighted with a yellow border. A yellow circle highlights the 'MIC MONITOR' button on the steering wheel graphic to the right.

The **BUTTONS** section allows you to customize the mappable buttons on the product. This feature is per-profile, so different configurations can be saved and accessed on-the-fly.

Button mapping options include:

- **Replicating existing standard controls.** For example, mapping ABXY controls to the toggle switches on the VCU.
- **Audio controls.** For example, the buttons and dials could be set to alter Game volume, chat mix, mic monitoring, EQ status for a 3.5mm headset plugged into the wheelbase.
- **System controls.** For example, the buttons and dials could directly alter the K:Drive strength, or act as a shortcut to the LIVE OUTPUT screen.

First, use the **E2 dial** to highlight the button you want to configure.

Press the **Select** button to display the functions that can be mapped to the button.

Use the **E2 dial** to highlight the function, then press the **Select** button to save the mapping to the current active profile.

RACE MANAGEMENT DISPLAY - WHEEL - ROTATION

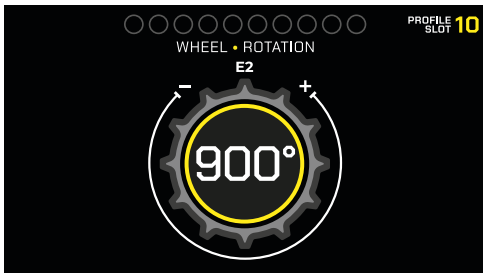
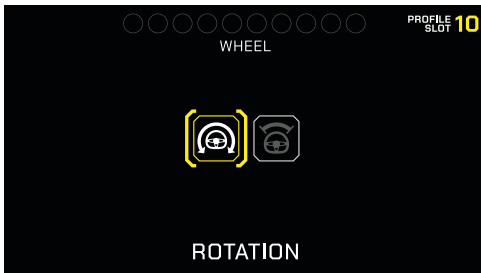

The **WHEEL** section allows you to alter the response characteristics of the main steering wheel input. This feature is per-profile, so different force feedback responses can be saved and accessed on-the-fly.

ROTATION

This aspect alters the maximum rotational angle of the wheel.

The higher the value, the more turns of the wheel will be required to reach full lock.

Rotate the **E2 dial** to define the preferred value then press **Select** to save that value to the current active profile.

RACE MANAGEMENT DISPLAY - WHEEL - DEADZONE

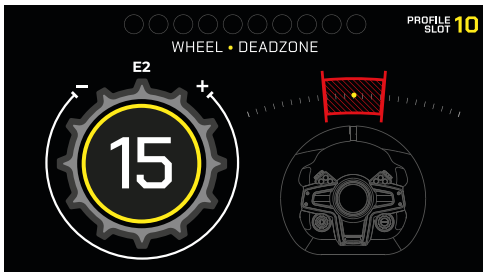
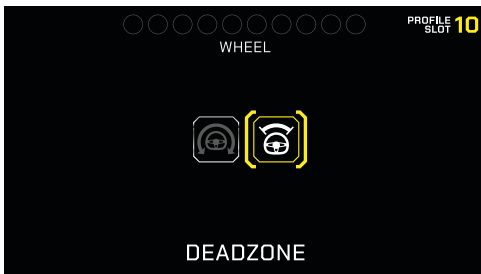
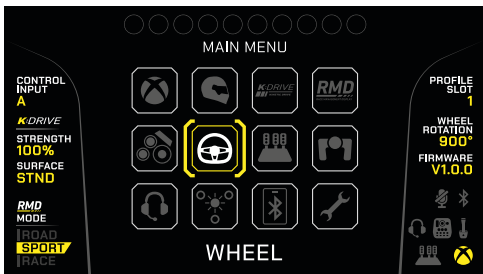

DEADZONE

This aspect alters the deadzone at the centre point of the wheel.

The higher the value, the more physical movement of the wheel is required to register a movement in the sim.

Rotate the **E2 dial** to define the preferred value then press **Select** to save that value to the current active profile.

RACE MANAGEMENT DISPLAY - PEDALS - DEADZONE

○ ○ ○ ○ ○ ○ ○ ○ ○ ○

MAIN MENU

CONTROL INPUT
A

KDRIVE
STRENGTH
100%
SURFACE
STND

RMD
MODE
ROAD
SPORT
RACE

PEDALS

PROFILE SLOT 1

WHEEL ROTATION 90°
FIRMWARE V1.0.0

○ ○ ○ ○ ○ ○ ○ ○ ○ ○

PROFILE SLOT 10

PEDALS

PEDAL DEADZONE

○ ○ ○ ○ ○ ○ ○ ○ ○ ○

PROFILE SLOT 10

PEDALS • PEDAL DEADZONE

CLUTCH

○ ○ ○ ○ ○ ○ ○ ○ ○ ○

PROFILE SLOT 10

PEDALS • PEDAL DEADZONE • CLUTCH

E2

7

The **PEDALS** section allows you to alter the response characteristics of the main steering wheel input. This feature is per-profile, so different force feedback responses can be saved and accessed on-the-fly.

DEADZONE

This aspect alters the deadzone at the beginning of the pedal travel. The higher the value, the more physical movement of the is required to register a movement in the sim. The clutch pedal also has an upper deadzone. This can be used to alter the point at which the in-sim clutch bite point is achieved. Increasing the upper deadzone will make the bite point occur sooner in the travel of the clutch pedal.

First, use the **E2 dial** to highlight the pedal you want to configure.

Press the **Select** button to edit the pedal.

Rotate the **E2 dial** to define the preferred value then press **Select** to save that value to the current active profile.

RACE MANAGEMENT DISPLAY - PEDALS - SENSITIVITY

○ ○ ○ ○ ○ ○ ○ ○ ○ ○

MAIN MENU

CONTROL INPUT
A

KDRIVE

STRENGTH
100%

SURFACE
STND

RMD
MODE

ROAD
SPORT
RACE

PROFILE SLOT
1

WHEEL ROTATION
90°

FIRMWARE
V1.0.0

⌂ ⚙️ 🎧 🎮 🏠 ⚙️ ⚙️ ⚙️

PEDALS

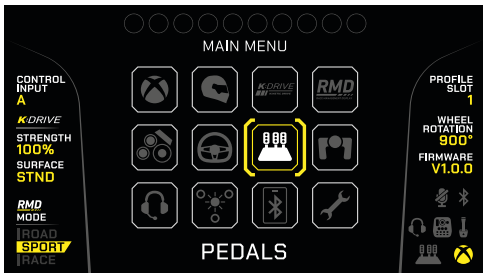

○ ○ ○ ○ ○ ○ ○ ○ ○ ○

PROFILE SLOT **10**

PEDALS

PEDAL SENSITIVITY

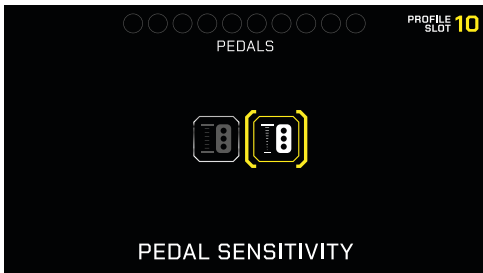

○ ○ ○ ○ ○ ○ ○ ○ ○ ○

PROFILE SLOT **10**

PEDALS • PEDAL SENSITIVITY

MEDIUM **50%**

CLUTCH

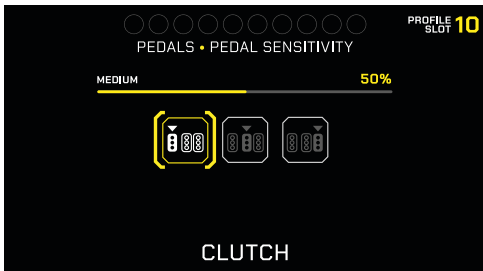

○ ○ ○ ○ ○ ○ ○ ○ ○ ○

PROFILE SLOT **10**

PEDALS • PEDAL SENSITIVITY • CLUTCH

MEDIUM **50%**

MEDIUM

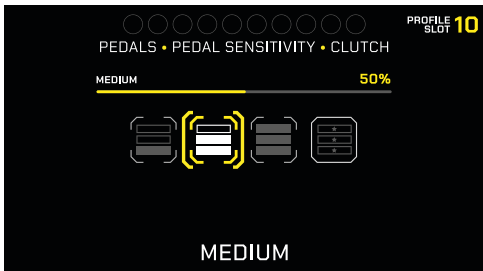

SENSITIVITY

There are ten sensitivity levels that can be applied to any of the pedals. A lower value will make the pedals less sensitive; a higher value will make the pedals more sensitive. A medium (50%) value will provide a linear 1:1 response between clutch and throttle pedal movement and input data.

First, use the **E2 dial** to highlight the pedal you want to configure.

Press the **Select** button to edit the pedal.

Rotate the **E2 dial** to highlight the preferred option then press **Select** to save that value to the current active profile.

The **PADDLES** section allows you to alter the response characteristics of the analogue paddles located below the gear shifters. This feature is per-profile, so different responses can be saved and accessed on-the-fly.

MAPPING

This aspect alters the paddle behaviour by changing the axis they report to the race sim software.

There are multiple options:

- **THROTTLE, BRAKE, CLUTCH:** These options replicate the axes used by the pedal module.
- **HANDBRAKE:** An additional axis that can be used to control the handbrake or e-brake in a car. Ideal for rally and drifting.

First, use the **E2 dial** to highlight the paddle you want to configure.

Press the **Select** button to edit the paddle.

Rotate the **E2 dial** to highlight the preferred option then press **Select** to save that value to the current active profile.

RACE MANAGEMENT DISPLAY - PADDLES - DEADZONE

○ ○ ○ ○ ○ ○ ○ ○ ○ ○

MAIN MENU

CONTROL INPUT
A

K-DRIVE
STRENGTH
100%
SURFACE
STND

RMD
MODE
ROAD
SPORT
RACE

PADDLES

PROFILE SLOT 1

WHEEL ROTATION 90°
FIRMWARE V1.0.0

○ ○ ○ ○ ○ ○ ○ ○ ○ ○

PROFILE SLOT 10

PADDLES

DEADZONE

○ ○ ○ ○ ○ ○ ○ ○ ○ ○

PROFILE SLOT 10

PADDLES • DEADZONE

0 5

LEFT

○ ○ ○ ○ ○ ○ ○ ○ ○ ○

PROFILE SLOT 10

PADDLES • DEADZONE • LEFT

E2

7

DEADZONE

This aspect alters the deadzone at the beginning of the paddle travel. The higher the value, the more physical movement of the paddle is required to register a movement in the sim.

First, use the **E2 dial** to highlight the paddle you want to configure.

Press the **Select** button to edit the paddle.

Rotate the **E2 dial** to define the preferred value then press **Select** to save that value to the current active profile.

RACE MANAGEMENT DISPLAY - PADDLES - CLUTCH BITE POINT

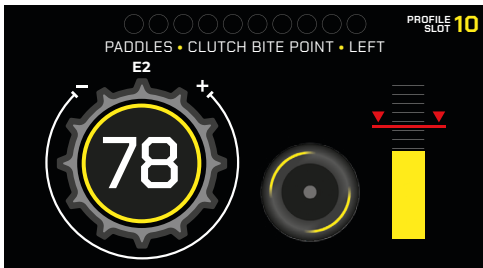
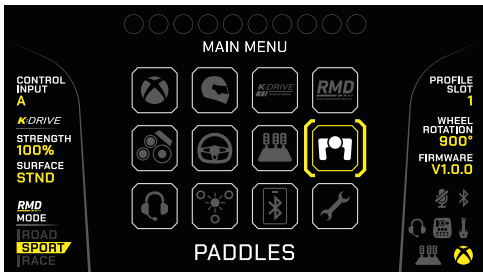

CLUTCH BITE POINT

This aspect alters the behaviour of the paddles when mapped to the clutch function. It enables you to tune the position of the clutch bite point, of the left paddle, to match the vehicle you are driving. This way you can achieve faster starts. Both the left and right paddles should be mapped to the clutch axis.

First, load a race where the car will have a standing start. Access the **CLUTCH BITE POINT** screen on the RMD. Hold the left clutch paddle down, then shift into 1st gear, and apply throttle pedal input. Gently start to lift the clutch paddle until the car starts to move, noting the position of the yellow bar on the RMD screen. Use the E2 dial to move the red line to match the position of the yellow bar at the point the car started to move.

Press the **Select** button to confirm the setting.

Retry the launch, this time depressing both the left and right paddles. When you want to launch, release the right paddle, and keep the left paddle fully depressed. The car will start to move, and the left paddle can be slowly released.

The bite point position may need to be tuned for the best launch possible.

RACE MANAGEMENT DISPLAY - HEADSET MIXER

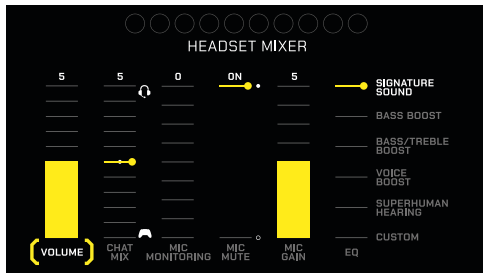
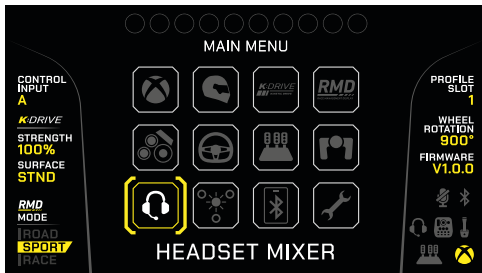

HEADSET MIXER

The HEADSET MIXER gives you full control to tune your audio experience. This feature is per-profile, meaning you could set different audio levels, including EQs, to be suit the sim you are playing. To use the feature, a 3.5mm headset must first be plugged into the audio port on the wheelbase.

First, use the **E2 dial** to highlight the audio option you want to configure.

Press the **Select** button to make the option active for editing.

Rotate the **E2 dial** to define the preferred value.

Press **Back** to end editing so that another audio option can be highlighted.

RACE MANAGEMENT DISPLAY - LIGHTING

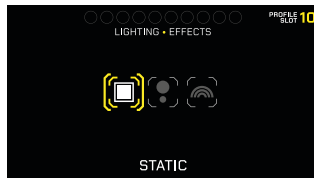
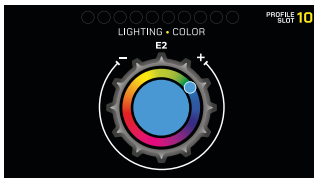
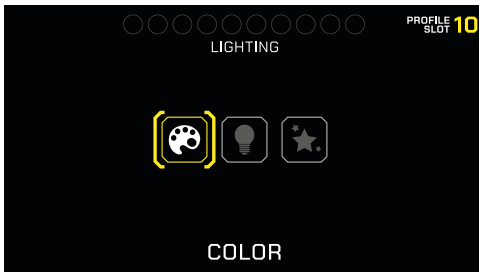
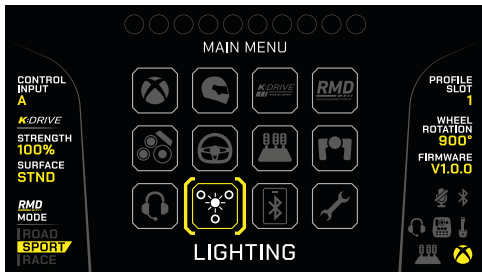

LIGHTING

This aspect alters the colour and behaviour of the RGB LEDs located in the wheel rim, wheelbase and VCU. This feature is per-profile, so different LED setups can be saved and accessed on-the-fly.

Use the **Color** option to select your preferred color by rotating the **E2 dial**.

Use the **Brightness** option to set your preferred brightness by rotating the **E2 dial**.

Use the **Effect** option to change from Static, breathing, or colour cycle LED responses.

RACE MANAGEMENT DISPLAY - APP LINK

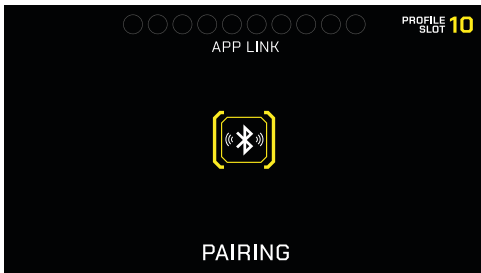
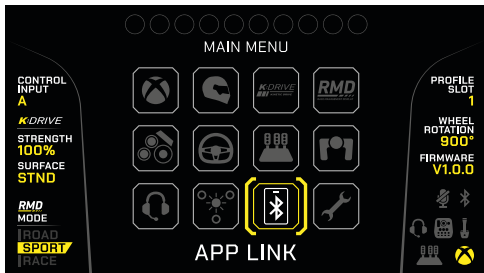

The **APP LINK** feature is used to establish a Bluetooth connection to your iOS or Android smart device. Once established you can use the **VelocityOne Tuner app** to configure and customize your system.

First, use the **E2 dial** to highlight the Bluetooth **PAIRING** option.

Press the **Select button** to make the system discoverable.

Locate the product entry in your smart device Bluetooth settings screen and tap to pair.

Alternatively, launch the VelocityOne Tuner app and tap the + button to initiate the pairing process.

The **SYSTEM** section allows you to adjust the performance of the global settings options. All options within the **SYSTEM** section will be stored in memory but will remain the same regardless of which Profile slot is active on the device. Here you can view and/or adjust:

- **Firmware:** Displays current firmware version.
- **Calibration:** Check on the input performance of the key system axes.
- **Screen Brightness:** Sets the backlight brightness of the Command Display.
- **Screen Timeout:** Sets the timeout duration to dim the screen when it is not in use. Setting to 0 will keep the screen always on.
- **Wheel Pairing:** This feature can be used to repair a wheel rim to the system or pair a new wheel rim to the system.
- **Reset to Defaults:** Be careful! Selecting this option will clear all the onboard memory settings and revert them to their factory default values.



TURTLE BEACH™



Any questions? Des questions? for setup videos and more, visit www.turtlebeach.com/support and look for **VelocityOne Race** in the **Simulation** category.

Warranty information

For warranty information and service, please visit www.turtlebeach.com/international-distributors .

Our goods come with guarantees that cannot be excluded under the Australian Consumer Law.

For complete details please visit www.turtlebeach.com/international-distributors .

To make a warranty claim in Australia during the Warranty Period, Purchaser should contact the

VTB repair centre: **Tecworks International Pty Ltd, 13 Distribution Place, Seven Hills**

NSW 2147, Tel: 1300 074 512