



Website: www.mova-tech.com

Manufactured by:

XingKuang Innovation Technology (Suzhou) Co., Ltd.

Made in China

FD20 Pro-EU-A00



AeroChef FD20 Pro

Air Fryer

User Manual

- FOR INDOOR HOUSEHOLD USE ONLY -

The illustrations in this manual are for reference only. Please refer to the actual product.

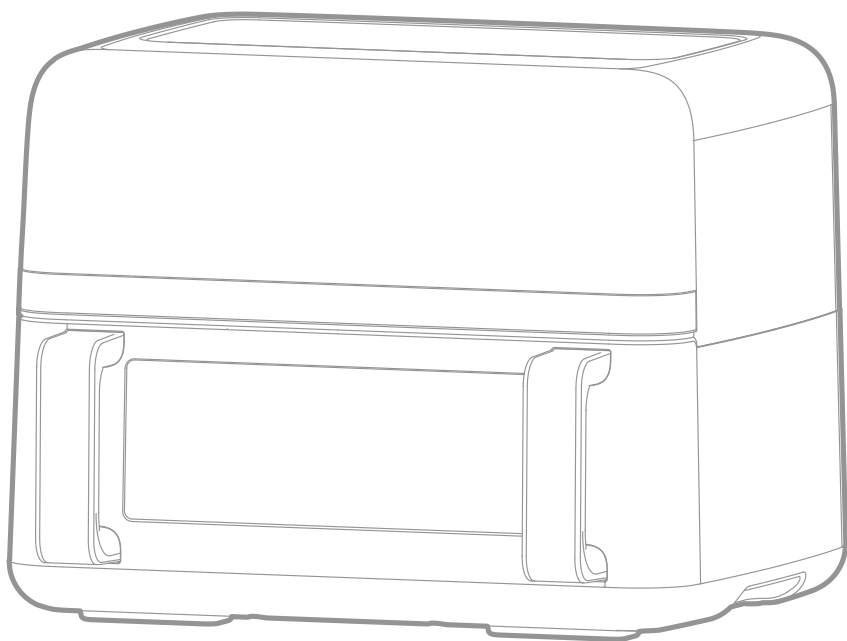

MOVA

THANK YOU

FOR PURCHASING THIS
MOVA AIR FRYER.

For more product information,
please visit www.mova-tech.com

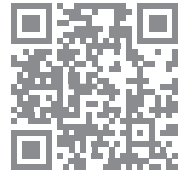

The high-quality product is engineered
for optimal performance.
If you have any questions on the product,
please contact us:
<https://global.mova-tech.com/pages/contact-us>

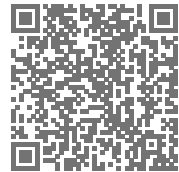

EN Safety Instructions

READ ALL INSTRUCTIONS BEFORE USING (THIS APPLIANCE). Failure to follow the warnings and instructions may result in electric shock, fire and/or serious injury.

Warning— To reduce the risk of fire, electric shock, or injury:



Caution, hot surface!

This appliance is for indoor use only.

This appliance can be used by children aged from 8 years and above and persons with reduced physical, sensory or mental capabilities or lack of experience and knowledge if they have been given supervision or instruction concerning use of the appliance in a safe way and understand the hazards involved. Children shall not play with the appliance. Cleaning and user maintenance shall not be made by children without supervision.

To avoid electric shock or fire due to short circuit, do not use the appliance if the power cord or plug is damaged or if the connection between the power outlet and the power plug is loose.

→ If the power cord is damaged, it must be replaced by the manufacturer, its service department or similarly qualified persons to avoid a hazard.

To avoid electric shock due to damage to the power cord and power plug, or fire due to short circuit, the following is strictly prohibited:

Damaging it, altering it, exposing it to or near high heat, forcibly bending it, twisting it, pulling on it, hanging it on a corner, placing a heavy object on it, bundling it, pinching it, or dragging the power cord.

Do not insert or unplug the power plug with wet hands. Always make sure hands are dry before handling the power plug or appliance.

Do not lick the power plug.

Do not pour water over the appliance, wash it directly with water, or immerse it in water (Not applicable to the frying basket, grill pan).

→ If water gets inside the appliance, Please contact after-sales service for maintenance.

Do not alter, disassemble or repair the appliance by yourself.

→ For repairs, Please contact after-sales service for maintenance.

To avoid causing burns, keep face, fingers and other parts of the body away from the exhaust port during use or just after use.

Do not use the appliance for any purposes other than those described in the instruction manual.

→ Mova will not be held responsible for conditions resulting from improper use or failure to follow the instruction manual .

Do not move the appliance while cooking.

Do not splash water or other liquids on the power plug.

To avoid sharing power supply with other electrical appliances and causing a fire due to overheating, be sure to use an AC power socket with a specification of 220 V-240 V / 15 A on its own.

Be sure to use a terminal strip of at least 15 A.

To avoid causing smoke, fire or electric shock, be sure to insert the power plug firmly all the way.

Safety Instructions

To avoid the risk of electric shock due to failure or electric leakage, single-phase bipolar grounded power outlet should be used for this appliance to ensure reliable grounding. If grounding device is not installed, it may cause electrostatic induction of other metal parts such as housing.

To appliance the power plug from being poorly insulated due to the accumulation of moisture and foreign objects, which may cause a fire, please clean the power plug regularly.

Unplug the power plug and wipe it with a dry cloth.

This appliance is not suitable for use by the following persons (including children): persons with reduced physical or mental abilities, or persons lacking experience and knowledge of use, unless they are supervised or instructed by a person responsible for their safety. Please be careful not to let children play with this appliance.

Be sure to keep the appliance out of the reach of children.

In case of abnormality or failure, please stop using it immediately and unplug the power plug.

Abnormalities and examples of failure:

- The power plug and power cord are abnormally hot.
- The power cord is damaged or intermittent power loss occurs after the power cord is touched.
- The main body is deformed or abnormally heated.
- The main body emits smoke or burnt smell.
- The main body is cracked, loosened, or making abnormal noises.

When cooking, there is no air coming from the exhaust port.

→ Please contact after-sales service for maintenance.

To avoid causing burns or injuries due to overheating or malfunction, do not use any non-exclusive or deformed frying basket.

To avoid electric shock, injury, burns, fire or causing discolouration, deformation, and damage to the furniture due to the heat discharged from the exhaust port, do not use this appliance in the following places:

- Near heat sources or in high humidity.
- On an uneven surface or non-heat-resistant mat.
- Near any walls or furniture.

To prevent the frying pan from falling out and damaging it, when moving the appliance, make sure that the frying pan is firmly in place. Do not carry the appliance at an angle.

Do not touch where the temperature is high during use or immediately after cooking.

The main body has a high temperature. Especially the parts such as the exhaust port and frying pan.

To avoid deforming the plug or causing a fire due to a short circuit, do not aim the exhaust port at the power plug.

→ When using this appliance, it should be placed in an open area. If it is placed in a cabinet, please ensure that there is enough space for heat dissipation to avoid overheating and malfunctioning.

Do not run the appliance with an empty basket.

EN Safety Instructions

It is recommended to perform a preheating for 10 minutes because a strange odor may be noticed upon first use. Some white smoke or odor may occur during the preheating process. This is normal.

To avoid malfunctioning or injuries, do not connect this appliance to an external timer or run it with an independent remote control system.

To prevent the power cord from being too close to other objects which might damage it, please ensure that there is more than 8 cm of space around the appliance.

To avoid causing electric shock, or fire due to short circuit, when unplugging the power plug, be sure to pull on the plug itself.

To avoid causing burns, injuries, or electric shock, leakage, or fire due to insulation aging, always turn off and unplug the appliance when removing the basket or when not in use.

Please wait until the main body has cooled down sufficiently before cleaning it.

When a power outage occurs during use, including when unplugging the power plug during cooking, the circuit breaker tripping, etc., and the power is on again within 10 minutes, the appliance will resume cooking. If it occurs in standby or menu mode, the appliance will return to being switched off after the power comes back on.

This appliance is intended to be used in household and similar applications such as:

- staff kitchen areas in shops, offices and other working environments;
- farm houses;
- by clients in hotels, motels and other residential type environments;
- bed and breakfast type environments.

Do not dispose of the appliance with regular household waste when it is no longer in use. Instead, take it to an official recycling collection point. By doing so, you contribute to environmental conservation.

WEEE Information	
	<p>All appliances bearing this symbol are waste electrical and electronic equipment (WEEE as in directive 2012/19/EU) which should not be mixed with unsorted household waste.</p> <p>Instead, you should protect human health and the environment by handing over your waste equipment to a designated collection point for the recycling of waste electrical and electronic equipment, appointed by the government or local authorities.</p> <p>Correct disposal and recycling will help prevent potential negative consequences to the environment and human health.</p> <p>Please contact the installer or local authorities for more information about the location as well as terms and conditions of such collection points.</p>

We, XingKuang Innovation Technology (Suzhou) Co., Ltd., hereby declares that this equipment is in compliance with the applicable Directives, European Norms, and amendments. The full text of the EU declaration of conformity is available at the following internet address: www.mova-tech.com

For detailed e-manual, please go to <https://www.mova-tech.com/pages/user-manuals-and-faqs>

EN Product Overview

Accessories (Fig.1)

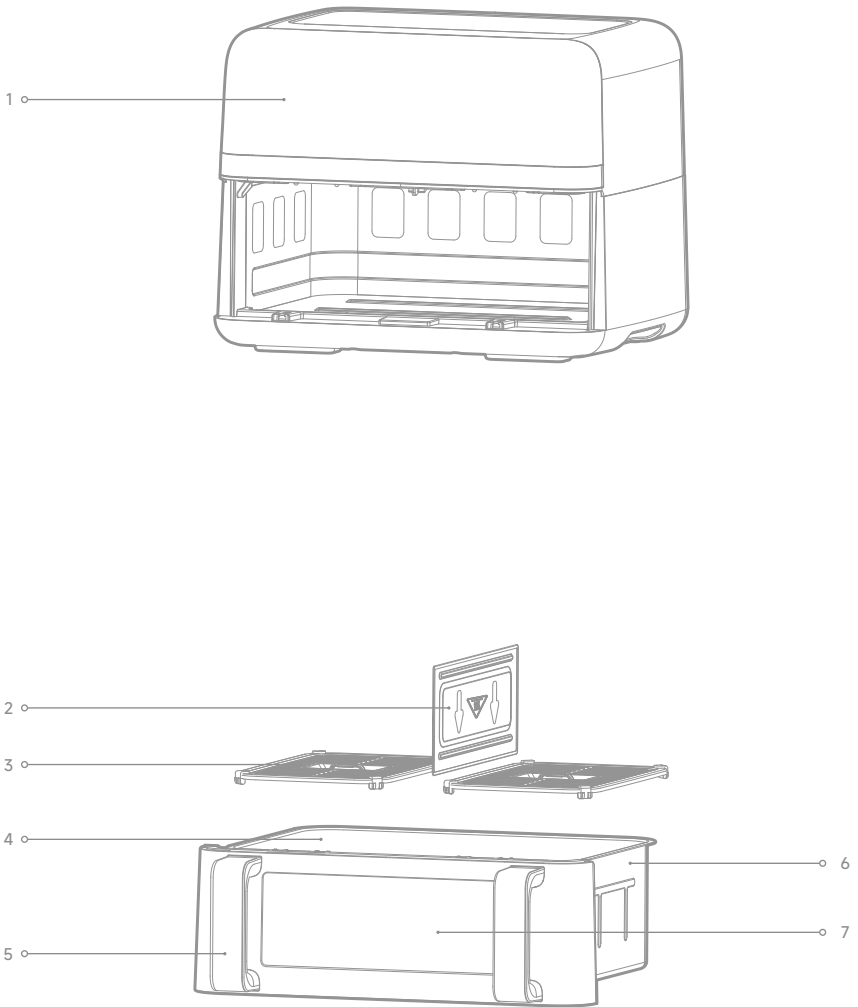

Product Overview

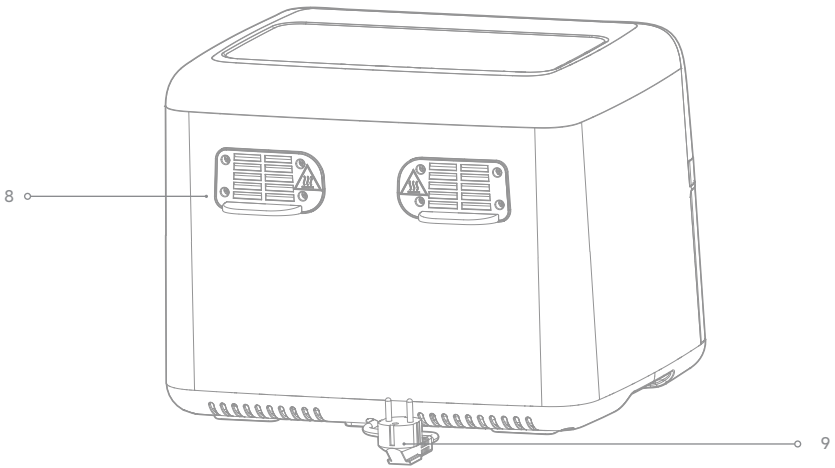

1. Control Panel
2. Divider

3. Grill Pan
4. Pot

5. Handle
6. Basket

7. Viewing Window
8. Air Outlet

9. Power Cord

EN Product Overview

Fig.2

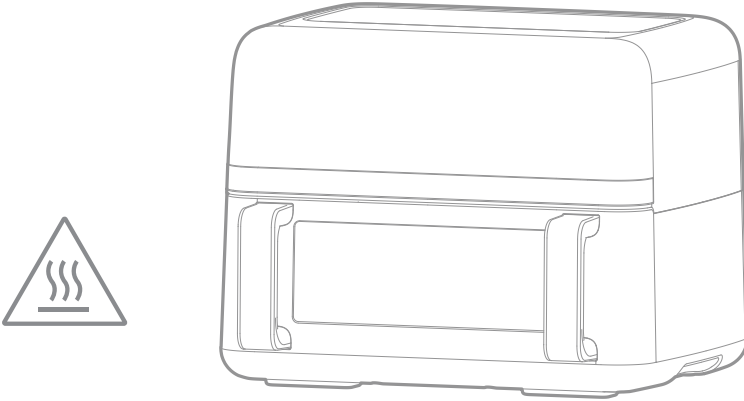
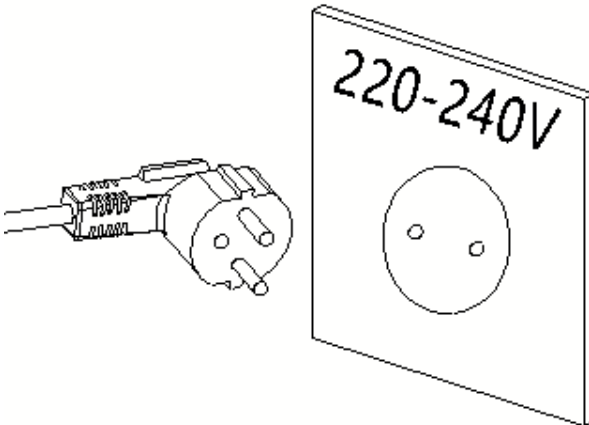

Fig.3



How to Use

Before Use

1. Remove all packing materials and stickers from the inside and outside of the air fryer.
2. Gently wipe down the exterior with a damp cloth or paper towel.
3. Do not use abrasive cleaning agents or scouring pads. Never immerse the air fryer or its plug in water or any other liquids.
4. This is an oil-free fryer that works using hot air. Do not fill the pot with oil or frying fat directly.

Notice: When your air fryer is heated for the first time, it may emit slight smoke or an odor. This is normal for many heating appliances and does not affect the safety of your appliance.

Preparing for Use

1. Place the air fryer on a stable, level, heat-resistant surface, away from areas that can be damaged by steam.
2. Insert the grill pans into the pot and put the pot back into the air fryer.

Notice: Do not fill the pot with oil or any other liquid. Do not put anything on top of the appliance, as this will disrupt the airflow and affect the results.

Using the Appliance

Hot Air Frying

1. Connect the power cord to a home socket.
2. Carefully pull the basket out of the air fryer.
3. Put the ingredients in the pot.
4. Slide the basket back into the air fryer.

Notice: Never use the pot without the grill pan in it.

Caution: Do not touch the pot during or shortly after use, as it gets very hot. Only hold the pot by the handle.

5. Determine the required preparation time for the ingredient (see "Cooking Tips").
6. Some ingredients require shaking halfway through the preparation time (see "Cooking Tips"). To shake the ingredients, pull the pot out of the appliance by the handle and shake it. Then slide the pot back into the air fryer.
7. When you hear the timer buzzer, the set preparation time has elapsed. Pull the pot out of the appliance.

Note: Press and hold the Power Key to turn off the appliance manually.

Tip: You can adjust the temperature or time according to your taste during use. Your settings will be kept for about 60 minutes after you pull the pot out of the appliance.

How to Use

8. Check if the ingredients are ready. If the ingredients are not ready yet, simply slide the basket back into the appliance and set the timer to a few extra minutes.
9. To remove ingredients (e.g. fries), pull the basket out of the air fryer and place it on wire rack. Do not turn the basket upside down, as any excess oil that has collected on the bottom of the basket will leak. The basket and the ingredients are hot. Depending on the type of ingredients in the pot, steam may escape from the air fryer.
10. Use clips or tools to transfer food to a plate.
11. When a batch of ingredients is ready, the air fryer is instantly ready for preparing another batch.

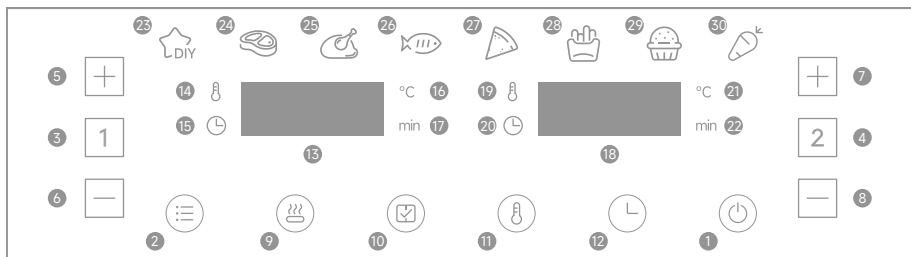

Function Indicators

Explanation of Icons

Key 1  -Power Key

Once the grill pan and pot are properly placed in the appliance, the power light will illuminate. Touch the Power Key to put the appliance into standby mode. After selecting the pot to be used, touching the Power Key again will start the cooking. Touching the Power Key for 2 seconds during cooking will turn off the appliance.

Note: During cooking, you can touch the Power Key to control the pause and start of cooking.

Key 2  -Menu Key

Touching the Menu Key enables you to select 8 popular menus(23-30). Once selected, the predetermined time and temperature function will begin.



Key 3  -The Left Pot Key



Touch the Left Pot Key, the icon will light up. The menu defaults to the first menu (DIY). At this time the DIY indicator will flash, the corresponding digital display will flash, and alternately display the default temperature and time of the DIY program. When the temperature is displayed, the temperature indicator on the upper left of the display will remain on. When the time is displayed, the time indicator on the lower left of the display will remain on. Touching the Left Pot Key for 2 seconds to cancel the selection of the pot, and the appliance will enter the standby mode.

Key 4  -The Right Pot Key



Touch the Right Pot Key, the icon will light up. The menu defaults to the first menu (DIY). At this time, the DIY indicator will flash, the corresponding digital display will flash, and alternately display the default temperature and time of the DIY program. When the temperature is displayed, the temperature indicator on the upper right of the display will remain on. When the time is displayed, the time indicator on the lower right of the display will remain on. Touching the Right Pot Key for 2 seconds to cancel the selection of the pot, and the appliance will enter the standby mode.

Control Panel Instruction

Key 5  & Key 6  –Temperature and Timer Control Keys for the Left Pot
The Key 5 and Key 6 enable you to increase or decrease the cooking temperature by 5°C at a time for the left pot. Holding down the key will rapidly change the temperature. These keys can also increase or decrease the cooking time for the left pot by 1 minute at a time. Holding down the key will rapidly change the time. Time control range: 1 min-60 min.

Key 7  & Key 8  –Temperature and Timer Control Keys for the Right Pot
The Key 7 and Key 8 enable you to increase or decrease the cooking temperature by 5°C at a time for the right pot. Holding down the key will rapidly change the temperature. These keys can also increase or decrease the cooking time for the right pot by 1 minute at a time. Holding down the key will rapidly change the time. Time control range: 1 min-60 min.

Key 9  –Preheat Key

Touch  or , then touch the Preheat Key twice to start the device. The preheat function defaults to 160 degrees for 3 minutes.

Key 10  –Sync Finish Key

Touch the Sync Finish Key to synchronize the end times of two menus with different cooking times.

Key 11  –The Temperature Key

Key 12  –The Time Key

Indicator Lights

Indicator light "13" – Digital display for the left pot

Indicator light "14" – Temperature light for the left pot

Indicator light "15" – Timer light for the left pot

Indicator light "16" – Temperature unit indicator light for the left pot

Indicator light "17" – Time unit indicator light for the left pot

Indicator light "18" – Digital display for the right pot

Indicator light "19" – Temperature light for the right pot

Indicator light "20" – Timer light for the right pot

Indicator light "21" – Temperature unit indicator light for the right pot

Indicator light "22" – Time unit indicator light for the right pot

Indicator light "23-30" – Menu indicator

1.Boot Mode





Confirm that the grill pan is correctly installed in the appliance. Connect the power cord to a home socket. After one beep, all the lights will illuminate for 1 second and then extinguish. The Power Key will remain illuminated.

2.Standby Mode

Touch the Power Key, and the Pot 1 Selection Icon  and Pot 2 Selection Icon  indicator lights will turn on, putting the appliance into standby mode. If the appliance is in the standby mode and remains inactive for 5 minutes, it will revert to boot mode.

3.Single Pot Working Mode

3.1 Operation

- Touch the icon for Pot 1  or Pot 2 . The function and menu indicators light up and remain on, with the DIY indicator flashing as the default menu. The other indicators remain on. The temperature and time indicators flash.
- Press and hold the icon  or  for 2 seconds to cancel the selection for the left pot or right pot. If both pots are canceled, the appliance reverts to standby mode.

3.2 Menu Selection

- Touch the Menu Key to select the desired menu. Adjust the temperature and time according to the food.
- Temperature adjustment: Each press changes the temperature by 5°C. Press and hold the increase or decrease key for continuous adjustment. The temperature range is 40°C - 230°C when using DIY mode.
- Time adjustment: Each press changes the time by 1 minute. The time range is 1 minute - 60 minutes.

3.3 Starting Cooking

- After setting the recipe, temperature, and time, touch the Power Key to start the cooking. The display shows the current cooking time in a countdown manner. The selected recipe indicator remains on, while others turn off.

3.4 Adjusting During Cooking

- To adjust the temperature or time during cooking, touch the Temperature or Time Key Icon once, then use the Increase or Decrease Key Icon to adjust. The appliance will continue working during the adjustment.

3.5 Resetting During Cooking

- To reset the recipe during cooking, touch the Power Key to pause. The heater and motor stop working, and the recipe indicator and display screen flash. Adjust the recipe, temperature, and time as needed.

3.6 Stopping Cooking

- Touch the Power Key during cooking to stop. If no further action is taken, the appliance will automatically return to standby mode after 5 minutes.

3.7 Turning Off

· Press and hold the Power Key for 2 seconds during cooking to turn off the appliance. The heater and motor stop. The display screen shows "OFF", and the buzzer beeps.

3.8 End of Cooking

· After cooking, the display screen shows "OFF", and the buzzer beeps 5 times. The screen turns off, and the appliance returns to standby mode.

3.9 Removing the Pot

· During cooking, if the pot is removed, the display screen will show "OPEN", and the appliance will stop working. Once the basket is reinserted, the appliance resumes its previous operation.

4. Double Pots Working Mode

4.1 Start the 2 Pots

4.1.1 Setup Each Pot

· Select one pot to adjust the menu, temperature and time. Select the other pot to adjust its parameters.

4.1.2 Starting Pots Simultaneously

· Touch the Power Key to start 2 pots at the same time.
· The icon of the Power Key and the recipe indicator for the 2 pots will flash once every 6 seconds. The display screens for the left and right pots will alternate every 3 seconds.

4.1.3 Starting Pots Independently

· You can start the left pot first by touching the Power Key after setting its parameters. Then set the parameters for the right pot.
· Once the right pot is ready, touch the Power Key again to start the right pot.

4.1.4 Displaying Temperature and Time During Operation

· During operation, touching the Temperature Key once will show the temperature on the left and right display screens.
· If no action is taken for 3 seconds, the display will show the time.

4.2 Adjust during the Pots Working Process

4.2.1 Adjusting Temperature or Time for the Left Pot

· If you need to adjust the temperature or time for the left pot while the 2 pots are working simultaneously, touch the Left Pot Key and adjust the parameters. Note that the menu cannot be adjusted in this state.
· If no action is taken within 10 seconds after adjusting, the display will automatically return to its normal mode.

4.2.2 Adjusting Temperature or Time for the Right Pot

· To adjust the temperature or time for the right pot, follow the same procedure as described in 4.2.1.

Operation Instruction

4.2.3 Adjusting Menu and Temperature or Time During Cooking

- If you need to adjust the menu, temperature or time during the working process, touch the Left Pot Key or the Right Pot Key in sequence, followed by the Power Key. This will put the left or right pot into the pause mode.
- To resume working after adjusting, touch the Power Key again.

4.2.4 Automatic Standby Mode

- If the pot remains in pause mode with no further operation in 5 minutes, it will automatically enter standby mode.

4.3 Stop Left Pot or Right Pot

4.3.1 Select the pot you wish to stop by touching the Left or Right Pot Key.

Press and hold the Power Key for 2 seconds. The selected pot stops working and returns to standby mode.

4.4 Pause the 2 Pots

4.4.1 Pausing 2 Pots

- Touching the Power Key once during working, the 2 pots enter the pause mode simultaneously. The screens and menus for the 2 pots will flash.
- Touch the Power Key again to resume working for the 2 pots.

4.4.2 Automatic Return to Standby Mode

- If both pots are paused and there is no further operation in 5 minutes, they will automatically stop working and return to standby mode after 5 minutes.

4.4.3 Adjusting During Pause

- Press the Left Pot Key or the Right Pot Key to adjust the menu, temperature or time while the 2 pots are paused.
- After adjusting, touch the Power Key once to resume working for the 2 pots.

4.4.4 Stopping 2 Pots Simultaneously

- Touch the Power Key once to pause the 2 pots during working.
- Press and hold the Power Key for 2 seconds to stop both pots. The screens displays "OFF", and the appliance returns to standby mode after a prompt sound of "beep".

4.5 Stop the 2 Pots

4.5.1 Manually Stop 2 Pots

During working, press and hold the Power Key for 2 seconds, both pots stops working and the screens display "OFF". The appliance enters standby mode after a prompt sound of "beep".

4.5.2 Automatic Stop with No Operation

If no operation is performed while both pots are working, after the display time ends, both heating and motor functions will stop, and the screen will display "OFF". After 5 prompt sounds of "beep", the appliance turns off and returns to standby mode.

4.6 Sync Finish Mode

4.6.1 Activating Sync Finish Mode

- This mode is activated when two menus with different times are set for the left and right pots. The Sync Finish Key indicator lights up, and the screen flashes.

4.6.2 Using Sync Finish Key

- Touch the Sync Finish Key to turn it on. Then, touch the Power Key to start the appliance. The pot with the longer time continues working, while the screen of the shorter time pot displays "HOLD".

- When the extra time has elapsed, the shorter timer will begin to work. The Sync Finish Key will remain on throughout this process.

4.6.3 Adjusting Time During Sync

- If the time set for one pot (displayed as "HOLD") is longer than the other, the sync finish mode will exit, and the SSync Finish Key indicator will turn off.

4.6.4 Pot Removal During Sync

- If the pot is pulled out during sync, the timer will pause, and the screen will show "OPEN". Once the pot is reinserted, sync will continue.

4.6.5 Exiting Sync with One Pot Suspended

- If one pot is suspended while the other continues to work during sync, the sync finish mode will exit, and the Sync Finish Key indicator will turn off.

5. None Divider Mode

5.1 Cooking Large Food

- When cooking large food, do not use the divider.
- Select **1**, select the desired menu, then select **2** and the same menu. Press the Power Key to start. For details, see Double Pots Working Mode.

5.2 Baking Whole Chicken

- Avoid using the divider when baking a whole chicken.
- Choose any menu for both the left pot and right pot.
- Set the temperature to 200°C and the time to 45 minutes for both pots.
- Touch the Power Key to turn on the heaters for both pots simultaneously and start baking.

1. Memory Function

- The appliance has a memory function that retains the last used settings.
- After cooking, if the appliance is not powered off, the next time you use it, it will display the menu used previously for the selected pot.

If the appliance is powered off for more than 1 hour, the memory is cleared, and the initial state will be displayed when the appliance is powered on again.

2. Power Off Memory

- Accidental Power Cut: If the appliance is in use and experiences an accidental power cut, it will retain its working state if power is restored within 30 minutes.
- Restoration: Upon re-energizing, the appliance will resume operation from the state it was in before the power was cut off.

3. Error Prompts

3.1 Error Code E1:

Description: The NTC (Negative Temperature Coefficient) sensor is open.

3.2 Error Code E2:

Description: The NTC sensor is short-circuited.

Cooking Tips

This table below will help you select the basic settings for your ingredients.

Note: These settings are indicative. Since ingredients vary in origin, size, shape, and brand, we cannot guarantee the optimal settings for all your ingredients.

Due to rapid air technology, which instantly reheats the air inside the appliance, briefly pulling the pot out during hot air frying barely disturbs the cooking process.

Tips:

- Smaller ingredients usually require a slightly shorter preparation time than larger ones.
- A larger amount of ingredients only requires a slightly longer preparation time, while a smaller amount requires a slightly shorter preparation time.
- Shaking smaller ingredients halfway through the preparation time optimizes the end result and helps prevent uneven frying.
- Add some oil to fresh potatoes for a crispier result. Fry your ingredients in the Hot-air fryer within a few minutes after adding the oil.
- Snacks that can be prepared in an oven can also be prepared in the Hot-air fryer.
- The optimal amount for preparing crispy fries is 500 grams.
- Use pre-made dough for quick and easy preparation of filled snacks; it also requires a shorter preparation time than homemade dough.
- Place a baking tin or oven dish in the Hot-air fryer basket if you want to bake a cake or quiche, or if you need to fry fragile or filled ingredients.
- You can also use the Hot-air fryer to reheat ingredients. To reheat, set the temperature to 150°C for up to 10 minutes.

Cooking Tips

Menu	Reference Weight	Default Temperature	Default Pot time	Temperature Range	Time Frame	Shake
DIY	300	230°C	10 min	40-230°C	1-60 min	1-2
Steak	400	200°C	15 min	80-200°C	1-60 min	1-2
Chicken leg	600	200°C	30 min	80-200°C	1-60 min	1-2
Fish	500	180°C	25 min	80-200°C	1-60 min	1-2
Pizza	400	180°C	10 min	80-200°C	1-60 min	--
Fries	450	200°C	25 min	80-200°C	1-60 min	1-2
Cake	400	180°C	12 min	80-200°C	1-60 min	--
Vegetables	300	170°C	20 min	80-200°C	1-60 min	1-2

Note 1: Add 3 minutes to the preparation time if you start frying while the hot-air fryer is still cold.

Note 2: When using two cooking pots simultaneously, you can adjust the temperature or time based on the actual cooking results.

Clean the appliance after every use.

Do not use metal kitchen utensils or abrasive cleaning materials, as these may damage the non-stick coating.

1. Remove the mains plug from the wall socket and let the appliance cool down.

Note: Remove the pot to help the Hot-air fryer cool down more quickly.

2. Wipe the outside of the appliance with a moist cloth.

3. Clean the pot and shelf with hot water, some washing-up liquid and a non-abrasive sponge.

You can use degreasing liquid to remove any remaining dirt.

Tip: If dirt is stuck to the shelf or the bottom of the pot, fill the pot with hot water with some washing-up liquid. Place the shelf in the pot and let both soak for approximately 10 minutes.

4. Clean the inside of the appliance with hot water and non-abrasive sponge.

5. Clean the heating element with a cleaning brush to remove any food residues.

Storage

1. Unplug the appliance and let it cool down.

2. Make sure all parts are clean and dry.

Troubleshooting

Problem	Possible Cause	Solution
The hot-air fryer does not work.	The appliance is not plugged in.	Put the mains plug in an earthed wall socket.
	You have not set the timer.	Set the timer key to the required preparation time to switch on the appliance.
The hot-air fryer does not work.	The amount of ingredients in the pot is too big.	Put smaller batches of ingredients in the pot. Smaller batches are fried more evenly.
	The set temperature is too low.	Set the temperature key to the required temperature setting (see section "Cooking Tips").
	The preparation time is too short.	Set the timer to the required preparation time (see section "Cooking Tips").
The ingredients are fried unevenly in the air fryer.	Certain types of ingredients need to be shaken halfway through the preparation time.	Ingredients that lie on top of or across each other (e.g. fries) need to be shaken halfway through the preparation time. (see section "Cooking Tips").
Fried snacks are not crispy when they come out of the air fryer.	You used a type of snacks meant to be prepared in a traditional deep fryer.	Use oven snacks or lightly brush some oil onto the snacks for a crispier result.
I cannot slide the pan into the appliance properly.	There are too much ingredients in the pot.	Do not fill the pot with too much ingredients.
	The pot is not placed in the appliance correctly.	Push the pot down into the appliance until you hear a click.
White smoke comes out of the appliance.	You are preparing greasy ingredients.	When you fry greasy ingredients in the air fryer, a large amount of oil will leak into the pot. The oil produces white smoke and the pot may heat up more than usual. This does not affect the appliance or the end result.

EN Troubleshooting

	The pot still contains grease residues from previous use.	White smoke is caused by grease heating up in the pan Make sure you clean the pan properly after each use.
Fresh fries are fried unevenly in the air fryer.	You did not use the right potato type.	Use fresh potatoes and make sure they stay firm during frying.
	You did not rinse the potato sticks properly before you fried them.	Rinse the potato sticks properly to remove starch from the outside of the sticks.
Fresh fries are not crispy when they come out of the air fryer.	The crispiness of the fries depends on the amount of oil and water in the fries.	Make sure you dry the potato sticks properly before you add the oil.
		Cut the potato sticks smaller for a crispier result.
		Add slightly more oil for a crispier result.

Specifications

Model	AF-5518ATB	Voltage	220-240 V~ 50-60Hz
Adjustable temperature	40 °C-230 °C	Rated Power	2700 W
Timer	1-60 mins	Left Basket Capacity	4.5 L
Right Basket Capacity	4.5 L		