

ES: Para resolver cualquier duda, visita: [support.spc.es](http://support.spc.es)

EN: To resolve any queries, visit: [support.spc.es](http://support.spc.es)

PT: Para resolver qualquer dúvida, visite: [support.spc.es](http://support.spc.es)

FR: Pour résoudre tout doute, visitez: [support.spc.es](http://support.spc.es)

DE: Um Fragen zu beantworten, besuchen Sie: [support.spc.es](http://support.spc.es)

IT: Per risolvere qualsiasi dubbio, visita: [support.spc.es](http://support.spc.es)



Copyright © 2024. Smart Products Connection S.A. All rights reserved.  
SPC is a registered trademark of Smart Products Connection S.A.  
[spc.es](http://spc.es)

SPC 14/01/1

## LLAMADAS DE TELÉFONO

Chamadas de telefone / Phone calls  
Appels téléphoniques



## HACER UNA LLAMADA

Fazer uma chamada / Make a call / Passer un appel

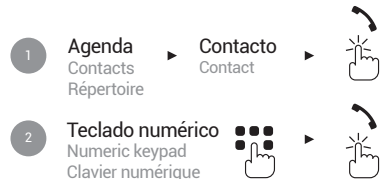

## AJUSTE DE VOLUMEN EN CONVERSACIÓN

Ajuste de volume em conversação  
Volume setting during a call  
Réglage du volume pendant un appel



## LINTERNA

Lantern / Torch / Lampe de poche



El teléfono debe estar encendido  
O telefone deve estar ligado  
The mobile phone must be on  
Le téléphone doit être allumé

## QUITAR EL PROTECTOR DE PANTALLA

Retirar o protetor de ecrã / Remove the screen protector  
Retirez le protecteur d'écran



# TALK 2

QUICK GUIDE

## CONTROLES BÁSICOS

Controles básicos / Main functions  
Commandes de base

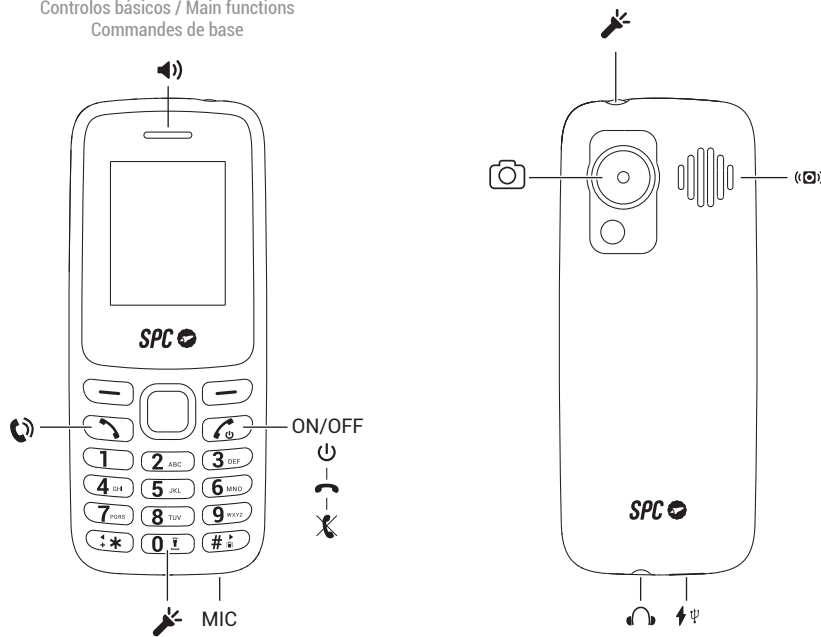

## PRIMEROS PASOS

Primeiros passos / First steps / Premiers pas

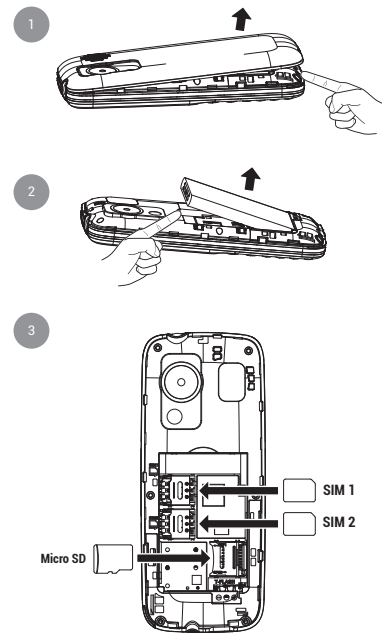

## ENCENDER-APAGAR

Ligar-Desligar / ON-OFF / Allumer- Éteindre

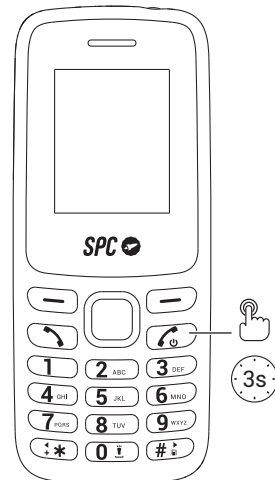

Pulsación corta  
Premir uma vez  
Single click  
Pression brève

Mantener pulsado  
Manter premido  
Long press  
Maintenir la touche  
enfoncée

## MÉTODO DE CARGA

Método de carregamento / Charge method  
Méthode de charge

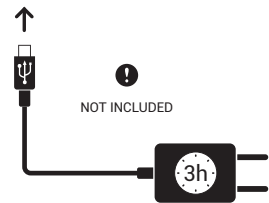

**EN** Para **cumplir** con la normativa vigente, **ahorrar** en residuos electrónicos y **proteger** al planeta, desde SPC hemos decidido dejar de incluir **adaptadores** en nuestros dispositivos.

Súmate a la causa y **reutiliza** uno que ya tengas por casa. Si esto no es posible, escríbenos a **support@spc.es**. Te ayudaremos a solucionarlo.

**EN** To **comply** with current regulations, **save** on electronic waste and **protect** the planet, at SPC we have decided to stop including **adapters** in our devices.

Join the cause and **reuse** one you already have at home. If this is not possible, write to us at **support@spc.es**. We'll help you sort it out.

**PT** Para **cumprir** a regulamentação em vigor, **poupar** nos resíduos eletrónicos e **proteger** o planeta, na SPC decidimos deixar de incluir **adaptadores** nos nossos aparelhos.

Junte-se a esta causa e **reutilize** um que já tenha em casa. Se isso não for possível, escreva-nos para **support@spc.es**. Nós ajudamo-lo a resolver o problema.

**FR** Afin de se **conformer** aux réglementations en vigueur, de **réduire** les déchets électroniques et de **protéger** la planète, SPC a décidé de ne plus inclure **d'adaptateurs** dans ses appareils.

Rejoignez la cause et **réutilisez** celui que vous avez déjà chez vous. Si ce n'est pas possible, écrivez-nous à **support@spc.es**. Nous vous aiderons à résoudre le problème.

**DE** Um die geltenden Vorschriften **einzuhalten**, Elektronikschrott zu **sparen** und den Planeten zu **schützen**, haben wir bei SPC beschlossen, unseren Geräten keine **Adapter** mehr beizulegen.

Machen Sie mit **und verwenden** Sie einen, den Sie bereits zu Hause haben. Wenn das nicht möglich ist, schreiben Sie uns an **support@spc.es**. Wir werden Ihnen helfen, das Problem zu lösen.

**IT** Per **risparmiare** le normative vigenti, **risparmiare** sui rifiuti elettronici e **proteggere** il pianeta, noi di SPC abbiamo deciso di non includere più gli **adattatori** nei nostri dispositivi.

Unitevi alla causa e **riutilizzate** quello che avete già a casa. Se ciò non fosse possibile, scrivete ci a **support@spc.es**. Vi aiuteremo a risolvere il problema.