

STS-42103N

TV FLOOR STAND
SOPORTE TV DE SUELO
SUPPORT TV DE SOL
SUPORTE TV DE CHÃO
TV-STANDFUß
STAFFA TV DA TERRA

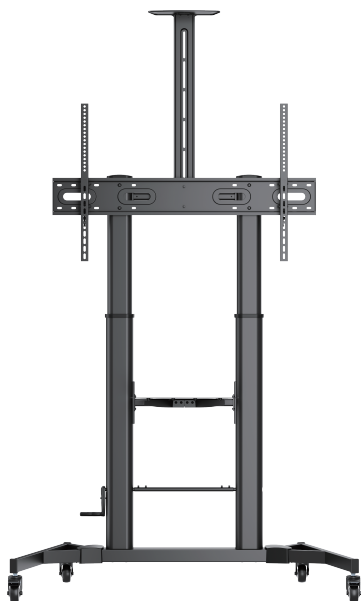

INSTRUCTION MANUAL/MANUAL DE USUARIO
MODE D'EMPLOI/MANUAL DE INSTRUÇÕES
BEDIENUNGSANLEITUNG/MANUALE D'ISTRUZIONI

FONESTAR

IMPORTANT/IMPORTANTE/IMPORTANT/IMPORTANTE/WICHTIG/IMPORTANTE

EN

- 1.- Follow the installation recommendations in the instruction manual.
- 2.- To ensure that the mount holds the maximum weight, the installation surface must be completely flat and firm; make use of wheel locking elements whenever possible.
- 3.- **FONESTAR** does not hold itself responsible for damages or breakages resulting from the mount falling apart because it was incorrectly attached, or handled incorrectly.

ES

- 1.- Siga las recomendaciones de instalación del manual de instrucciones.
- 2.- Para asegurar que el soporte aguante el peso máximo, la superficie de instalación debe ser totalmente plana y firme, siempre haciendo uso de los elementos de bloqueo de ruedas si dispone de ellas.
- 3.- **FONESTAR** no se hace en ningún caso responsable de las averías o roturas que pudieran derivarse de la caída del soporte al suelo por fallos del sistema de sujeción o por incorrecta manipulación.

FR

- 1.- Suivez les recommandations d'installation du mode d'emploi.
- 2.- Pour s'assurer que le support résiste au poids maximum, la superficie d'installation doit être totalement plate et ferme, utilisant toujours les éléments de blocage des roues, si vous disposez de celles-ci.
- 3.- **FONESTAR** dans aucun cas ne sera responsable des dégâts ou des cassures qui pourrait se produire dû au glissement du support du plafond par faille du même, du système de fixation ou produit par une manipulation incorrecte.

PT

- 1.- Siga as recomendações de instalação do manual de instruções.
- 2.- De forma a garantir que o suporte aguenta o peso máximo, a superfície de instalação deve ser totalmente plana e firme, recorrendo sempre aos elementos de bloqueio de rodas, caso os tenha.
- 3.- A **FONESTAR** não assume qualquer responsabilidade em caso de avarias ou quebras resultantes da queda do suporte ao chão por falhas do sistema de fixação ou por uma utilização incorreta.

DE

- 1.- Folgen Sie den Anweisungen in der Bedienungsanleitung.
- 2.- Um sich zu vergewissern, dass die Halterung das maximale Gewicht halten kann, muss die Oberfläche für die Installation vollkommen eben und fest sein. Falls Räder benutzt werden, müssen diese (wenn möglich) blockiert werden.
- 3.- **FONESTAR** übernimmt keine Haftung für Schäden oder Brüche, die durch das Herabfallen der Halterung auf den Boden, die auf Fehler im Befestigungs-system, oder auf unsachgemäße Handhabung zurückzuführen sind.

IT

- 1.- Seguire le raccomandazioni di installazione nel manuale di istruzioni per l'uso.
- 2.- Per garantire che la staffa rimanga al sicuro e sostenga il peso massimo, la superficie di installazione deve essere completamente piana e solida. Fare sempre uso degli elementi di bloccaggio delle ruote quando disponibile.
- 3.- **FONESTAR** non si ritiene responsabile, in nessun caso, dei danni o guasti che possano insorgere a causa del distacco dal pavimento a seguito di una installazione scorretta, errori nel modo di fissaggio o manipolazione sbagliata.

**ACCESSORIES INCLUDED/ACCESORIOS INCLUIDOS/ACCESSOIRES INCLUS/
ACESSÓRIOS INCLUIDOS/ENTHALTENDE ZUBEHÖRTEILE/ACCESSORI INCLUSI**



(x1)
A



(x1)
B

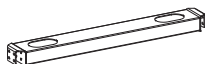

(x1)
C

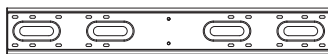

(x1)
D



(x2)
E



(x1)
F

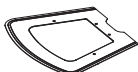

(x1)
G

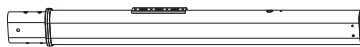

(x1)
H



(x1)
I



(x1)
J

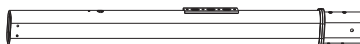

(x1)
K

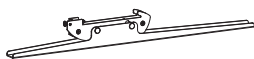

(x1)
L



(x1)
M



(x1)
N



(x1)
O

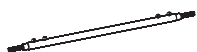

(x1)
P

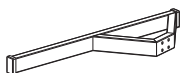

(x1)
Q

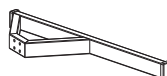

(x1)
R



(x2)
S



(x4)
T



M5x25 (x1)
U



M6x8 (x4)
V



M6x14 (x6)
W



M6x25 (x4)
X



M8x30 (x8)
Y



M8x40 (x8)
Z

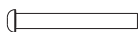

M8x65 (x4)
A1



M4x6 (x3)
B1



M4x6 (x2)
C1



D6 (x2)
D1



D8 (x4)
E1



5mm (x1)
F1



(x1)
G1



(x4)
H1



M5x14 (x4)
M-A



M6x14 (x4)
M-B



M6x30 (x4)
M-C



M8x30 (x4)
M-D



M8x50 (x4)
M-E



ø5-ø8 (x4)
M-F



ø15xø8x5 (x8)
M-G



ø15xø8x15 (x8)
M-H

ASSEMBLY INSTRUCTIONS/INSTRUCCIONES DE MONTAJE/INSTRUCTIONS POUR
LE MONTAGE/INSTRUÇÕES DE MONTAGEM/MONTAGEANLEITUNG/ISTRUZIONI
PER IL MONTAGGIO

1

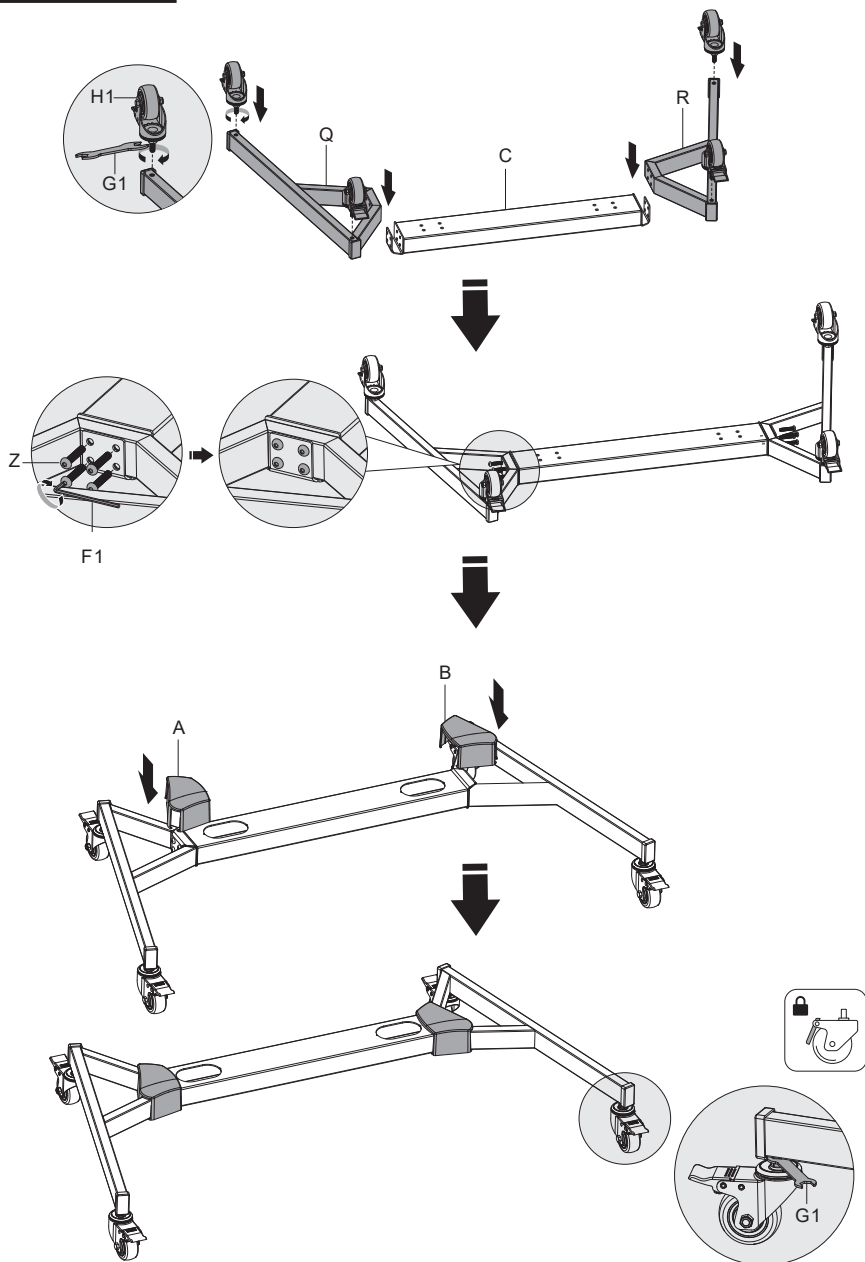

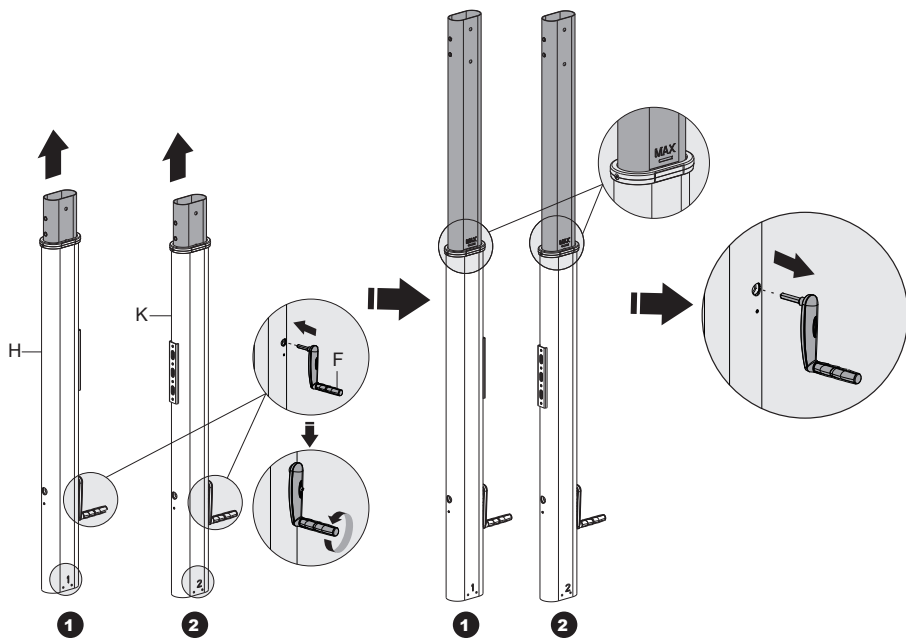

EN The inner rod must protrude by 40 mm. Fix its position by means of the 4 screws

ES La barra interior debe sobresalir 40 mm. Fije su posición mediante los 4 tornillos

FR La tige intérieure doit dépasser de 40 mm. Fixer sa position à l'aide des 4 vis

PT A haste interior deve sobresair 40 mm. Fixar a sua posição por meio dos 4 parafusos

DE Die innere Stange muss um 40 mm herausragen. Fixieren Sie seine Position mit den 4 Schrauben

IT L'asta interna deve sporgere di 40 mm. Fissare la posizione con le 4 viti

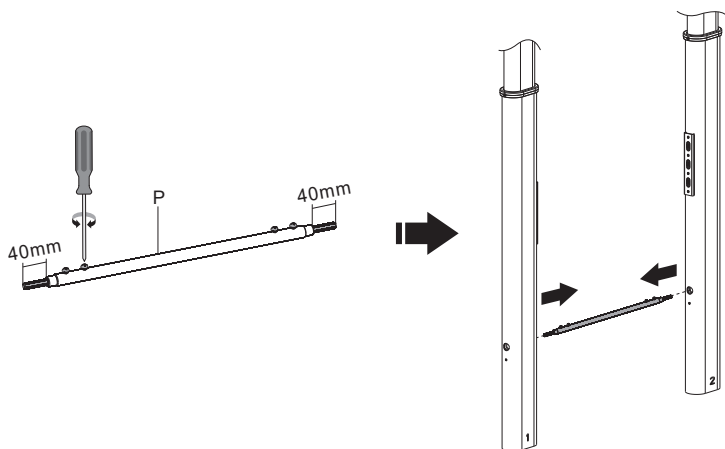

- EN** Place the structure on the base without tightening the screws firmly.
ES Coloque la estructura sobre la base sin apretar firmemente los tornillos.
FR Placer la structure sur la base sans serrer fermement les vis.
PT Colocar a estrutura sobre a base sem apertar bem os parafusos.
DE Setzen Sie die Struktur auf den Sockel, ohne die Schrauben fest anzuziehen.
IT Posizionare la struttura sulla base senza serrare a fondo le viti.

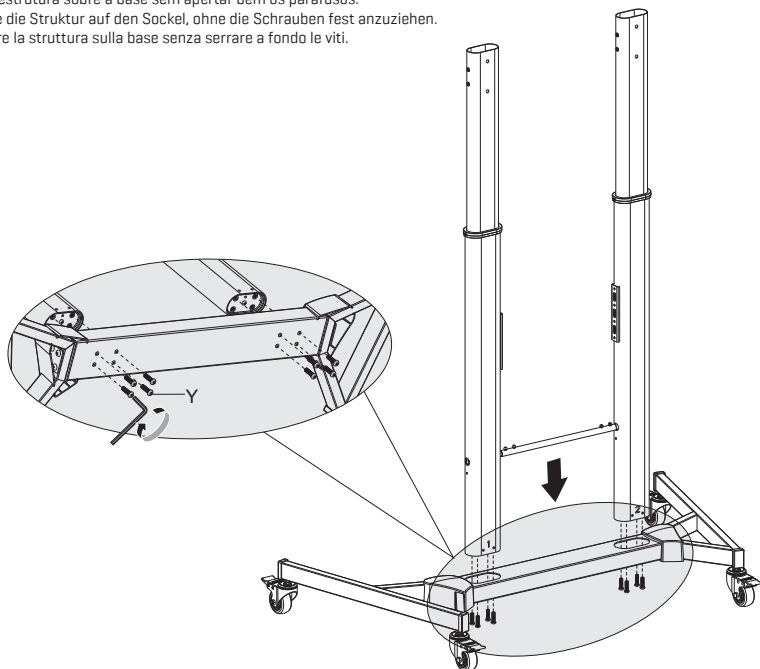

- EN** Tighten the base screws securely.
ES Apriete firmemente los tornillos de la base.
FR Serrer fermement les vis de la base.
PT Apertar bem os parafusos da base.
DE Ziehen Sie die Bodenschrauben fest an.
IT Serrare saldamente le viti della base.

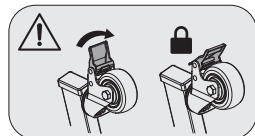
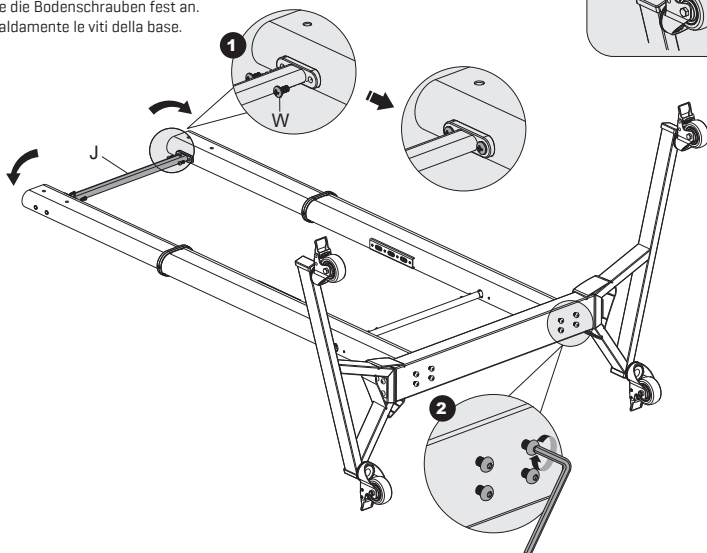

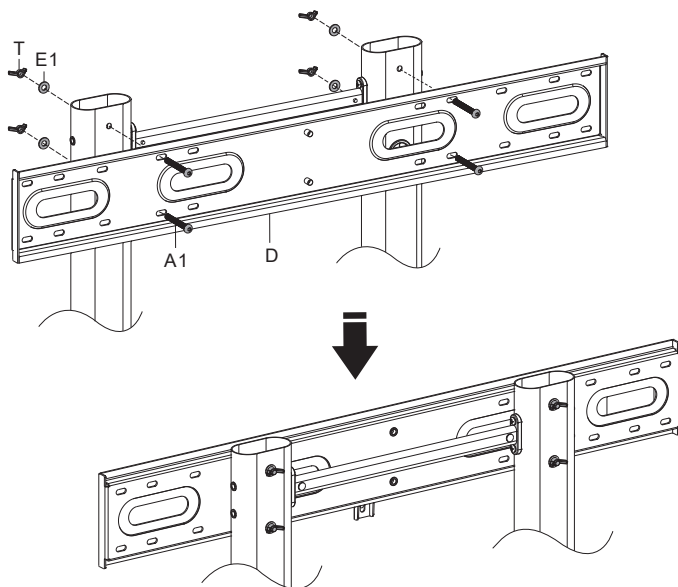

- EN** Adjust the height of the bracket and fix the position with the screw U.
ES Regule la altura del soporte y fije la posición con el tornillo U.
FR Régler la hauteur du support et fixer la position à l'aide de la vis U.
PT Ajustar a altura do suporte e fixar a posição com o parafuso U.
DE Stellen Sie die Höhe der Halterung ein und fixieren Sie die Position mit der Schraube U.
IT Regolare l'altezza della staffa e fissarne la posizione con la vite U.

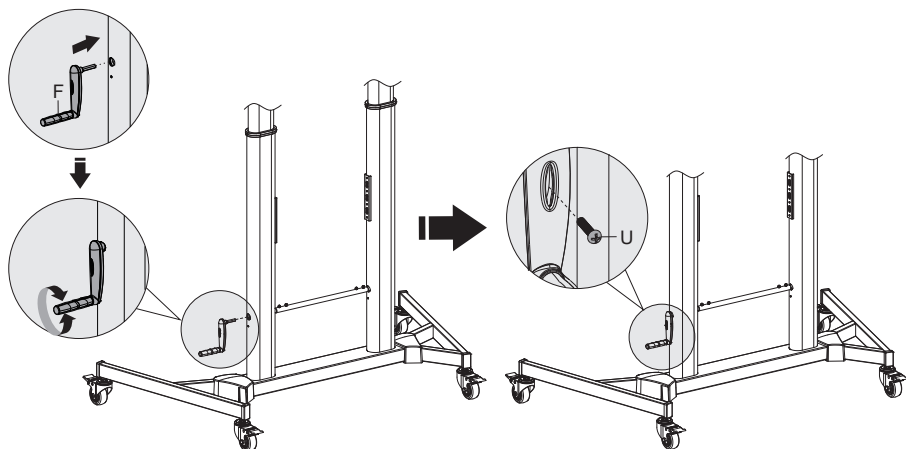

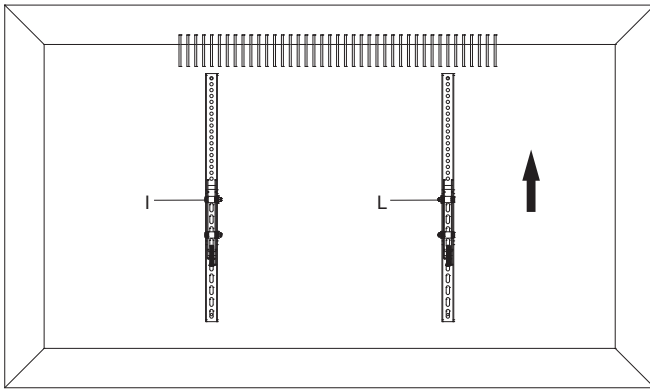

8a

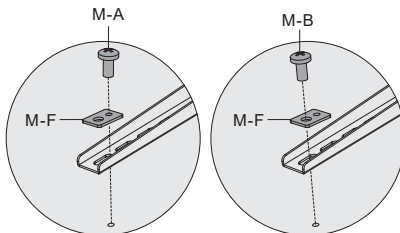
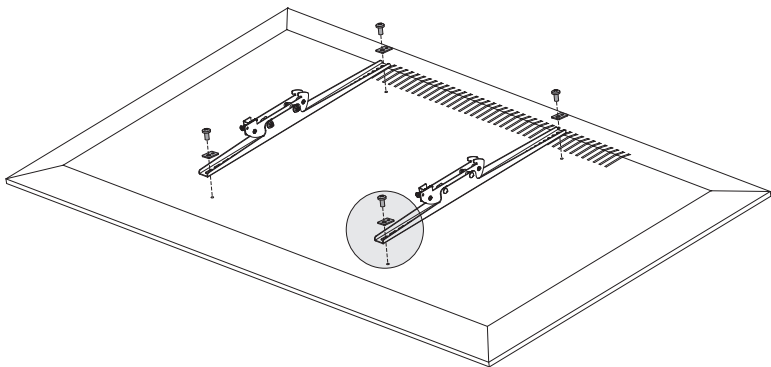
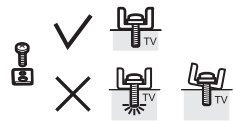



CURVE TV

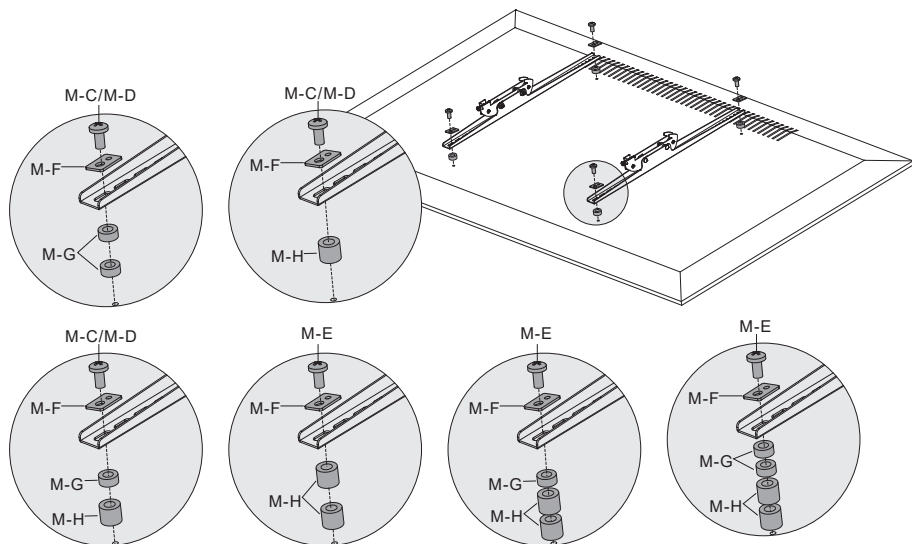
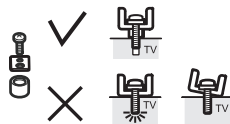

9

EN Place the TV on the horizontal plate and secure the position with the screws at the bottom.

ES Coloque la TV sobre el la placa horizontal y asegure la posición con los tornillos de la parte inferior.

FR Placez le téléviseur sur la plaque horizontale et fixez la position à l'aide des vis situées en bas.

PT Colocar o televisor na placa horizontal e fixar a posição com os parafusos na parte inferior.

DE Stellen Sie das Fernsehgerät auf die horizontale Platte und sichern Sie die Position mit den Schrauben an der Unterseite.

IT Collocare il televisore sulla piastra orizzontale e fissare la posizione con le viti in basso.

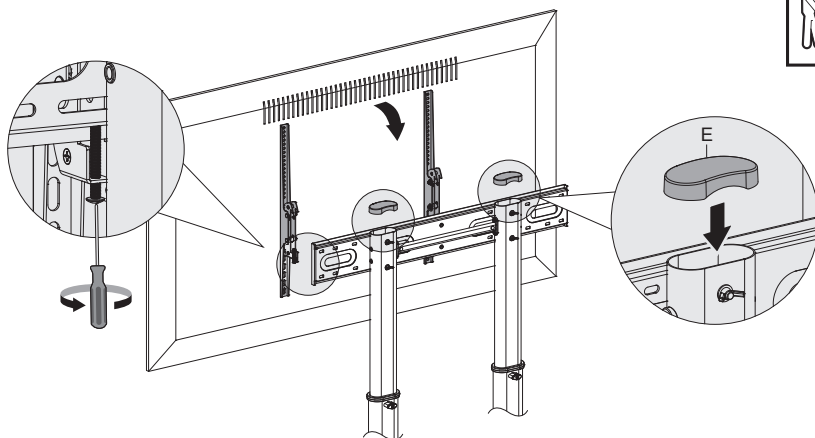

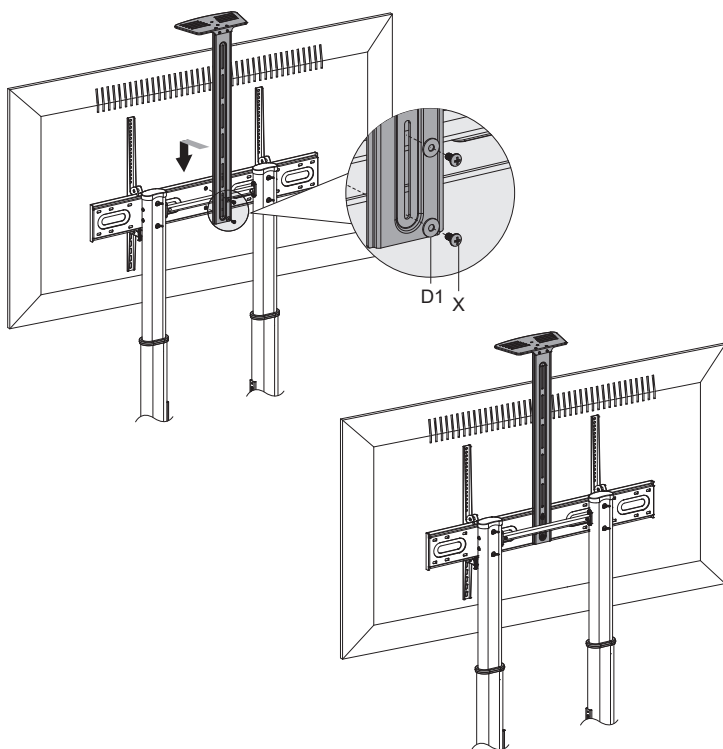
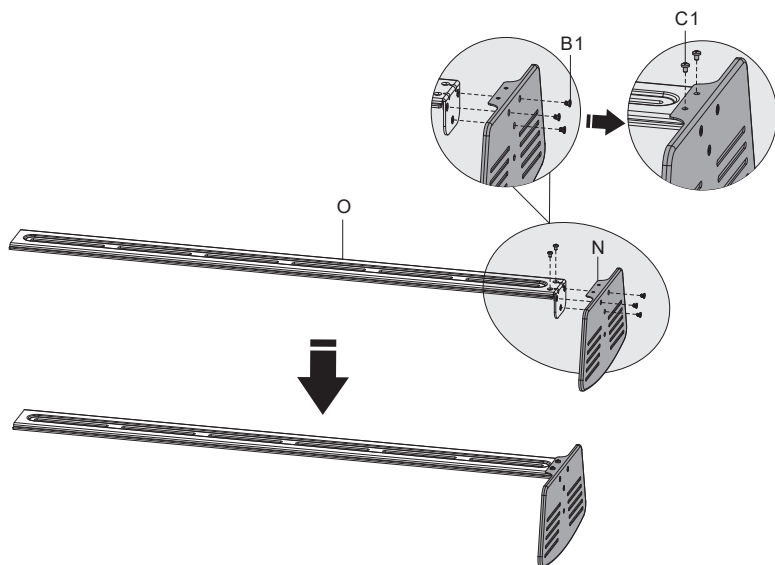

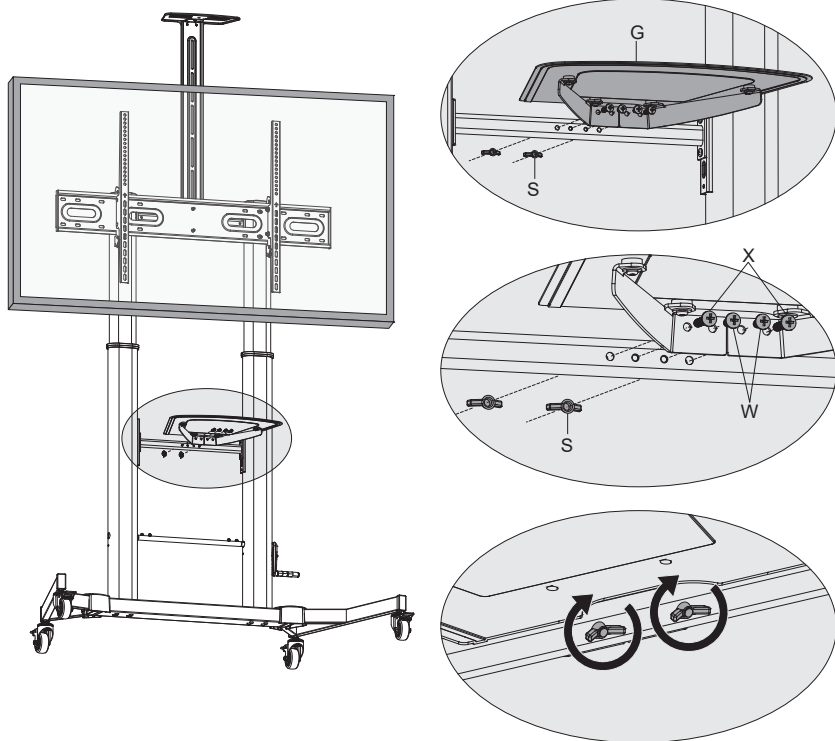
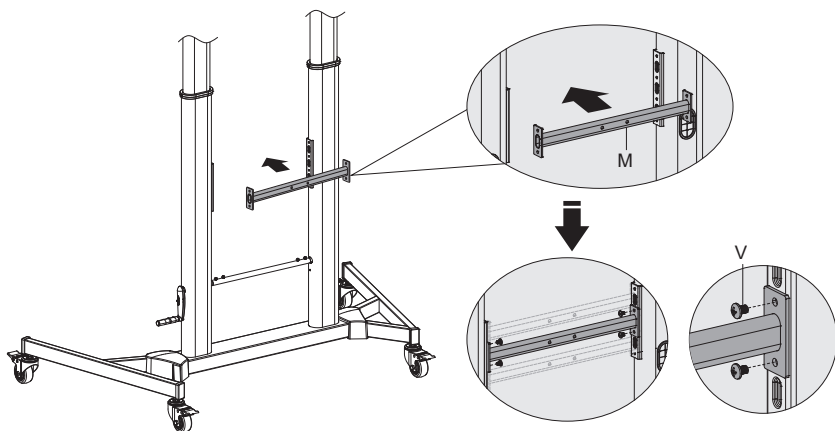

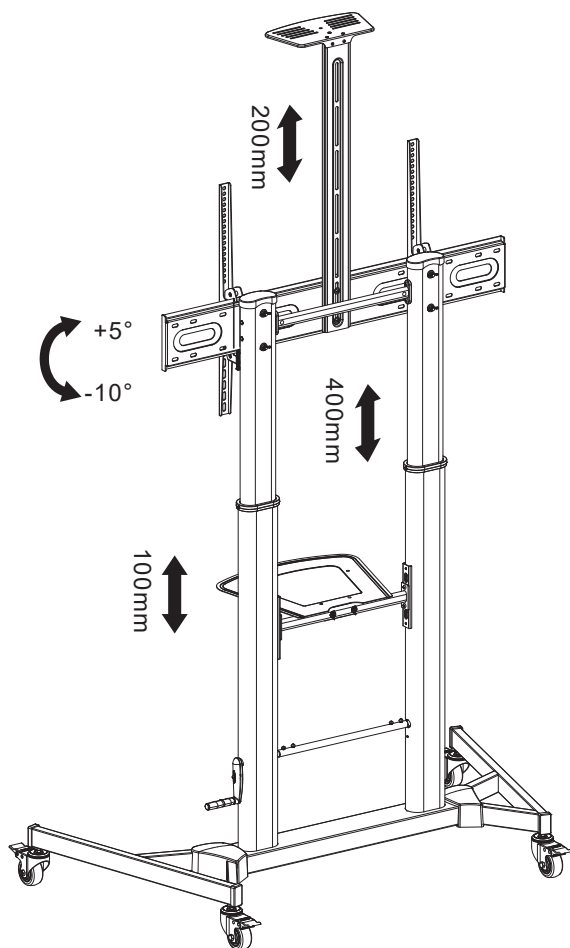

IMPORTANT/IMPORTANTE/IMPORTANT/IMPORTANTE/WICHTIG/IMPORTANTE

EN It is not recommended to adjust the height of the bracket with the TV installed.

It is recommended to regularly check the TV's attachment to the bracket.

ES No se recomienda ajustar la altura del soporte con la TV instalada.

Se recomienda revisar regularmente la fijación de la TV al soporte.

FR Il n'est pas recommandé de régler la hauteur du support lorsque le téléviseur est installé.

Il est recommandé de vérifier régulièrement la fixation du téléviseur sur le support.

PT Não é recomendado ajustar a altura do suporte com o televisor instalado.

Recomenda-se que verifique regularmente a fixação do televisor ao suporte.

DE Es wird nicht empfohlen, die Höhe der Halterung bei installiertem Fernsehgerät zu verstellen.

Es wird empfohlen, die Befestigung des Fernsehers an der Halterung regelmäßig zu überprüfen.

IT Non è consigliabile regolare l'altezza della staffa con il televisore installato.

Si raccomanda di controllare regolarmente il fissaggio del televisore alla staffa.